

Matrix® ELITE BACK

MODELS: PBE (STANDARD), PBE-HD (HEAVY-DUTY), EDB (DEEP), EDB-HD (DEEP-HD)
PBE-TR (TILT/RECLINE), PBE-TRHD (TILT/RECLINE HEAVY-DUTY)



USER MANUAL

DEALER: This manual MUST be given to the user of the product.

USER: Before using this product, read this manual and save for future reference.

en *This manual may not be reproduced or reprinted either partly or completely without previous written consent from Motion Concepts or its statutory representatives.*

This user manual is compiled from the latest specifications and product information available at the time of publication. We reserve the right to make any necessary as they become necessary. Any changes made to our products may cause slight variations between the illustrations and explanations in this manual and the product you have purchased. If you have any questions or concerns regarding the information provided in this manual, please contact our Customer Service Department for assistance.

1.0 GENERAL WARNINGS/INFORMATION

1.1 OVERVIEW

SAFETY SYMBOLS:

Proper set-up and safe use of your Matrix® Elite Back depends on your own good judgement and common sense, as well as that of your provider, caregiver and/or health professional. The following symbols are used throughout this user manual to identify warnings, cautions and important notes. It is very important that you read and understand them completely.

 **CAUTION!** Failure to heed the cautions in this manual may result in minor injury or damage to your Matrix Seating product, or both.

 **DANGER!** Indicates an imminently hazardous situation. Failure to heed the warnings in this manual may result in death or serious injury.

 **WARNING!** Indicates a potentially hazardous situation. Failure to heed the warnings in this manual may result in serious injury or damage.

 **IMPORTANT!** Important information to remember during installation, set-up and/or adjustment of you Matrix Seating product.

USER WARNING!

Improper use of this product may cause personal injury or damage. DO NOT use this product or any available optional equipment without first completely reading and understanding these instructions and any additional instructional material such as user manual, service manuals or instruction sheets supplied with this product or optional equipment. If you are unable to understand the warnings, cautions or instructions, contact a health care professional or dealer before attempting to use this equipment.

IMPORTANT INFORMATION

The best way to avoid problems related to pressure injuries is to understand their causes and your role in a skin management program. Your therapist and physician should be consulted if you have questions regarding individual limitations and needs.

All back supports should be selected carefully. Working with your therapist and physician is the best way to assure that a cushion choice matches your individual needs. As the needs of the individual become more complex, the evaluation becomes more important.

 **IMPORTANT!** Please refer to the Wheelchair Owners/Operators Manual for additional safety information, warnings and cautions related to the operation of your wheelchair.

1.2 INTENDED USE

Our Matrix® Elite backs are designed to provide precise orientation within the wheelchair to ensure optimal postural support and positioning for a wide variety of wheelchair users. Matrix® Elite Backs are suitable for use on a wide range of wheelchairs.

The Matrix® Elite TR back is specially designed for use in manual or power tilt only or tilt/recline applications, and includes an extra layer of SuperSoft foam for improved immersion and comfort.

2.0 SAFETY INFORMATION

2.1 TRANSPORTATION WARNINGS!

⚠ WARNING! Risk of Death, Serious Injury or Damage

- Risk of severe injury when transporting the client within a wheelchair fitted with an **Matrx® Elite Back** in a motor vehicle.

TRANSPORTING THE CLIENT IN A MOTOR VEHICLE WITHIN A WHEELCHAIR FITTED WITH A MATRX BACK

The following guidelines should be made available to all parties responsible for the transportation of the client, such as schools and transport providers.

- Wherever practicable Motion Concepts recommends that the client is transferred out of the wheelchair into a vehicle seat using a lap and diagonal seat belt or an appropriate child safety seat.
- A **Matrx® Elite Deep Back (EDB1820)** fitted with a Motion Concepts PHRK headrest and standard Easy-Set attachment hardware has been dynamically tested and meet the requirements of ISO 16840-4:2009, Wheelchair Seating- Part 4: Seating Systems for Use in Motor Vehicles; and Section 20, ANSI/RESNA WC-4:2017, Wheelchair Seating Systems for Use in Motor Vehicles. A forward facing frontal impact test was performed using an ISO/RESNA Surrogate Wheelchair Frame (SWCF) and a Hybrid III Midsize-Adult Male Anthropomorphic Test Device (ATD). The SWCF was secured by a four-point, strap type wheelchair tie-down and the ATD was restrained by a surrogate three-point belt with a SWCF-Anchored Lap Belt.
- **Matrx® Elite Backs** used to transport a client should **only** be used in conjunction with wheelchairs that comply with the performance requirements of RESNA WC19 or ISO 7176-19.
- For safe transportation of a client within a wheelchair in a motor vehicle, refer to the user manuals of the wheelchair and tie-down and occupant restraint system (WTORS)-see additional information below.

BEFORE ENTERING THE VEHICLE CHECK THE FOLLOWING:

The **Matrx Back** must be securely fastened onto the wheelchair in accordance with Manufacturers instructions.

Posture Belts & Harnesses should remain fitted on the wheelchair during transportation. Posture belts/harnesses are designed to provide postural support only, they are NOT intended for safety during transportation.

A **Head Support** should be securely fitted and correctly adjusted close to the rear of the client's head during transportation, to reduce the risk of whiplash injuries.

WHEELCHAIR TIE-DOWN & OCCUPANT RESTRAINT SYSTEM (WTORS)

- **Wheelchair Tie-down:** The wheelchair must be securely tied down within the vehicle, in a forward facing position, in accordance with the wheelchair and tie-down manufacturers instructions.
- **Occupant Restraint :** A suitable occupant restraint system must also be fitted in accordance with the manufacturer's instructions. A minimum is a lap and diagonal belt (lap belts on their own are not suitable). Restraints that loop over the shoulder and anchor to the vehicle floor should be avoided where possible, as they can cause a heavy downward load through the client during an impact, the preferred type anchor above and behind the shoulder as with a car seat belt. The lap section of the belt should fit snugly over the pelvis of the client and should not be able to ride up to the abdominal area. The upper torso section of belt should be in contact with the client's chest and fit over the shoulder(s), while not cutting into the neck or slipping off the shoulder(s).

i IMPORTANT! If the wheelchair and Matrix® Elite Back is transported unoccupied, the wheelchair should be tied down with suitable equipment according to the manufacturer's instructions. If the equipment is dismantled for transportation, ensure that all parts are secured safely within the vehicle.

2.2 GENERAL SAFETY AND INSTALLATION WARNINGS!

i IMPORTANT! PRIOR to use inspect ALL parts for shipping damage. If damage is noted, DO NOT use. Contact your carrier or service provider for further assistance.

⚠ DANGER! Risk of Death, Serious Injury, or Damage

Lighted cigarettes dropped onto an upholstered seating system can cause a fire resulting in death, serious injury or damage. Wheelchair occupants are at particular risk of death or serious injury from these fires and resulting fumes because they may not have the ability to move away from the wheelchair.

- DO NOT smoke while using this wheelchair

⚠ WARNING! Risk of Serious Injury

When establishing the mounting position for the Matrix® Back, ensure the stability of the wheelchair is not compromised. Adjusting the forward and aft position and/or angle of the backrest will alter the user's center of gravity within the wheelchair. It may be necessary to reposition the front casters, rear wheels, back angle, tilt-in-space, recline position and/or seat depth before use.

⚠ WARNING! Risk of Serious Injury or Damage

- The procedures in this manual should be performed by a qualified technician
- The hardware provided is high strength and tested for durability. **Do Not substitute hardware.** Use only the original hardware supplied with your Matrix back
- Attaching hardware that is loosely secured could cause loss of stability resulting in serious injury or damage.
- After ANY adjustments, repair or service and before use, make sure that all attaching hardware is tightened securely.
- DO NOT install the Matrix® back assembly onto back canes with an outside diameter greater than 1" (25mm) or less than 3/4" (19mm). Otherwise, injury or damage may occur.
- Heavy-Duty Mounting Hardware (HDMH) must always be used in combination with all models of Matrix Elite Heavy-Duty backs.
- When the Matrix Elite Back is added to a TILT and/or RECLINING wheelchair, a RIGIDIZER BAR or CROSSBAR must be present to stabilize the back canes.
- For power seating applications, the Fixed Mounting Hardware must be used.

⚠ WARNING Risk of Injury

Skin condition should be checked very frequently after the installation of any new seating system. Working with your therapist, physician and service provider is the best way to assure that a seating choice meets your individual needs.

⚠ WARNING! Risk of Injury

Invacare® Matrix® products are specifically designed and manufactured for use in conjunction with Invacare® Matrix® accessories. Accessories designed by other manufacturers have not been tested by Motion Concepts and are not recommended.

3.0 MATRIX ELITE BACK INSTALLATION

i IMPORTANT! Installation and set-up of your Matrix® Elite Back MUST be performed by a Qualified Technician and/or Healthcare Provider.

Our Matrix® Elite backs are constructed with a removable polyurethane foam filled cushion cover affixed to a contoured metal back shell. Each Elite back model has been uniquely designed to provide exceptional comfort, support and positioning. All Matrix® Elite back models include an optional lumbar support pad that can be installed/inserted behind the polyurethane foam cushion to provide additional positioning and support.

The Matrix® Elite outer cover is made of a moisture resistant/breathable polyester mesh (Meshtex™) fabric. Regular cleaning and inspection of the outer cover is recommended. Refer to 4.0 - Care and Maintenance

MOUNTING HARDWARE:

The Elite Back comes standard with our removable EasySet Mounting Hardware (PBMH). Additional hardware options (Fixed Hardware (FSSH), Extended Range Hardware (ERMH) and Split Mounting Hardware (SMH)) are available at the time of order.

NOTE: Our Elite Back mounting hardware may be installed onto wheelchair back canes that are up to 1" (25mm) wider or 1" (25mm) narrower than the nominal back width.

CONFIGURED MODEL	DESCRIPTION	CONTOUR DEPTH	WEIGHT CAPACITY
STD	PBEwwhh	Elite Back	300 lb. (136 kg)
	EDBwwhh	Elite Deep Back	
	PBEwwhh-TR	Elite TR (Tilt/Recline) Back	
HD	PBEwwhh-HD	Heavy-Duty Elite Back	500 lb. (227 kg)
	EDBwwhh-HD	Heavy-Duty Elite Deep Back	
	PBEwwhh-TRHD	Heavy-Duty Elite TR (Tilt/Recline) Back	

(wwhh = width/height)

Back sizes will vary depending on the model of Elite Back. Please contact your Service Provider or Therapist to determine the appropriate back model/size for your individual needs.

4.0 CARE AND MAINTENANCE

Frequent visual inspection should be performed on all components, including upholstery, foam, hardware/fasteners and any plastic components.

4.1 INSPECTION AND MAINTENANCE

▲ WARNING! Risk of injury or damage

- DO NOT continue to use this product if problems or damage is discovered;
- Corrective maintenance can be performed at or arranged through your service provider

Weekly: Inspect **ALL** fasteners weekly to ensure that mechanical connections and attaching hardware are tightened securely.

Monthly: Perform a visual inspection of parts including hardware, brackets, upholstery materials, foam, and plastics for deformation, corrosion, breakage, wear or compression. Replace damaged/worn components if necessary.

4.2 CLEANING AND DISINFECTION:

⚠️ WARNING! Risk of damage

To avoid infectious exposure, inspect cushion thoroughly and properly clean and disinfect any materials soiled with blood or other bodily fluids.

⚠️ CAUTION! Risk of damage

- DO NOT use cleaning and disinfecting agents with abrasive, staining, or polymer-damaging properties such as phenols, alcohols, or bleaches. Chlorine solutions used even in low concentrations on a regular basis can diminish the life of the cover.
- Chosen cleaning agents and disinfectants must be compatible with one another in order to effectively protect the materials on which they are applied.
- Keep clear of open heat sources during cleaning.

GENERAL CLEANING:

Outer Cover

- The knitted fabric side of the Elite cover can be wiped with a damp absorbent towel, cloth, or paper towel. Remove all gross contamination from surface (i.e. food particles, urine, feces, blood). Spot-clean with mild soap and water.

Back Shell/Hardware:

- The back shell and hardware/components can be wiped clean with soap and water as necessary.

CLEANING AND DISINFECTION INSTRUCTIONS: (for **Protect Slipcover** (Optional))

For Matrix Elite backs fitted with our optional infection control **Protect Slipcover**, the coated side of the cover can be cleaned and disinfected with ready-to-use disinfecting wipes 3M, Virox Accel TB, Accel Prevention, PREempt, OPTIM 33 TB, or other wipes with similar formulations. Note that the surface should be cleaned first, with all gross contamination (i.e. urine, feces, blood) first removed with absorbent material (cloth or paper towel). Ensure the coated surface of the cover is clean by wiping with one of 2-in-1 cleaning and disinfecting wipes mentioned above.

To disinfect, liberally wipe the surface with the ready-to-use disinfecting wipe again. Avoid pooling of the disinfectant and ensure the disinfectant is distributed equally over the cover surface. Wipe dry after recommended dwell time (refer to each disinfecting products manufacturing instructions). It is best practice to wipe the surface with a damp cloth, mild soap, and finally a damp cloth no matter what disinfectant is used.

LAUNDERING THE OUTER COVER:

ⓘ IMPORTANT! The Elite outer cover **MUST** be removed from the inner foam cushion **PRIOR** to laundering. (**Note:** Do Not Dry Clean, Do Not Bleach).

ⓘ IMPORTANT! Adequate drying is a crucial factor in the care and maintenance of the covers. The covers should be dried completely prior to use on the cushion. Air drying of covers is recommended.

Machine Wash or Hand-Wash:

- Remove the Elite cushion cover by releasing the velcro hook & loop fasteners along the top, bottom and inside of the back shell.
- Carefully remove the Elite cover from the inner foam cushion.
- The Elite (Meshtex fabric) cover can be hand washed or machine-washed in warm water not higher than 60°C (140°F), on a delicate cycle. with neutral detergents such as Tide or Persil.
- To avoid possible damage, ensure the cover does not come in contact with any other sharp garment accessories during laundering.

Drying:

- DO NOT WRING OUT fabric. Hang to dry on a towel-covered wood hanger and drip dry to minimize wrinkling.
- Alternatively, covers may be tumble-dried on a low/cool setting. Cushion covers should not be ironed or pressed.

i Polyurethane (PU) coated fabrics can absorb liquids for short periods causing a temporary change to the PU characteristics. The wet cover is more vulnerable to physical damage and should not be used until fully dried.

4.3 REUSE/RECYCLING

This product is suitable for re-use. The outer cover (fabric and foam), back shell and mounting hardware must be fully inspected by a qualified dealer or healthcare professional before re-use.

⚠ WARNING! Risk of injury

- Always have an authorized dealer inspect the product for damage or wear PRIOR to transferring the product to a different user. If any damage is found, DO NOT RE-USE this product. Failure to heed these warnings may result in injury to the user.
- PRIOR to reuse, clean and disinfect the product thoroughly in accordance with local government regulations - see also Section 4.2, Cleaning and Disinfection Instructions.

4.4 DISPOSAL

The disposal and recycling of used devices and packaging must comply with the applicable local legal regulations.

Ensure that the cushion is cleaned prior to disposal to avoid any risk of contamination.

5.0 WARRANTY INFORMATION

WARRANTY

PLEASE NOTE: THE WARRANTY BELOW HAS BEEN DRAFTED TO COMPLY WITH FEDERAL LAW APPLICABLE TO PRODUCTS MANUFACTURED AFTER JULY 4, 1975.

This warranty is extended only to the original purchaser/user of our products. This warranty gives you specific legal rights and you may also have other legal rights which vary from state to state. Invacare/Motion Concepts warrants this product to be free from defects in materials and workmanship for two years of use by original purchaser. This warranty does not apply to punctures, tears or burns, nor to the removable cushion cover. If within such warranty period any such product shall be proven to be defective, such product shall be repaired or replaced, at Invacare's/Motion Concepts' option, with refurbished or new parts. This warranty does not include any labor or shipping charges incurred in replacement part installation or repair of any such product. Product repairs shall not extend this warranty-coverage for repaired product shall end when this limited warranty terminates. Invacare's/Motion Concepts' sole obligation and your exclusive remedy under this warranty shall be limited to such repair and/or replacement. For warranty service, please contact the dealer from whom you purchased your Invacare/Motion Concepts product. In the event you do not receive satisfactory warranty service, please write directly to Invacare/Motion Concepts at the address on the back cover. Provide dealer's name, address, model number, the date of purchase, indicate nature of the defect and, if the product is serialized, indicate the serial number.

Invacare Corporation/Motion Concepts will issue a return authorization. The defective unit or parts must be returned for warranty inspection using the serial number, when applicable, as identification within thirty (30) days of return authorization date.

DO NOT return products to our factory without our prior consent. C.O.D. shipments will be refused; please prepay shipping charges.

LIMITATIONS AND EXCLUSIONS: THE WARRANTY SHALL NOT APPLY TO PROBLEMS ARISING FROM NORMAL WEAR OR FAILURE TO ADHERE TO THE ENCLOSED INSTRUCTIONS. IN ADDITION, THE FOREGOING WARRANTY SHALL NOT APPLY TO SERIAL NUMBERED PRODUCTS IF THE SERIAL NUMBER HAS BEEN REMOVED OR DEFACED; PRODUCTS SUBJECTED TO NEGLIGENCE, ACCIDENT, IMPROPER OPERATION, MAINTENANCE OR STORAGE; OR PRODUCTS MODIFIED WITHOUT INVACARE'S/MOTION CONCEPTS' EXPRESS WRITTEN CONSENT INCLUDING, BUT NOT LIMITED TO: MODIFICATION THROUGH THE USE OF UNAUTHORIZED PARTS OR ATTACHMENTS: PRODUCTS DAMAGED BY REASON OF REPAIRS MADE TO ANY COMPONENT WITHOUT THE SPECIFIC CONSENT OF INVACARE/MOTION CONCEPTS; PRODUCTS DAMAGED BY CIRCUMSTANCES BEYOND INVACARE'S/MOTION CONCEPTS' CONTROL; PRODUCTS REPAIRED BY ANYONE OTHER THAN AN INVACARE/MOTION CONCEPTS DEALER, SUCH EVALUATION SHALL BE SOLELY DETERMINED BY INVACARE/MOTION CONCEPTS.

THE FOREGOING WARRANTY IS EXCLUSIVE AND IN LIEU OF ALL OTHER EXPRESS WARRANTIES, IF ANY, INCLUDING THE IMPLIED WARRANTIES OF MERCHANTABILITY AND FITNESS FOR A PARTICULAR PURPOSE. IT SHALL NOT EXTEND BEYOND THE DURATION OF THE EXPRESSED WARRANTY PROVIDED HEREIN AND THE REMEDY FOR VIOLATIONS OF ANY IMPLIED WARRANTY SHALL BE LIMITED TO REPAIR OR REPLACEMENT OF THE DEFECTIVE PRODUCT PURSUANT TO THE TERMS CONTAINED HEREIN. INVACARE/MOTION CONCEPTS SHALL NOT BE LIABLE FOR ANY CONSEQUENTIAL OR INCIDENTAL DAMAGES WHATSOEVER. THIS WARRANTY SHALL BE EXTENDED TO COMPLY WITH STATE/PROVINCIAL LAWS AND REQUIREMENTS.

6.0 ELITE BACK ACCESSORIES

6.1 HEAD SUPPORT INTERFACE PLATE (OPTIONAL)

All Matrix Elite backs contain a headrest adapter plate (A) which can be used for attaching an optional headrest support. Elite Headrest Adapter (EHRA) plates can differ slightly depending on the size and model of Elite back. The EHRA Plates are designed to be compatible with most standard headrest hardware (sold separately).

INSTALLING THE ELITE HEADREST ADAPTER (EHRA) PLATE

1. Release the hook and loop fasteners and remove the outer cover from the back shell
2. Align the EHRA plate (A) with the four pre-drilled mounting holes in the top center of the back shell.
3. Install using the Mounting Screws* x4 (B), Spacers x2 (C) (for Elite HD backs only) and Locknuts x4 (D), secure the headrest adapter plate to the Elite back.
*(*note: mounting screws should be installed from the inside of the back shell (as illustrated)).*
4. Ensure all hardware is securely tightened and reinstall the outer cover.

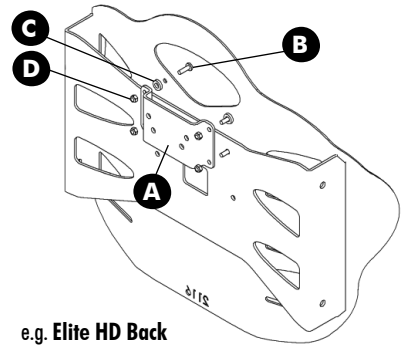
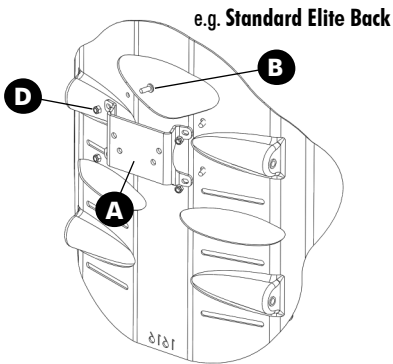

6.3 LUMBAR SUPPORT (OPTIONAL)

The Lumbar Support (A) is included with ALL Matrix Elite Backs. The Lumbar Support is a pre-fabricated foam insert that provides optional lower back support for improved positioning and comfort. (see *instructions/images below*).

INSTALLING THE LUMBAR SUPPORT:

1. Open the outer cover at the bottom rear of the back shell (via the hook and loop fastener).
2. Install the lumbar support inside the Elite back cover (behind the existing foam pad), as illustrated below.
3. Refasten the outer cover onto the back shell.

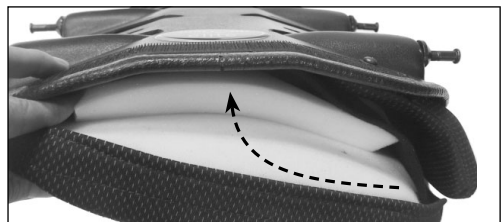
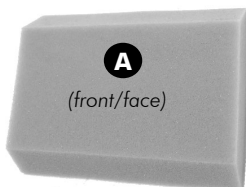

6.3 ONE-HAND CORD RELEASE MECHANISM

1. Thread the nylon cord through the holes in the latch mechanism at the top of the left and right mounting plates (**A**)
2. Install the cord lock mechanism onto the cord (**B**). Press the button to open the lock mechanism and slide the two open ends of the nylon cord through the opening.
3. With the back properly installed on the wheelchair, adjust the cord length so that it hangs at approximately a 35-45° angle along the back pan (**C**) (this allows the release mechanism to operate more effectively). If necessary, cut/remove excess cord to eliminate any risk of entanglement. Once adjusted, combine the loose cord ends into a single knot to prevent the cord-lock from slipping (**D**).

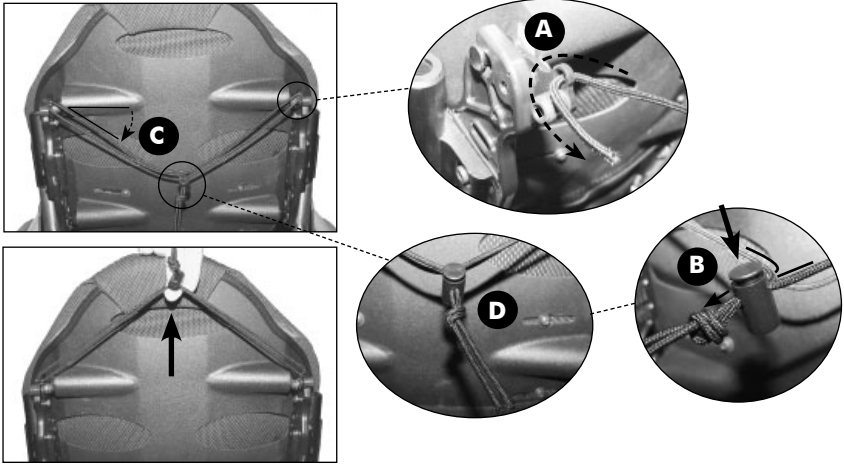



Motion Conceptswww.motionconcepts.com

USA

700 Ensminger Rd. Suite 112
Tonawanda, NY 14150
888-433-6818

Canada

505 Cityview Blvd, Unit 1
Vaughan, Ontario L4H 0L8
905-695-0134
866-748-7943



Copyright © 2024 Motion Concepts LP. All rights reserved. Republication, duplication or modification in whole or in part is prohibited without prior written permission from Motion Concepts. Trademarks are identified by ™ and ®. All trademarks are owned by or licensed to Invacare Corporation or its subsidiaries unless otherwise noted.

