

OWNER'S MANUAL

Model: F500S SIT-TO-STAND PATIENT LIFT



SPAN
better science. better care.

BEFORE USE:



Ensure the product has been assembled according to the instructions in this manual. All operators should read and understand the instructions for safe and proper operation of the patient lift.

P11584

Thank you for choosing Span

To better serve you, please record the following information for future use:

Supplier Name: _____

Supplier Telephone: _____

Product Serial Number: _____

Date of Purchase: _____

Date of Manufacture

The manufacture date can be found on the serial number. The YY on the serial number is the manufacture year, and the MM is the manufacture month.

INSPECT YOUR MERCHANDISE

Upon receipt of your lift, verify that it is complete and free from any shipping damage. Refuse delivery if the packaging appears to be badly damaged. If the merchandise is damaged or any component is missing, contact the shipping company immediately and file a claim. For further assistance, contact your local dealer or Span-America.

DEFINITIONS & SYMBOLS

In this manual the user refers to the patient or resident and may be used interchangeably at different times. Caregiver refers to the operator or person who is assisting with the transfer.

Symbols used in this manual and their meanings:



Warning! Failure to heed this warning may result in damage to the product or serious injury to the operator and/or user.



Important instructions follow. Read and understand the instructions in the manual before using the product.



Note! Important information concerning the product and/or its correct and proper usage follows.

Safety Instructions



The Span-America series of patient lifts reflect innovative state of the art design to increase user mobility. The product will provide years of service if it is properly maintained as any electric and/or mechanical equipment requires. Please pay careful attention to the following important information regarding the care, maintenance, and operation of the patient lift. Carefully read these instructions before assembling the lift, or attempting to lift a user with the device.

Please Note



- Special care must be taken with users/patients who cannot themselves provide assistance while being lifted. (i.e. patients who are comatose, spastic, agitated, or otherwise severely handicapped.)
- The patient lift should be used solely for transferring a user/patient from one utility (beds, chairs, toilets, etc.) to another. The patient lift should not be used for transporting or moving any patient from one location to another location.
- During lifting or lowering, whenever possible, always keep the base of the lift in the widest position.
- The base of the lift should be closed before moving the lift.
- Do not roll casters over any object while the user/patient is in the sling.
- Do not lock casters during lifting.
- While being lifted in a sling, always keep the user/patient centered over the base and facing the caregiver operating the lifter.
- Never leave the user/patient unattended during lifting.

The F500S can assist a person to be lifted and transferred safely, with minimum physical effort provided by the caregiver. Before attempting to lift anyone, please practice operating the lift. Also prior to actual lifting, explain the lifting procedure to the user/patient.

Service personnel may contact Span for any information, instructions or certain parts for servicing purpose.



Class II Equipment



WARNING!

- **NO** modification of this equipment is allowed. It is unsafe to modify the equipment from its original state. This product is deemed safe to use with only the original parts as delivered. Unauthorized use of any modified equipment may result in serious injury or death.
- **DO NOT** replace any components of the lift without consulting with Span, and follow proper instructions when replacing any components.
- **DO NOT** service any parts of the lift while in use with a patient.
- It is **NOT** safe to load the equipment more than the indicated maximum safe working load.
- **IF** any accessories with lower load capacity than the equipment itself is used, **DO NOT** load the equipment more than the lowest maximum safe working load.
- **REMOVE** the battery pack if the lift will not be used for some time, to prevent battery leakage. **Periodically** check the battery pack as well as the charger if necessary
- This equipment **DOES NOT** consist of any materials or ingredients to which patients are exposed, that may cause bodily harm or injury.
- Prolonged exposure or physical contact with any part of the equipment **will not** cause skin irritation, allergic reaction, etc.
- Using accessories, detachable parts, or materials not described in the instruction manual **MAY RESULT IN SERIOUS INJURIES.**
- Keep the equipment away from children and pets when in use. **IT MAY CAUSE SERIOUS INJURY OR DEATH.**
- Keep the equipment away from pests or pest infested area. Diseases transferred from pests to the equipment **MAY CAUSE SERIOUS ILLNESS** to patients upon contact.
- If the lift is left under the sun for long period of time, be **CAUTIOUS** as the surface of the lift may be hot.
- There are no risk if the lift is exposed to reasonably foreseeable environmental conditions
- **Caution!** The controller contains parts and assemblies that could be susceptible to **damage by electrostatic discharge (ESD)**. To reduce the likelihood of this from happening, one should be grounded prior to operate the controller.
- **DO NOT** use the lift on a inclined surface that that greater than 5°

FEATURES & OVERVIEW

i Prior to assembly, unpack all parts from the shipping carton and check for any missing parts. Contact your dealer immediately if a part is missing.

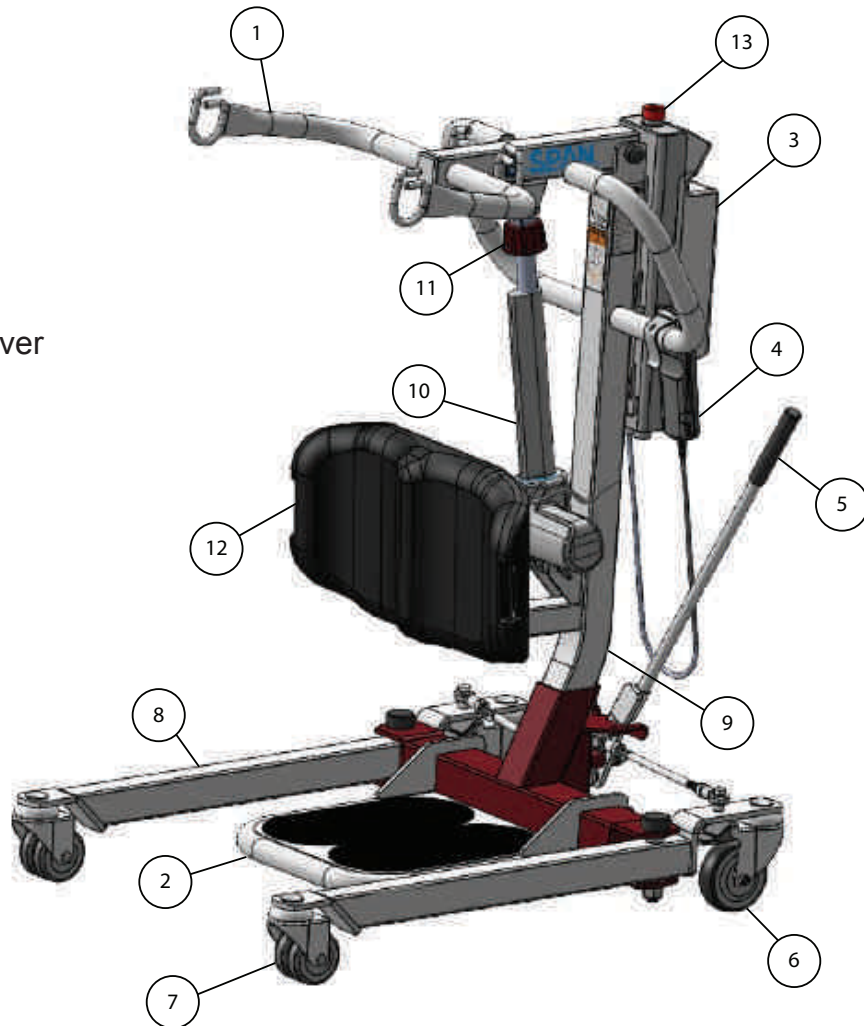
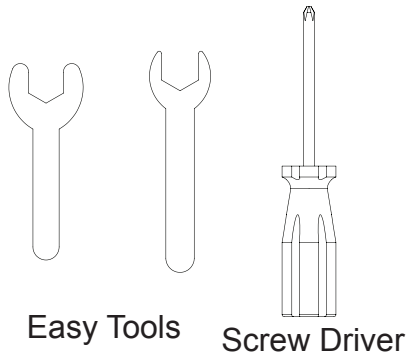

| | | | | | | | |
|---|-------------------|---------------------|----|--------------|----------------------|----|------------------------------|
| 1 | Boom | 8.4 lb (3.8 kg) | 6 | Rear Caster | | 11 | Emergency Lowering |
| 2 | Footplate | 10.1 lb (4.6 kg) | 7 | Front Caster | | 12 | Knee Pad 2 lb (0.9 kg) |
| 3 | Control Unit | 11 lb (5 kg) | 8 | **Base | 42.3 lb (19.3 kg) | 13 | Emergency Stop Button |
| 4 | Hand Control | 0.7 lb (0.3 kg) | 9 | Mast | 14.3 lb (6.5 kg) | | |
| 5 | Leg Opening Lever | 1.1 lb (0.5 kg) | 10 | Actuator | 7.3 lb (3.3 kg) | | |

** Heaviest detachable part

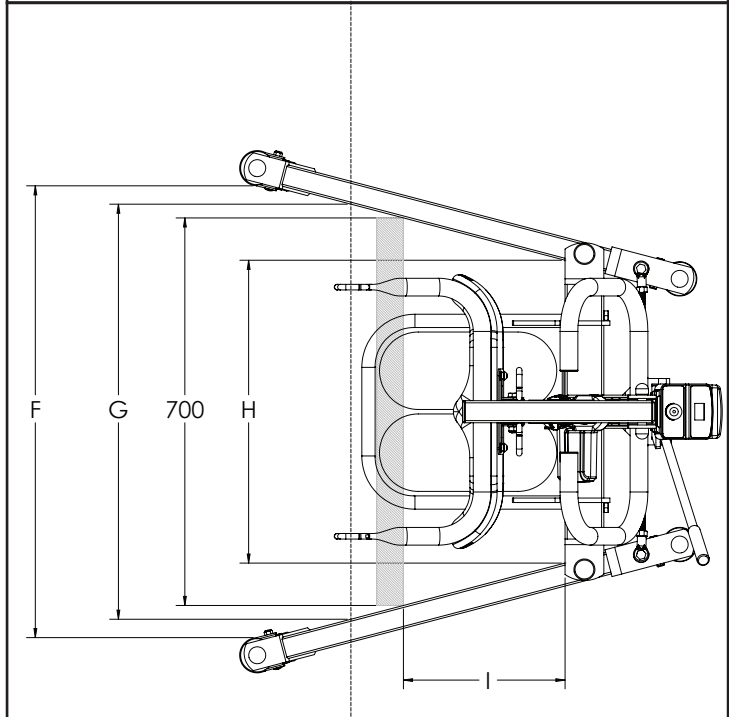
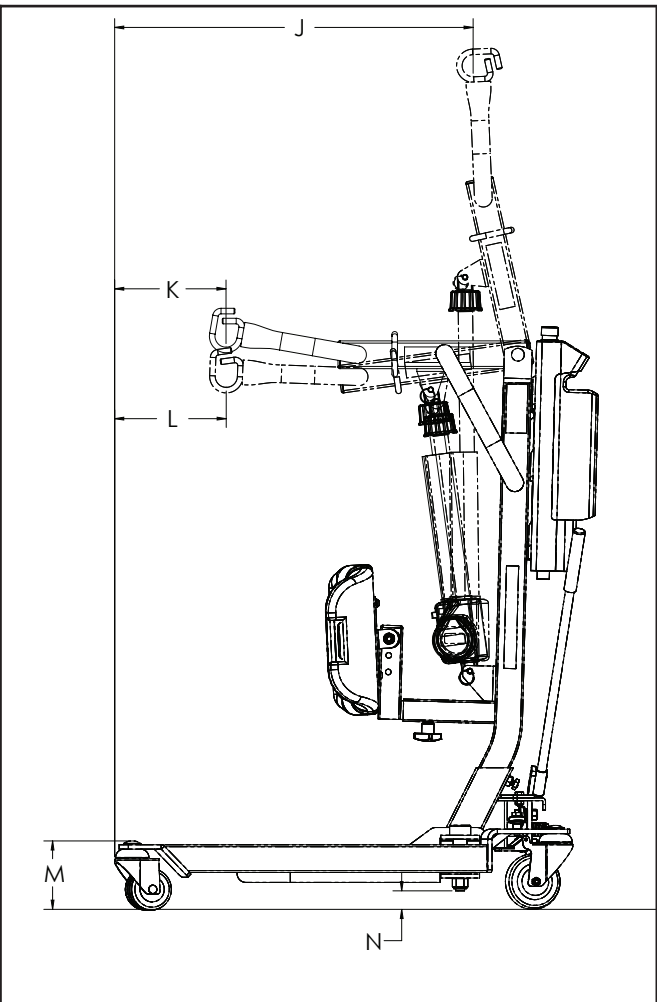
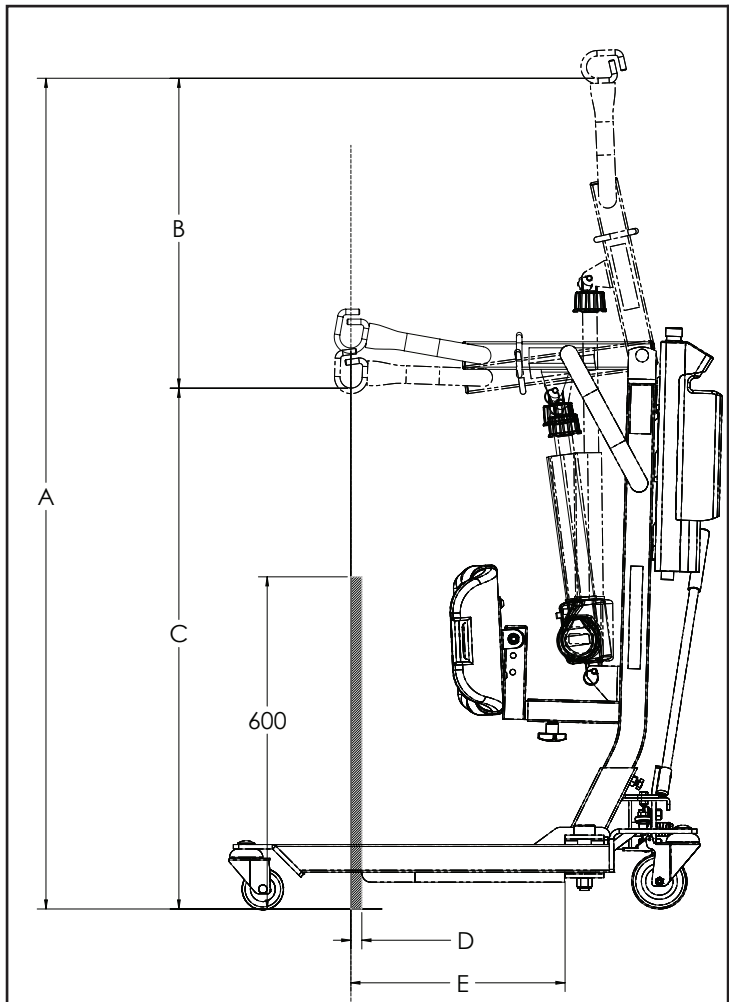

| | F500S mm (in) |
|---|------------------|
| A | 1500.5 (59.1) |
| B | 559.7 (22.0) |
| C | 940.7 (37.0) |
| D | 19.8 (0.8) |
| E | 386.8 (15.2) |
| F | 816.1 (32.1) |
| G | 749.8 (29.5) |
| H | 547 (21.5) |
| I | 291.9 (11.5) |
| J | 646.3 (25.4) |
| K | 200.8 (7.9) |
| L | 201.2 (7.9) |
| M | 123.4 (4.9) |
| N | 33.4 (1.3) |

SPECIFICATIONS & OPTIONS

| Specifications of Control Unit | |
|--------------------------------|--|
| Input Voltage | 220-240VAC 50Hz / 110-120VAC 60Hz |
| Output Voltage | 24 VDC |
| Battery Pack | 24 VDC 5AH |
| Lift Control | Handset and Panel |
| Protection Class | IP54 (Protection against dust and splash of water) |
| Sound Level Under Full Load | 16db |
| Sound Level Under No Load | 11db |
| Cycles Per Charge | 25 full cycles under full load |
| Overload Warning | by LCD |
| Battery Status | by LCD |
| Duty Cycle | 10% Duty cycle (Max 2 minute ON, 18 minute OFF) |

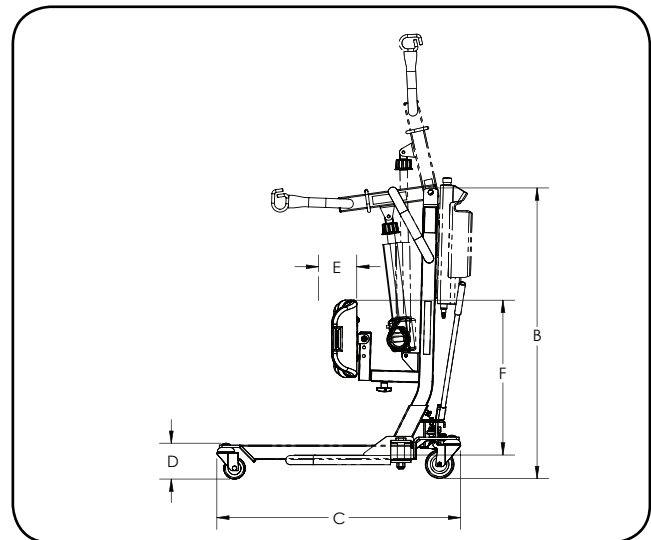
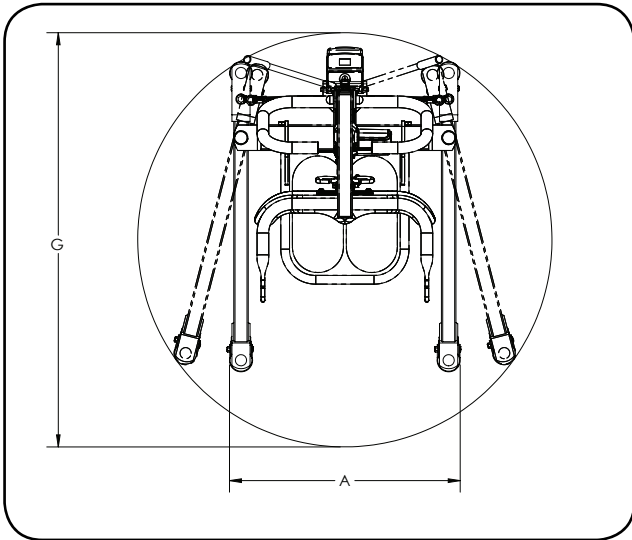

| Additional Dimensions & Specifications | | |
|--|--------------------------|-----------------|
| Model | | F500S |
| Safe Working Load | | 500 lb |
| A | Base Ext. Width - Closed | 24.9" |
| B | Mast Height | 40" |
| C | Base Length | 33.5" |
| D | Front Caster Height | 4.7" |
| E | Knee Pad Depth Range | 4" |
| F | Knee Pad Height Range | 21", 20" or 19" |
| G | Turning Diameter | 45" |

| Standard Features | |
|-------------------|-----------------------------------|
| 1 | 4-Points Boom |
| 2 | 4" Rear Caster with Brake |
| 3 | 3" Dual Front Caster |
| 4 | Power Control Unit |
| 5 | Single Piece Molded Kneepad |
| 6 | Depth Adjustable Kneepad Position |
| Optional Features | |
| 1 | Charging Cradle |
| 2 | Second Battery Pack |

| | F500S |
|---------------------------|-------|
| Lift Weight Unloaded (lb) | 107.1 |
| Lift Weight Unloaded (kg) | 48.7 |

* Span-America is committed to continuous improvements of our products therefore the specs, dimensions, and features listed above are for guidance only and subject to change without prior notice.

F500S

TC12 Control Box

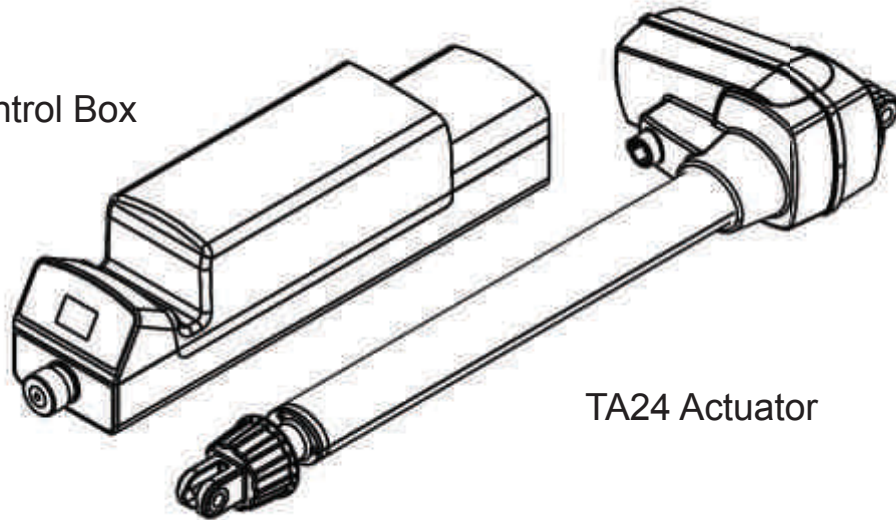

TA24 Actuator

Installation

Step 1: Base and Mast

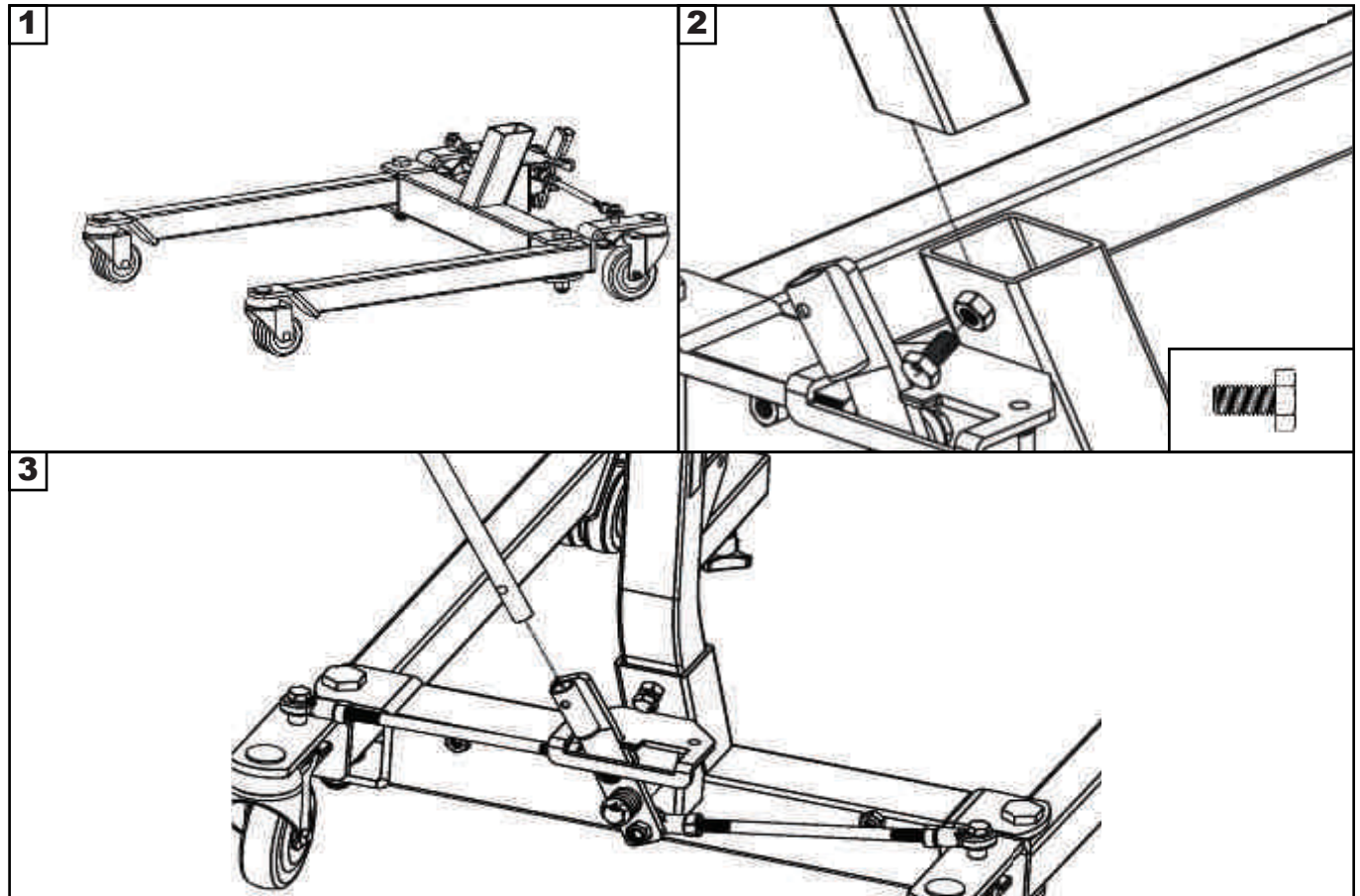

Step 2: Boom

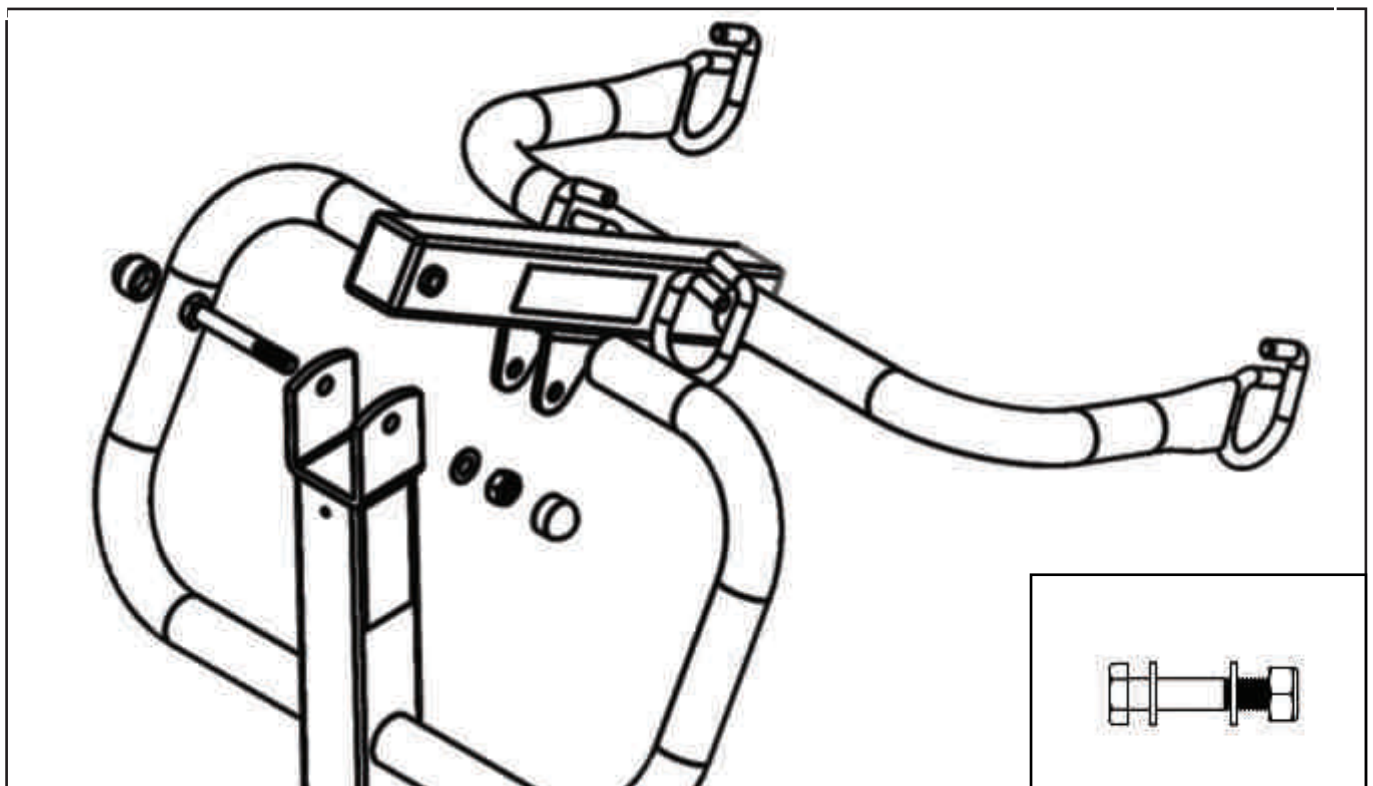

Step 3: Footplate

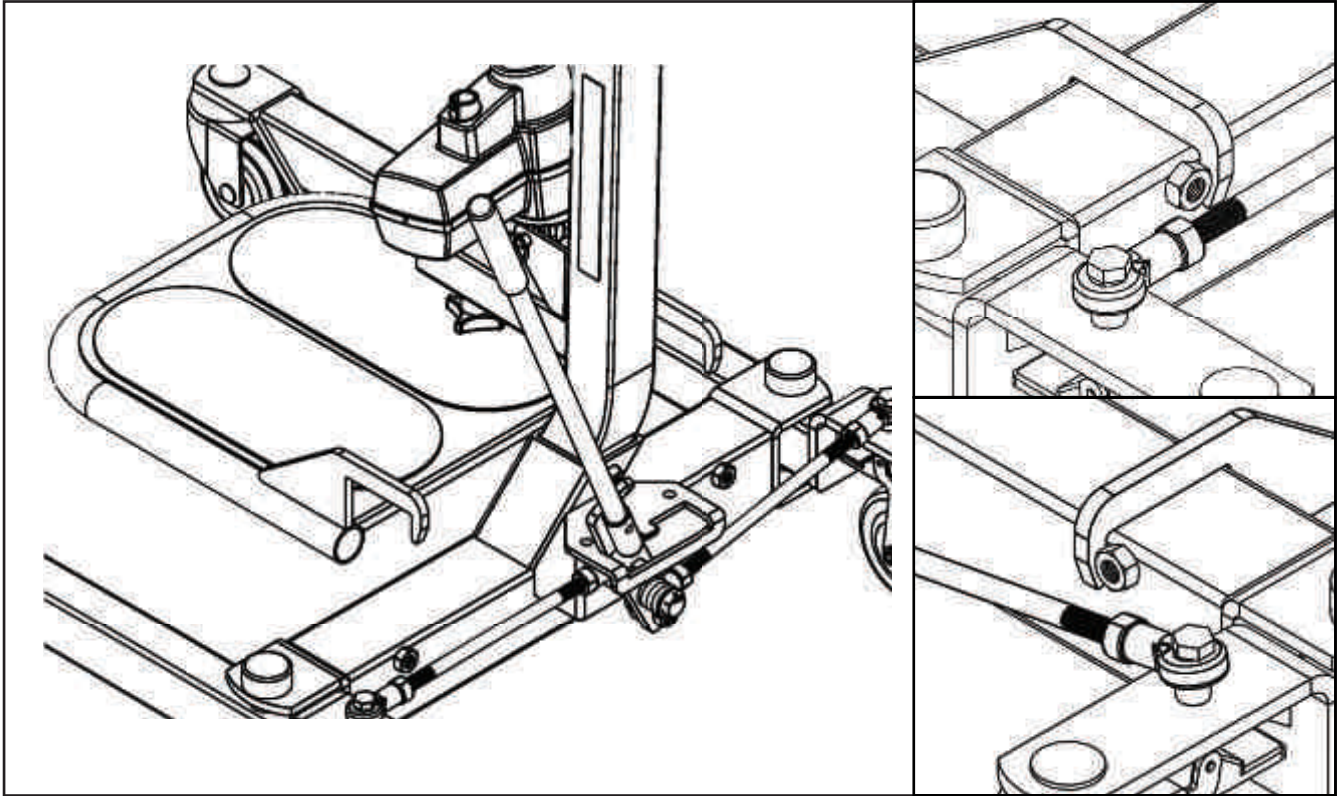

Step 4: Actuator

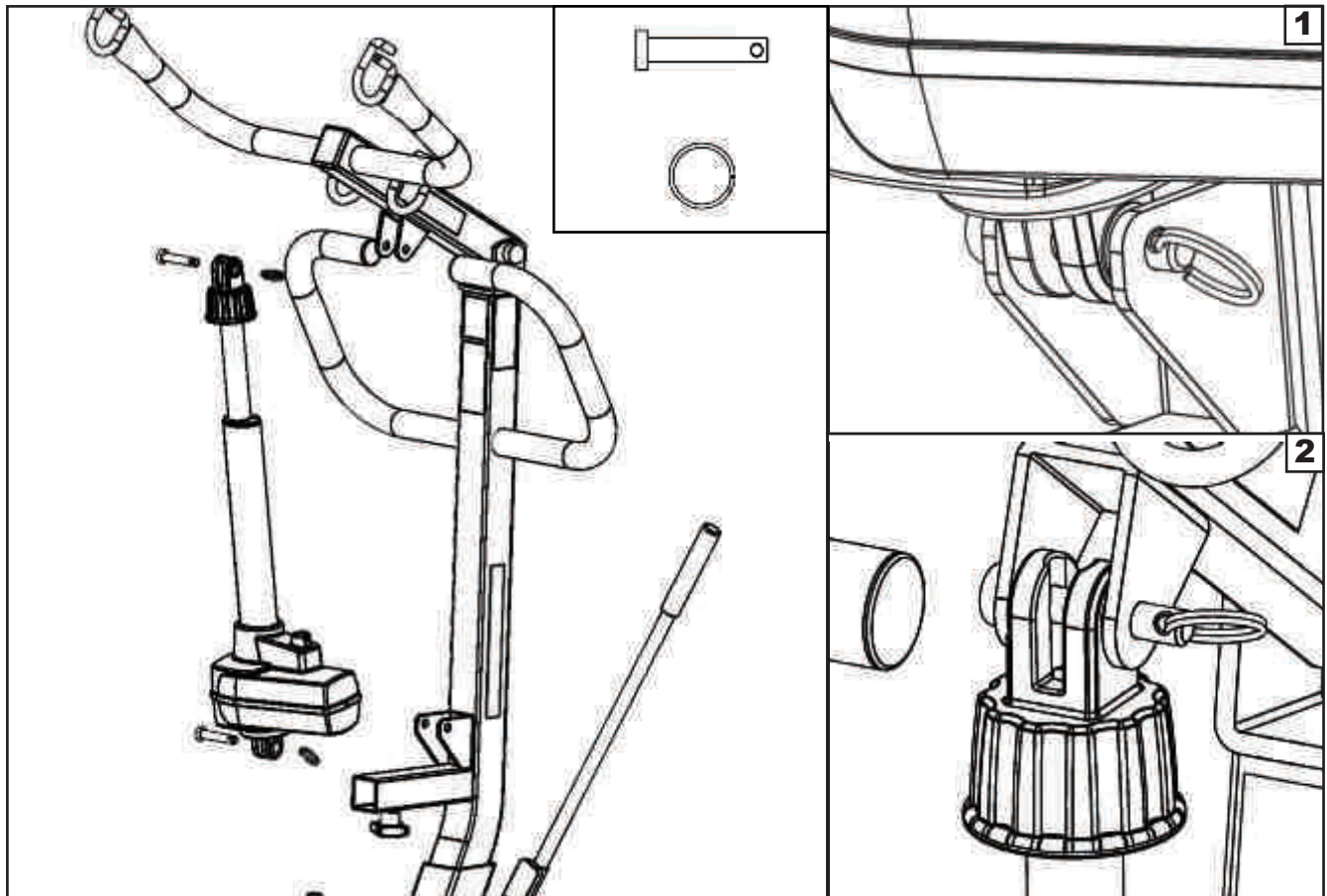

Step 5: Knee Pad

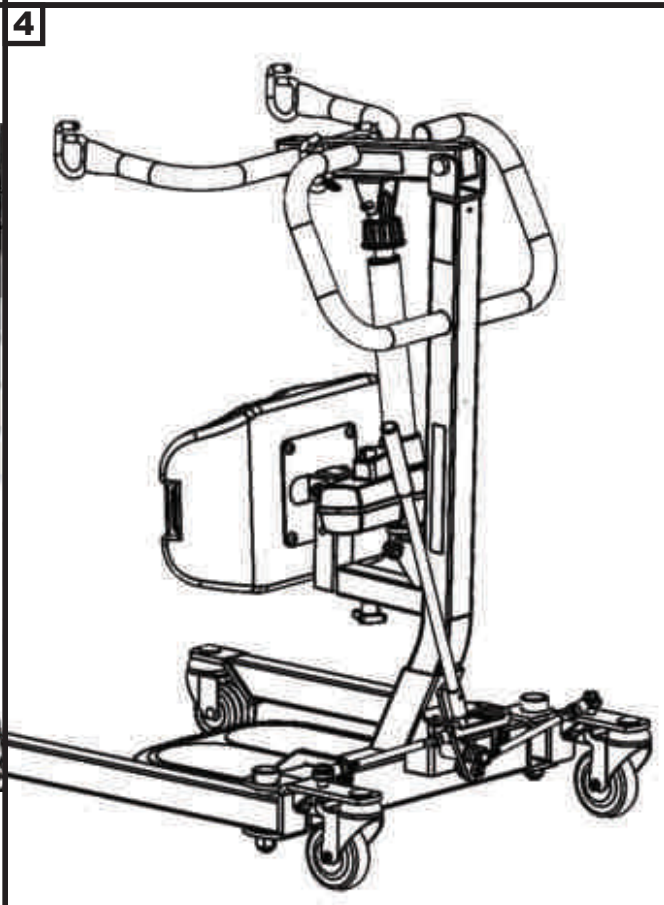
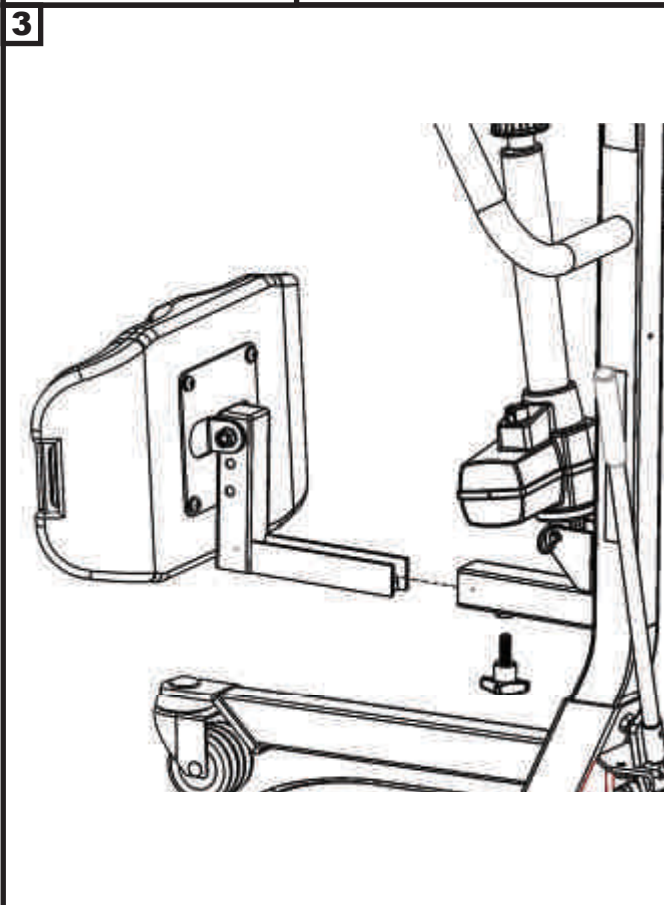
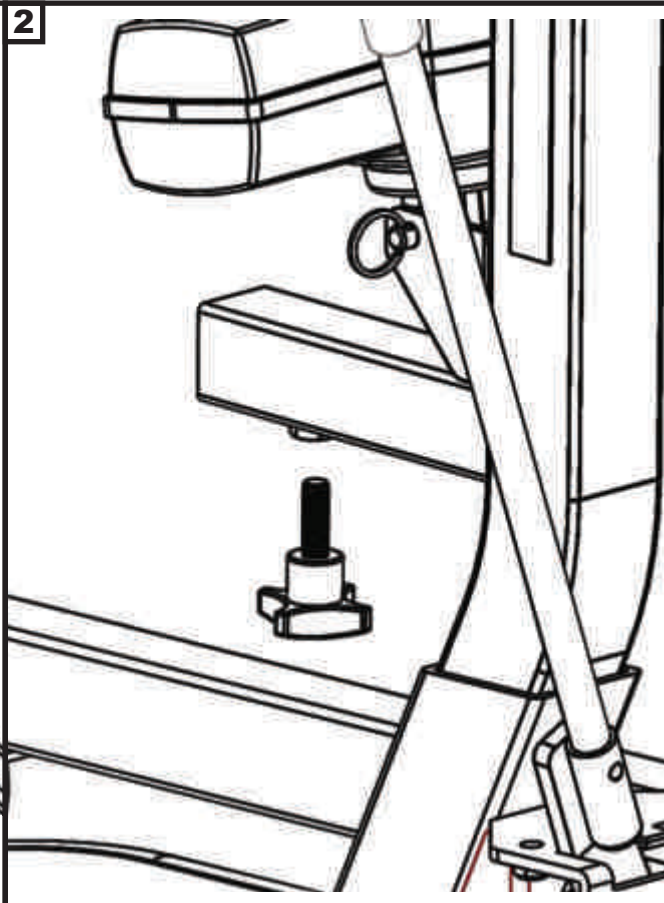
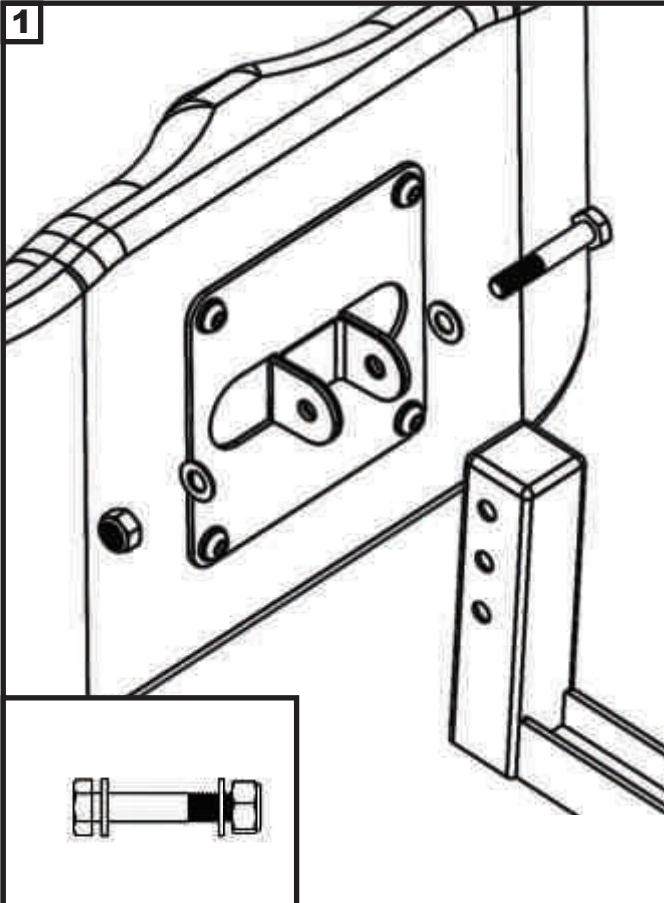

Step 6: Power Control Unit

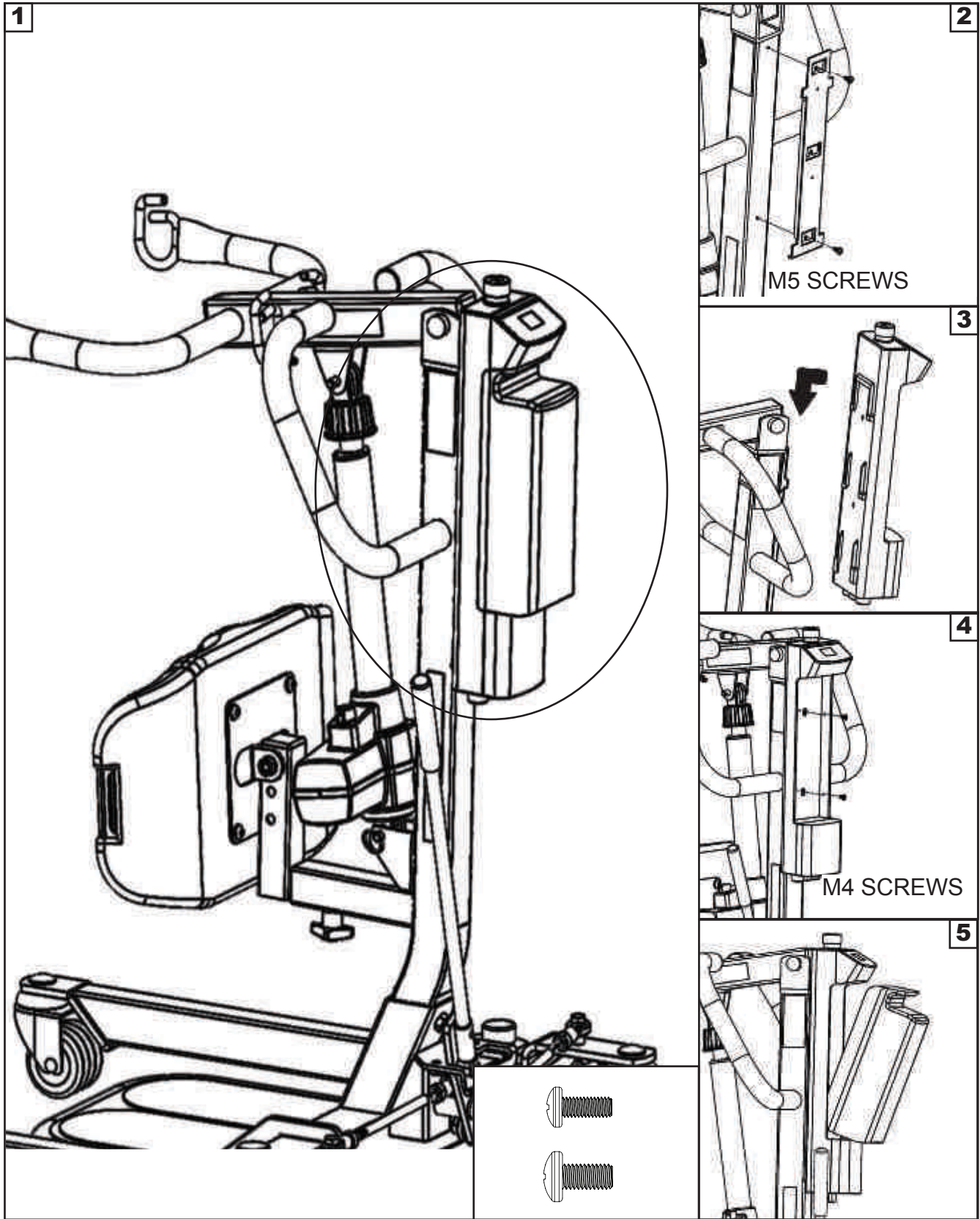

Power Control Unit Overview

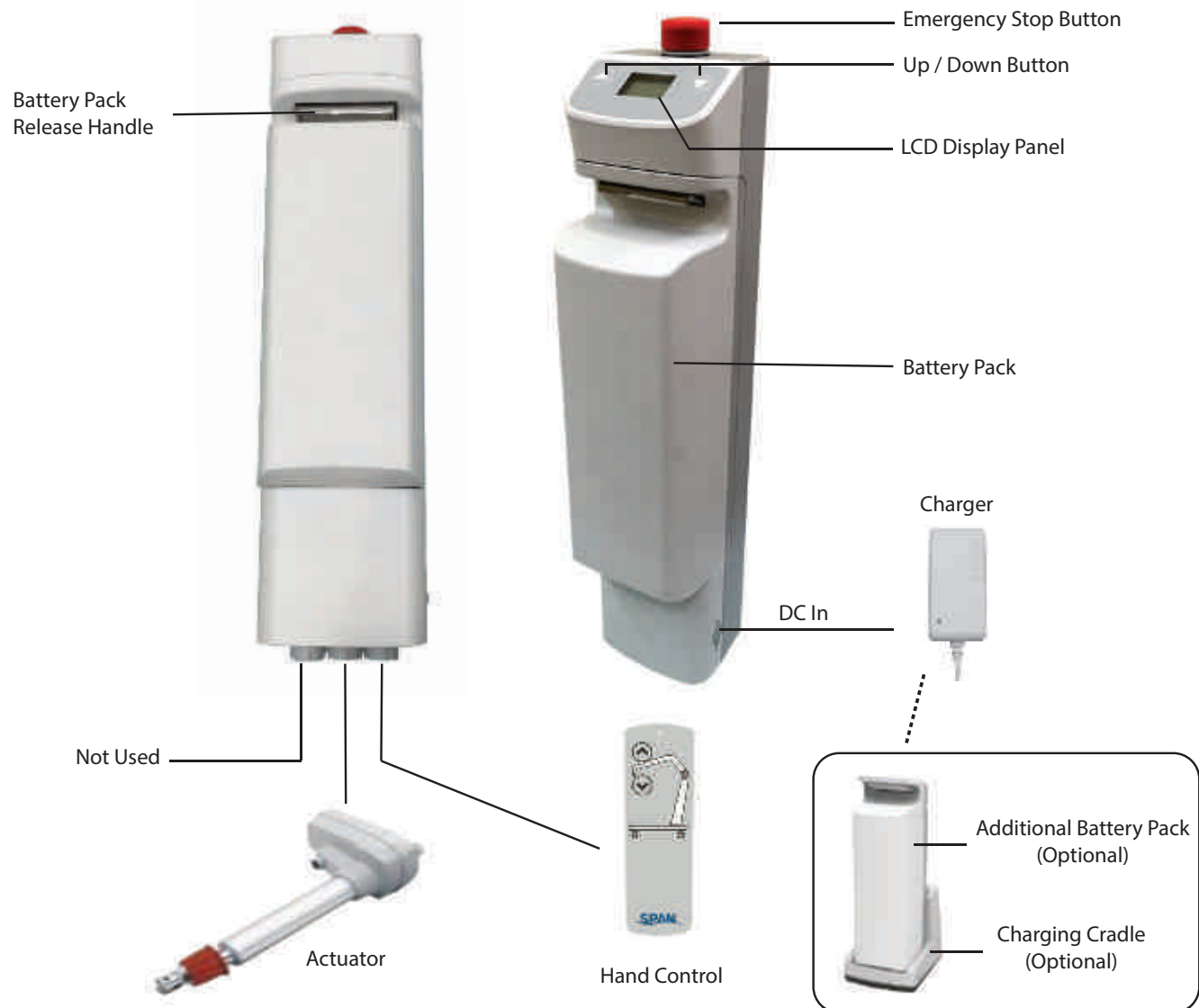

1. Connect Actuator as shown above.
2. Connect Hand Control as shown above.

WARNING!

- Contains a long charger cord that may cause strangulation if used improperly
- Keep long charger cord out of walkway where it poses a tripping hazard
- Have the charger port on the controller facing away from the wall for easy disconnection

Operating Instructions

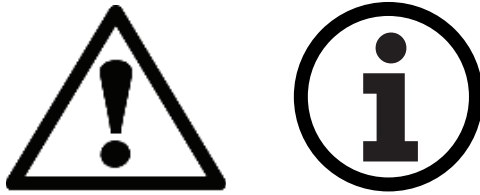

Double check all assemblies for tightness and read operating instructions carefully prior to use.

For optimum performance the lift should be transported and stored in following condition range:

- -25°C to +5°C (-13°F to 41°F), and
- +5°C to +35°C (41°F to 95°F) at a non-condensing relative humidity 0% to 90%
- +35°C to +70°C at a water vapour pressure up to 5 kPa

For optimum performance the lift should be operated in following condition range:

- at a temperature range of +5°C to +40°C (+41°F to +104°F)
- at a non-condensing relative humidity range of 15 % to 90 %, but not requiring a water vapour partial pressure greater than 5 kPa
- 70 kPa to 106 kPa atmospheric pressure

The lift will not have any potential electromagnetic or other interference with other devices.



PREPARATION BEFORE LIFTING

- Twist the RED EMERGENCY STOP BUTTON clockwise.
- Verify the Lifting and Lowering Functions by pressing either the UP or DOWN button on the hand control once.
- Position the base of the lift around or under the object.
- Widen the base and disengage the caster brakes.



Do not attempt to transfer a patient without prior approval of the patient's nurse. Also, do not transfer without having studied the instructions and performed several practices in operating the product. Together (with the patient's doctor, nurse, or medical attendant) select a sling that is both practical and comfortable. The sling selected should be one that serves the needs of the patient, while providing the patient with optimal safety. Never interfere with the lift, unless instructed by the attendant. Have a doctor, nurse, or medical attendant (experienced in the use of the device) present during the first few times the lift is used to transfer a new user.



LCD Display Panel Signs

When the emergency stop button is released, the LCD Display Panel will show one of the four signs below.

- The sign will display for 5 seconds.
- Then the lift will go into standby mode and the sign disappears.
- The lift is ready for use.



Charging: DC Charger or Charging Cradle

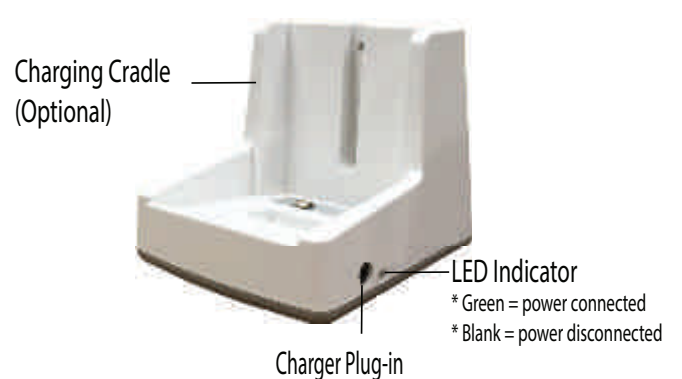

LCD Display Panel Signs - Charging

During charging, the LCD Display Panel will show one of the four signs below.

- The DC Charger must be connected.
- The emergency stop button must be released.
- The battery will not be charged if the emergency button is pressed in.



Operating Lift: Using Hand Control

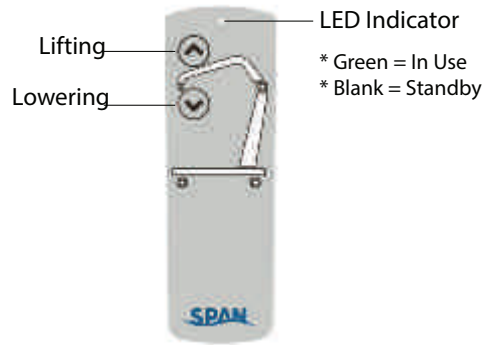

| Button | Press Button | Release Button |
|--------|--------------|----------------|
| | | |
| | | |

Operating Lift: Using LCD Display Panel

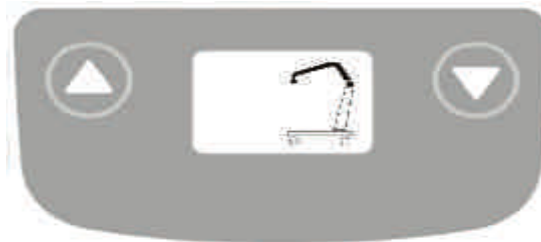

| Button | Press Button | Release Button |
|--------|--------------|----------------|
| | | |
| | | |

Warning! - Battery Low and Charging is Needed

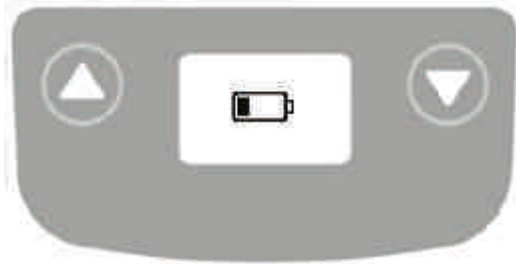

If the battery needs to be charged, the LCD Display Panel will show a blinking low battery sign shown on the left either when the emergency stop button is released or when a button on the LCD Display Panel is pressed.

- Lift is still functioning.
- Buzzer will beep every 2 seconds.
- Battery needs to be charged immediately after use.

Warning! - Overloaded



During lifting if the lift is overloaded, the LCD Display Panel will show the sign on the left and lifting will be deactivated immediately.

- The buzzer will beep 3 times.
- Lowering the lift by pressing the DOWN button is still allowed.
- The emergency stop button must be pressed in and then release the button before further lifting.

Warning! - Charge Battery Immediately



If the battery is critically low, the LCD Display Panel will show the sign on the left either when the emergency stop button is released or when a button on the LCD Display Panel is pressed.

- Lift operation is deactivated.
- Battery needs to be charged immediately before further use.

Available slings compatible with Stand Assist Lift

| Stand Assist Sling | |
|--------------------|------------|
| Sling Model | Sling Size |
| D202MEDLP | S / M |
| D202XLRGLP | L / XL |

| Stand Assist Buttock Strap | |
|----------------------------|------------|
| Sling Model | Strap Size |
| SL-SA669 | Standard |
| SL-SA669B | Bariatric |

| Sling Model | Sling Description |
|--------------|-------------------|
| WP-SA400E-KB | Knee Belt |



If the patient is pregnant or has skin conditions, consult with doctor before use.



ALWAYS check the sling weight capacity is suitable for the patient



All slings are type BF applied parts

FITTING STAND ASSIST SLING

- Position the patient in a sitting position.
- Slide the sling down patient's back to lumbar position.
- Draw the shoulder straps to the front of the patient close to the chest.
- Draw the waist belt around patient's waist and press together to fasten.

Attach the shoulder straps to the hooks.

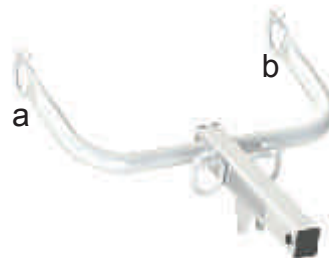
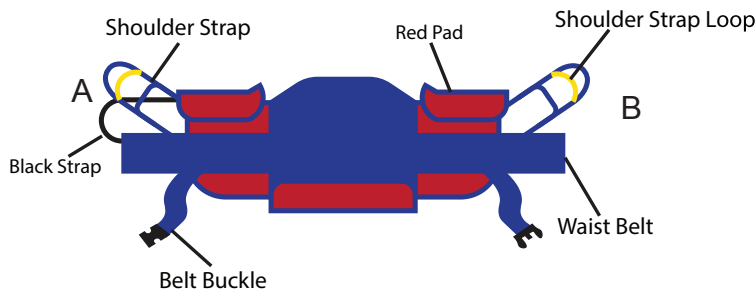

Sling Loop Options

LONG LOOP

CENTER LOOP

SHORT LOOP

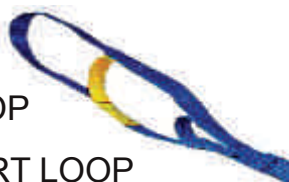

LONG LOOP - reclined position

CENTER LOOP - semi reclined

SHORT LOOP - most upright



BEFORE LIFTING THE PATIENT, PULL ON EACH SLING LOOPS TO ENSURE THE LOOP IS HOOKED ONTO THE SPREADER BAR PROPERLY

OR

For sling application

- Place sling behind seated patient with the 2 red pads under the arms.
- Cross the adjustable chest belt over and fasten it securely using the buckle (adjust for comfort).
- Cross the short black strap over and pull the left loop strap through the black strap.
- Hook the two loop straps to the hooks ("A" to "a" and "B" to "b") on the lift boom using the same hook and loop sequence on each side.
- The black strap should loop around both shoulder straps and will be straight across in front of patient to stabilize the sling during lifting.
- Have patient grasp the arms of the boom and tilt head back slightly.
- Make sure the patients feet are firmly on the platform and knees are touching the kneepads with kneecaps just above the padding.
- Use the lift to complete the lift and pivot transfer.

FITTING STAND ASSIST BUTTOCK STRAP

DIAGRAM 1



- Check sling weight capacity for the patient being lifted. Do not exceed maximum safe working load.
- Review following procedures carefully prior to attempting lift. Call with any questions.
- Position the sling around the buttocks of the patient. This sling is designed to support the middle and lower part of the body.
- Attach the sling strap “A” to the hook “a” on the boom of the F500S lift as in Diagram 1. Bringing the other side around the back of the patient’s buttocks (to fit like a park swing) and attach to hook “b”.
- Position sling so it gives the greatest support to middle and lower part of the patient when being lifted.
- Fit the Stand Assist sling following “Fitting Stand Assist Sling” instructions

⚠ the Buttock strap can be used only IN CONJUNCTION WITH the Stand Assist sling, never by itself. These slings are designed to compliment one another in providing the greatest comfort and security for the patient being transferred.

FITTING KNEE BELT

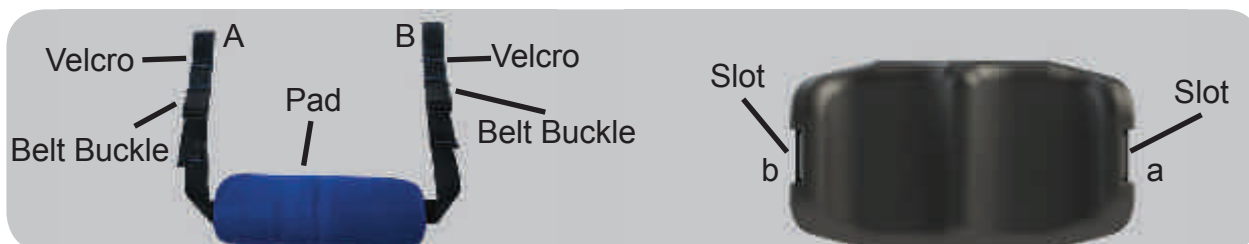

- Pull open to Velcro.
- Slide the Velcro through the slot. (“A” to “a” and “B” to “b”)
- Wrap the Velcro around the slot and press the Velcro together.
- Check to make sure the belt is strapped to the kneepad
- Repeat for the other side.
- Make sure the pad is facing the back of your lower legs.
- Adjust the strap on the belt buckles to fasten the knee belt and for comfort.

LIFT AND TRANSFER FROM BED

- Fit sling as described in “Fitting Stand Assist Sling”.
- Push lift towards patient. Open the base of the lift.
- Position patient’s feet on the footplate and knees against the knee pad.
- Attached the sling straps to the hooks.
- Have the patient’s hands holding the handles. For patients who cannot hold the handles, have them hold their arms around the chest.
- Press the “UP” button on the hand control.
- Before the patient’s body has lifted from the bed, stop and make sure the sling is secured and patient’s knees are against the knee pad.
- The patient should be comfortable with the pressure under the arms. If not, adjust the sling and try another loop option to release pressure.
- Press the “UP” button until the patient’s body has completely left the bed.
- Transfer to another object can be done at this position without the patient attending a full standing position.
- Close the base, and pull the lift away from the bed.
- Lower the patient to the object intended.
- To lift patient in a standing position, continue to lift until the patient’s knees are locked in a standing position.
- At the standing position, patient’s knees may move away from the knee pad.
- Close the base, and pull the lift away from bed.
- Lower the patient to the object intended.
- Reverse the above procedures when lowering the patient to the object intended.

LIFTING HINTS

- Prior to beginning a lift, have the patient lean slightly back and look at a 45 degree angle to the ceiling; this help position the sling; this is recommended only at the start of lifting.
- Try the sling straps in various color positions to establish best fit.
- Always insure the same color straps on each side are attached to lift.
- Should patients have a larger girth in mid section or back side area try the optional buttock strap to help with initial lift leverage.
- Remember this lift is designed for pivot transfers and it is not necessary to lift to full upright position; as long as the patients body clears the bed or the chari and vice versa, you can move the lift and place patient in new postion.



It is not uncommon for the strap to loosen and drop down as lift proceeds.

Maintenance & Inspection



- The operator of the lift shall inspect the lift before each use. Check all bolts for tightness. Make sure the base can be easily widened, and that all lift parts are in place. Make sure that casters can be turned freely, and that caster brakes can be engaged. Make certain all necessary items (i.e. slings, and wheelchairs, etc.) are ready for use.
- At least once a month, the lift should be thoroughly inspected by a person qualified to recognize any signs of wear and tear, and looseness of bolts or parts. Replace any worn parts immediately.
- To lubricate, put a drop of oil on the following points when the lift is placed into service and every month thereafter: Top of Mast, Spreader Hinge, and Caster Axles.
- With proper use and care, the expected lifetime of the lift is 10 years or 20,000 cycles.
- The expected lifetime of the electrical components are 3 years.
- Contact Span-America for recycling information

| | First Received | Monthly | Every 3 Months |
|---|----------------|------------|----------------|
| Boom & Spreader Bar | | | |
| Check connections between boom and spreader bar for improper connection, | ● | ● | |
| Check connections between boom and mast for improper connection, looseness or wear. | ● | ● | |
| Check the boom for bending and deflection. | | ● | |
| Mast | | | |
| Check the mast for bending or deflection. | ● | ● | |
| Base & Foot Pedal | | | |
| Check bolts and nuts for looseness. | ● | ● | |
| Check casters and axle bolts for tightness. | ● | ● | |
| Check rubber parts on the casters for deflection. | ● | | ● |
| Apply grease to caster ball bearings if needed. | | | ● |
| Check welding joints for rust and crack. | | ● | ● |
| Actuator & Control Box | | | |
| Make sure the control box is firmly affixed to the mast. | ● | ● | |
| Make sure the actuator is secured to the boom and mast with pins and key rings. | ● | ● | |
| Make sure actuator plug into control box is not loose. | ● | ● | |
| Sling & Sling Hardware | | | |
| Check sling for wear. | ● | ● | |
| Check sling hardware every time before use. | ● | ● | |
| Lift Cleaning | As Needed. | As Needed. | As Needed. |

Cleaning and Disinfecting

Cleaning of the lift

- Use pH-neutral detergents only.
- Remove the battery from the controller
- Clean lift surfaces, control box and hand control with a damp cloth using pH-neutral detergent.
- Remove debris and hair from the casters and make sure the casters can spin and swivel freely.



Solvents or strong liquids or abrasive cleaning products will damage the surfaces of the lift.

Cleaning of the sling

- Check with sling label for washing condition.
- As for minor cleaning between patient uses, we recommend wipes with water-soluble soap or isopropyl alcohol.
- For slings with rigid supports, remove the plastic inserts before washing. (Look for an opening near the plastic inserts for removal)
- Machine wash warm or cold.
- Do not wash with other colors.
- Air dry or very low dryer heat.



- DO NOT USE BLEACH.
- DO NOT clean or wash disposable slings.
- REPLACE a sling when it show signs of deterioration.

Deterioration of sling

- Contact Span for “Guideline for Identifying Deteriorated Slings” if needed.

Disinfecting of the lift and sling

- Inspect slings prior to each use for contamination from previous use.
- Use isopropyl alcohol for any disinfection purpose.



- Wash a reusable sling for serious contamination
- Replace a disposable sling for any contamination
- Reusing a contaminated sling can cause serious bacterial infection

Troubleshooting Guide

The following list of encountered problems and solutions will assist you in determining what may be causing your patient lift not to function as designed. If you have a problem occurring which is not listed below please contact your dealer or technical support for help. Do not attempt to repair or replace components or parts on your lift as this may void your warranty or cause further problems that may result in patient injury. Stop using your lift immediately if it is not functioning correctly or any warning beeps are heard.

I need to re-charge my batteries often or they fail to hold a charge when I charge them.

- Replace the batteries or battery pack as they are at the end of their life cycle
- Batteries should be changed every 18-24 months depending on usage

The actuator will either go up or down but not both

- Replace your hand control as it is at the end of its life cycle
- Your control box may be malfunctioning

There is a grinding sound inside the actuator when lifting

- Replace your actuator as the internal gears are stripped

The actuator stops and starts while lifting or lowering

- Replace the batteries or battery pack as they are at the end of their life cycle

My lift will not operate even though it shows the batteries are charged

- Unplug the AC power cord from the control box as the lift will not work when the control box/charger is connected to AC Power.
- Check to make sure the hand control is properly inserted all the way into the control box port.
- Check to make sure the actuator plug is properly connected and inserted all the way into the control box
- Your hand control needs to be replaced as it is at the end of its life cycle

If there is a problem you could not solve, please contact your dealer for assistance.

Emergency Lowering Mechanism

Contact your dealer immediately if standard troubleshooting techniques do not correct the failure. Do not attempt to lift until all failure and safety issues have been resolved.

In case of lift failure, please follow the procedures below to safely lower the user.

The Emergency Lowering Device is located at the top of the actuator shaft. It is intended for use if the actuator or electronics fail to operate while the patient is suspended in midair.

The device consisting of a plastic collar ring that should be first pulled down and turned clock-wise continually until the patient has been lowered.

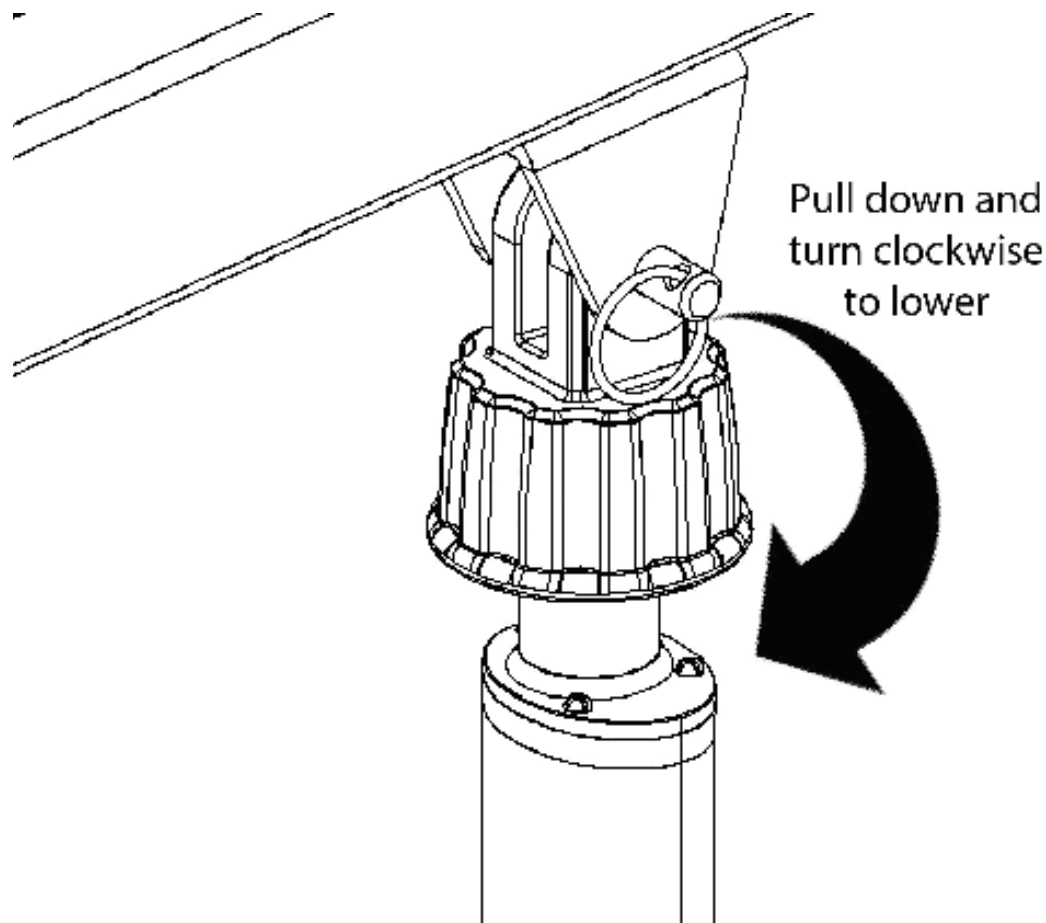

NOTE:

THE EMERGENCY LOWERING DEVICE IS INTENDED FOR USE DURING LIFT FAILURE. THIS DEVICE WILL ALLOW LOWERING OF PATIENTS ONLY. PLEASE CONTACT YOUR DEALER IMMEDIATELY IN CASE OF FAILURE.

WARRANTY POLICY

Span-America (“Span”) offers a limited warranty on all patient lifts, slings and accessories to be free of defects in workmanship and product performance. This warranty extends only to the original purchaser and is non-transferrable. All warranty claims must be submitted by the authorized dealer or distributor who originally sold the product with proper proof of sale and serial number where applicable. Prior Return Authorization (RA) from Span is required for all warranty replacements. Span reserves the right to repair or replace only defective parts or accessories in lieu of a complete new patient lift. The repaired or replacement part shall be warranted for a period equal to the remainder of the warranty period of the defective part.

Span does not provide advance replacements for warranty claims. For situations where an end user requires a replacement in advance and before a warranty item can be returned, dealer or distributor must purchase the replacement at full cost. All freight charges for the replacement are the sole responsibility of the dealer or distributor. When end user returns warranty item and item proves to be defective, Span will issue full credit for the replacement less freight charges.

Product returned without RA number clearly marked on the package or product returned later than 30 days after authorization will be refused and returned at sender’s expense. Final disposition of warranty claims will be determined at the sole discretion of Span. Warranty claims will be denied for any of the following: product abuse or misuse, accidental or malicious damage, improper installation, product used with parts, components or accessories with quality or specifications incompatible with product, adulterated product, user neglect, failure to maintain and service product as specified in the owner’s manual or care tag, serial number removed or defaced, or normal wear and tear.

Span warrants the following products and components beginning from the purchase invoice date for the specified time period:

| WARRANTY PERIOD | PRODUCT OR COMPONENT |
|------------------------|--|
| Three (3) Years | Patient lift frame or spreader bar |
| Two (2) Years | Actuator, control box, pendant, charger, weigh scale, Stand Aids, or casters excluding normal tread wear |
| One (1) Year | Battery or hydraulic pump |
| Six (6) Months | Reusable fabric slings |

Single Patient Specific slings are designed for limited use with one patient and may not be laundered. Span will replace any disposable sling found to have a manufacturing defect. Normal wear and tear will not be covered under warranty.

This warranty expressly excludes wearable components including but not limited to foam parts and caster tread. Furthermore, this warranty is void and null for product that has not been purchased or paid for in full.

RETURN GOODS POLICY

Patient lifts may not be returned unless the wrong lift is shipped in error by Span or the lift is heavily damaged or defective out of the box. For all other items, purchaser may request a RA for purchased goods within thirty (30) days of purchase invoice date. All returns must be received by Span no later than thirty (30) days after authorization or the RA will be voided. Return package must be clearly marked with the RA number or the package may be refused and returned at sender’s expense. Patient lifts are subject to a minimum restocking fee of 25% or more. Please note that patient lifts being returned must be in the original carton with all parts, components and packing materials included. Failure to comply with this requirement will incur higher restocking fees or a rejection of the return. Slings, parts and accessories may only be returned if they have not been used. There are no exceptions to this provision.

All freight charges are the sole responsibility of purchaser when any of the following occurs: (i) ordering error where an incorrect item is shipped in accordance with purchase order, (ii) an order is cancelled while in transit or (iii) delivery is refused by customer.

Span reserves the right to issue credit amounts based on strict adherence to this policy.