



CONSUMER AFFAIRS
★★★★★ 4.8/5

1100 Straight Stairlift

The Stairlift Designed for Your Everyday



“My Handicare stairlift gives me complete independence and fills me with total confidence in moving around my home safely every day.”

Features

Patented Multi-Drive Technology

Ultra Slim Rail

Constant Charge

Compact and Foldable

Easy to Use and Maintain

Available Powered Footrest and Seat Swivel Options



Safe Working Load (SWL)

30–45°: 309 lb (140 kg)

46–50°: 287 lb (130 kg)



Warranty

1100: 2 years

Motor and gearbox: 10 years

Regain your independence and conquer the struggles of staircases.

Handicare offers stairlift solutions that provide freedom of movement throughout your home, allowing you to age in place free from everyday obstacles. Our compact and customized stairlifts can be installed anywhere. We have millions of satisfied customers worldwide with a dealer network across North America to support you.

Ultra slim profile. Revolutionary drive system.

The Handicare 1100 Straight Stairlift features next generation technology with an ultra-streamlined design that takes up less space on your stairs. The Patented Multi-Drive Friction System will ensure your stairlift is operating at peak levels at all times with no reduction in performance ever.

With the 1100, we eliminated the traditional rack and pinion model and invested in a friction drive system to power our next gen stairlift. We've achieved a quieter, smoother, more robust stairlift that's much easier to maintain. The contemporary design allows the 1100 to blend into any environment, becoming a complementary piece in your home.



Did You Know?

Every three minutes
a Handicare stairlift is
installed around the world.



Features for your safety and convenience.



Compact

The 1100 folds up easily maximizing the space for family members to go up and down the stairs as needed.

We know back pain and aches can occur anytime, that's why we made our 1100 easy to upgrade. Powered footrest and seat swivel can be added after installation for your convenience.



Easy to Use

Ergonomic and intuitive to use, the joystick on the armrest smoothly operates the 1100.

Send for your stairlift at the touch of a button with the included remote control. Two are included with your 1100 with holders for both the top and bottom landings.



Easy to Maintain

Pet owners rejoice, the 1100 features four brush heads that constantly clean the rail from dust and hair, ensuring your lift is always spotless. The tooth rack free design also eliminates the necessity for grease on the rail offering a clean finish today and tomorrow.



Always Charged

The 1100 comes standard with Continuous Charge, your lift is always being charged anywhere on the track!



Did You Know?

Handicare's **EasyGlide Technology** ensures an exceptionally smooth ride up and down the stairs; when you reach the top landing or bottom the 1100 gently glides to a halt, avoiding an abrupt sudden stop.



Retractable Seatbelt

The 1100 comes equipped with an easy-to-use retractable seat belt, a standard feature that provides added security when safely seated in your stairlift.



Stairlift Myth

"Maintaining a stairlift is expensive."
Cost-effective parts, maintenance friendly design, and Handicare's industry-leading warranty make the 1100 the smart choice.



Patented Multi-Drive Friction Technology

We've built multi-drive into a stairlift! In the unlikely event of a motor issue, you have three others to transport you safely to the top or bottom of the stairs. An emergency stop button is also located on the bottom of the chair.



Safety First

The optional powered footrest allows you to fold and unfold the footrest without having to bend down, an anti-slip texture on the footrest provides a better foot grip when seated and departing.

The 1100 is also fitted with multiple safety sensors which stop the stairlift whenever it runs into an obstacle.



Swivel Automatically

The optional powered swivel makes it easy to get off the lift at the top of landings, simply hold the toggle switch in the direction of the landing to turn the seat for a controlled departure.

With 80 degrees of tilt, you face more of your top landing providing a greater security blanket when getting up from your 1100.

A Stairlift Suited for Any Interior

We designed the 1100 to be a smart, stylish complement to everything else in your home. The contemporary design is welcome in any home décor and is available in a warm vanilla beige upholstery.

Featuring our comfortable Style Seat in a leatherette finish, the seat surface is easily wipeable and cleans effortlessly.

The ultra slim rail beautifies the 1100, simply there is no other rail on the market that competes with its overall look and sleek profile, a non-obtrusive design that quietly blends in with your staircase.



1100 Accessories



Slide Track

The Slide Track is ideal for hallways where access is required through doorways either at the top and/or bottom of the stairs. It automatically slides the track clear of any obstacles while the stairlift moves up or down the track.

No need to bend down or wait for a hinge to fold, this state-of-the-art solution is fully automatic.



Easy Hinge

The Easy Hinge can be folded out of the way to clear hallways when the stairlift sits in a parked position at the top of the stairs – eliminating a trip hazard. The lightweight Easy Hinge is manually folded down with little effort and is raised with the assistance of the gas strut.



Zero Intrusion

This unique solution is designed for homes where stairs finish at the door, particularly seen in basements. Zero Intrusion eliminates the rail overrun, allowing for our 1100 Straight Stairlift to be installed without making any modifications to your home.

Frequently Asked Questions

We strive for 100% customer satisfaction. That is why we go the extra mile to offer you the highest standards of service and answer your questions in the best way possible. We partner with the industry's leading dealers that have a track record of exceptional local support.

We have listed some of our customers' most frequently asked questions. Should you have further questions, please contact your local dealer for a consultation.



Can a stairlift be installed on my staircase?

Handicare offers a wide selection of stairlifts for straight and curved stairs. With a variety of lift models we are able to provide a suitable solution for each setting regardless of whether the stairs are narrow, steep, curved or long, indoor or outdoor. Handicare always has a solution for your staircase.

Does it take major renovation to install a stairlift in my home?

No! The 1100 Straight Stairlift is simply installed onto the stair treads. Because it is fixed to the staircase, you don't have to worry about any further modification to your home.

How do I enter and exit from a stairlift?

Entering and exiting the 1100 is made easy, simply unfold the seat and footrest, sit down while securing the seat belt. When it's time to exit your 1100 you can use easily swivel the seat to face your landing for a controlled departure.

Can others still use my stairs?

Compact and ultra slim, the 1100 can easily be folded up when not in use to allow for easy pass-through for family members and friends.

What happens to my stairlift during a power outage?

A power failure is no reason to worry. Your Handicare stairlift will use its batteries to remain operational and can still be used for at least 10 rides up and down the stairs. The 1100 features Constant Charge, providing charging anywhere on the track so it is ready for use 100% of the time.

How do I know when batteries need to be replaced?

The 1100 is equipped with a fault display behind the power pack, simply review the code and call your local dealer who can easily look up the code and inform you if the battery needs to be replaced.

Generally the batteries will last for three years depending on usage.



1100 Fact!

The 1100 can be installed quickly – our dealers are trained to be efficient; stairlift installation should be quick and pain-free and shouldn't interfere with your day.

1100 Straight Stairlift

Specifications

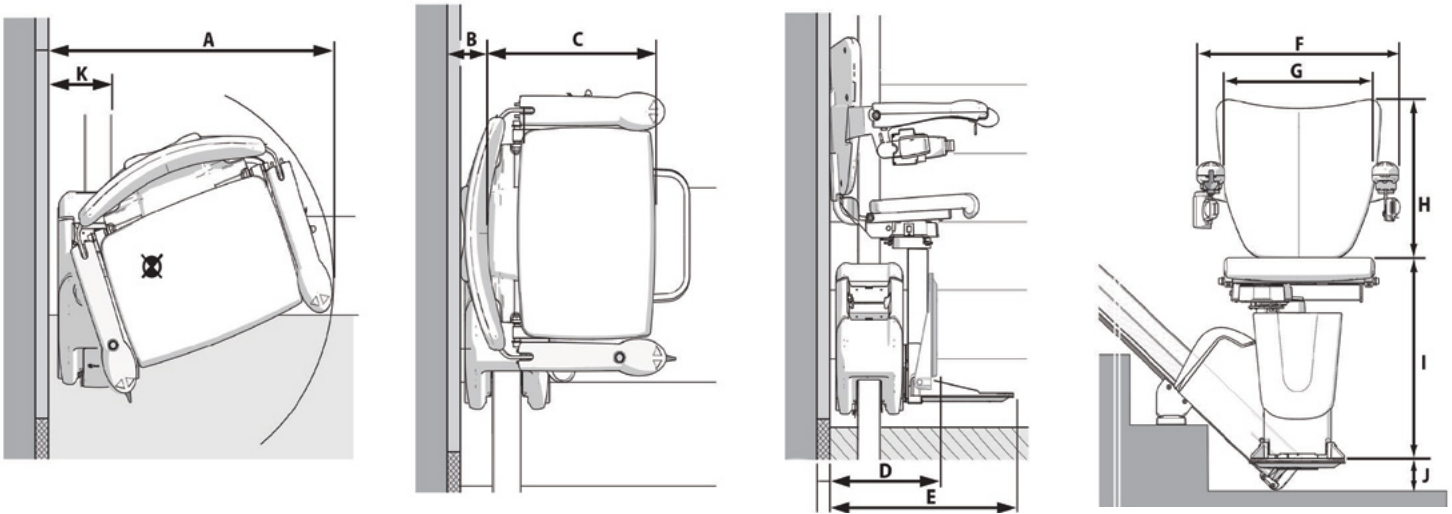

1100 Style Seat Dimensions

Safe Working Load (SWL)

30–45°: 309 lb (140 kg)

46–50°: 287 lb (130 kg)

Staircase Angle

30–50°

Speed

0.5 ft / sec (0.15 m / sec)

Some of the dimensions depend on the characteristics of the staircase in the home. Handicare reserves the right to alter designs and specifications without prior notice.

A Swivel radius, minimum	25.4 in (645 mm)
B Wall to inner seat back	2.4 in (60 mm)
C Seat depth	15.4 in (390 mm)
D Folded width to footplate, minimum	12.6 in (320 mm)
E Open width to edge footplate, minimum	20.9 in (530 mm)
F Armrest width, external	22.6 in (575 mm)
G Armrest width, internal	17.7 in (450 mm)
H Seat back height	15.7 in (400 mm)
I Footplate to seat height	16.9–20.5 in (430–520 mm)
J Footplate height, minimum	2.75 in (70 mm)
K Track intrusion into staircase, minimum	6.3 in (160 mm)

HANDICARE

10888 Metro Court, St. Louis, MO 63043

Toll Free: 866.891.6502 | Fax: 314.692.7858

customerservice.northamerica@handicare.com

www.handicareusa.com

81 Romina Drive, Concord, ON, L4K 4Z9

Toll Free: 877.304.5438 | Fax: 416.260.0256

customerservice.northamerica@handicare.com

www.handicare.ca

Are you ready to take back your independence with the 1100?

Call 1-888-637-8155 or visit
www.handicareusa.com / handicare.ca