

# OWNERS MANUAL

## EXTREME TILT WHEELCHAIR



At Power Plus Mobility, we care!

Thank you for choosing a wheelchair from Power Plus Mobility Inc. We are always improving in our ways to serve you better and would love to hear your questions or comments about our literatures, the reliability of our chairs and service you received while making the decision of choosing our wheelchair. Please feel free to contact us via our email address: [customer@powerplasmobility.com](mailto:customer@powerplasmobility.com)

### QUESTIONS REGARDING YOUR WHEELCHAIR?

The best way to get your questions answered is by your authorized wheelchair dealer since they know your wheelchair and have the training for it. Please fill in your dealers information below so you have it handy just in case you have any questions or concerns about your wheelchair. Your dealer will guide you on the right direction to take any further steps.

### PLEASE FILL BELOW FOR YOUR INFORMATION:

Dealer name: \_\_\_\_\_

Dealer Address: \_\_\_\_\_

\_\_\_\_\_

Tel: \_\_\_\_\_

Serial #: \_\_\_\_\_

Purchased Date: \_\_\_\_\_

# CONTENTS

Warranty Information	1
Wheelchair Specifications	2
Maintainance Guiude	3
<i>Cleaning</i>	
<i>Lubrication</i>	
<i>Safety and Handling</i>	
Maintainance Guide	4
<i>Leaning</i>	
<i>Maneuvering Ramps, Curbs, Stairs</i>	
<i>Transferring in a Wheelchair</i>	
Anti-Tippers	6
<i>To Remove Anti-Tipper</i>	
<i>To Adjust the Height</i>	
Foot rest	7
Leg rest	8
Arms	9
Angle Adjustable Back	10
Rear Wheels	11
Casters	12
Wheel Combinations	13
Tires and Wheel Locks	14
Cylinder Setup for Seat Height	15

Valued Customer,

At Power Plus Mobility we manufacture top quality **CANADIAN MADE** products. Your wheelchair should provide you with many years of service, but like any piece of equipment, it will require proper care and service for it to perform efficiently.

However we suggest you regularly inspect your chair, checking for loose fasteners, excess play and damage. We also strongly recommend that regular maintenance be done by your servicing dealer.

Please complete your **WARRANTY REGISTRATION CARD** and return it to us at Power Plus Mobility Inc.

Also please read this manual to help understand the proper operation, safety and maintenance of your new wheelchair.

## LIMITED WARRANTY

Power Plus Mobility guarantees all parts of our wheelchair to be free of defects in workmanship and materials for a period of two years from the date of purchase. “Wear” items such as tires, tubes, arm-pads and upholsteries are excluded from this warranty. In addition the frame and cross-braces are guaranteed to be free of defects in workmanship and material (to the original purchaser) for a period of 5 years.

This warranty is invalid if the chair has been damaged by accident, misuse, neglect, improper application, unauthorized service repair or the addition of non-factory approved accessories.

Power Plus Mobility will repair or replace defective parts as required. A return authorization must be obtained and the parts returned to us freight prepaid, within the warranty period. Labour and freight charges incurred for replacements or repairs are not covered.

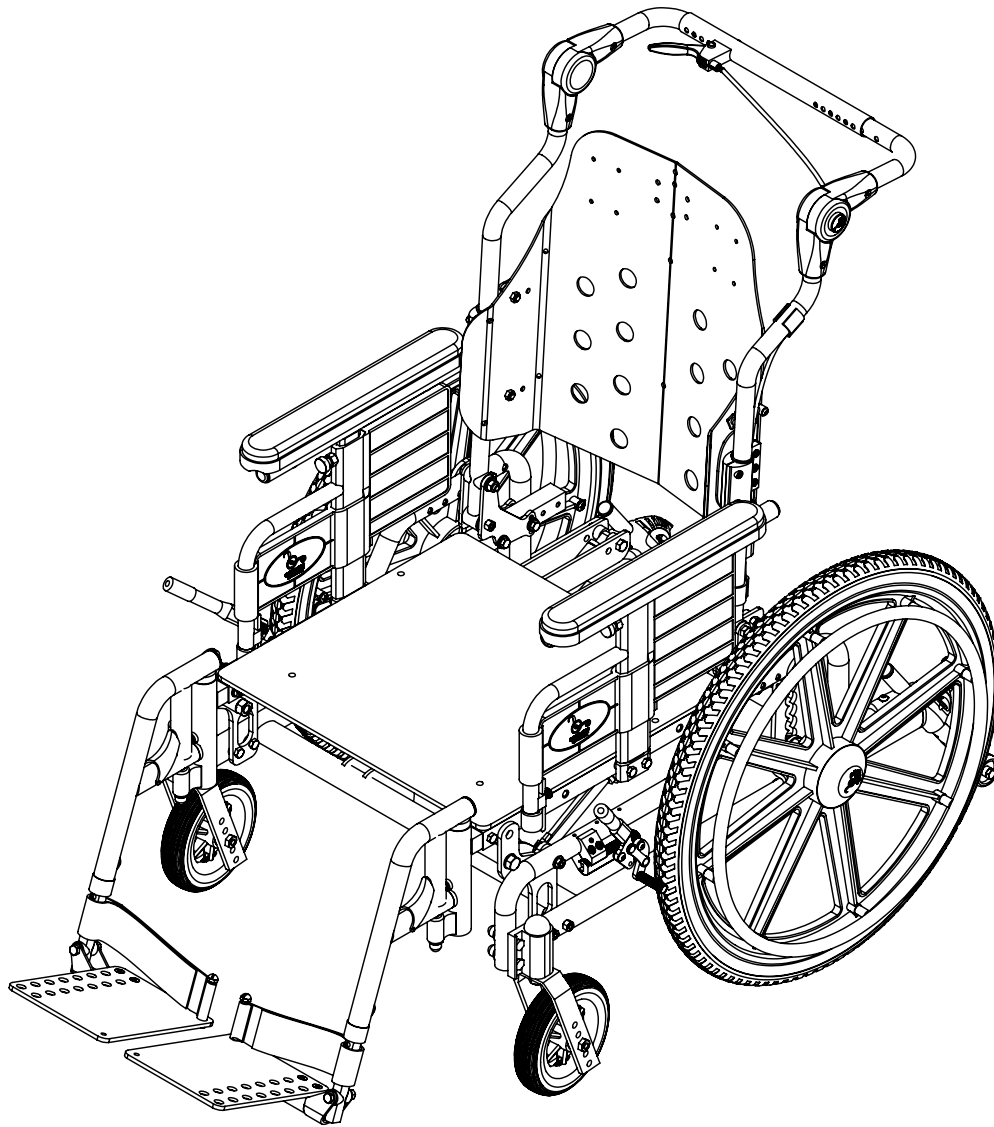

SPECIFICATIONS	Extreme
SEAT WIDTH:	14" TO 36"
SEAT DEPTH:	(ADJUSTABLE): 16" TO 24"
SEAT HEIGHT:	(ADJUSTABLE): 12.25" TO 18.25"
Tilt ANGLE:	0° TO 25°
BACK ANGLE:	(ADJUSTABLE): 0°, 5°, 10° OR 15°
ADJUSTABLE STROLLER HANDLE:	0° TO 180°
WEIGHT CAPACITY:	UP TO 600 lbs.
WEIGHT OF CHAIR:	60 lbs. (APPROXIMATELY)
	DYNAMIC TILT ADJUSTMENTS 0° TO 25°
	TWO-WAY LOCKING GAS STRUT
	SINGLE RELEASE, DUAL CYLINDERS
	STANDARD LOCKOUT COLLARS

Your wheelchair is designed to give you many years of trouble-free use with proper care. Some servicing can be done at home, but we recommend that periodic maintenance be performed at your dealer.

Service frequency depends strongly on the type of use and your dealer can best advise you on the time interval.

## **CLEANING**

All chrome and painted parts can be cleaned with a mild non-abrasive cleaner such as window cleaner. Stubborn spots or rust can be removed with automotive chrome cleaner.

The arms and nylon upholstery should be cleaned with a mild soap and water solution. Both should be rinsed well with clean water to remove all soap residues. The molded wheels and casters should also be cleaned with a mild soap and water solution.

## **LUBRICATION**

Your wheelchair has been made with low friction plastic, steel, aluminum and polished chrome to reduce friction and wear. However a light use of thin lubricant, such as WD40 or silicone spray will reduce friction and wear, making your chair easier to use.

## **SAFETY AND HANDLING**

The safe handling of your chair depends on understanding the purpose and function of your particular wheelchair model. Recognizing the chairs' limitations will increase your confidence level.

## LEANING

Leaning should be avoided when possible, as this weight transfer will reduce your chair's stability. When leaning forward or sideways make sure the casters are turned in the direction you are leaning as this will lengthen the wheel base, increasing stability. Also make sure the wheel locks are engaged, to prevent your chair from rolling.

## MANEUVERING RAMPS, CURBS, STAIRS

Lean forward in chair, putting weight over front casters when going up inclines. When going on descending inclines do so slowly by controlling your speed using the hand-rims and not the wheel. To mount a curb use the tipping method, pull the chair backwards and over the curb. To descend a curb do your tipping and either pull yourself down backwards or roll yourself forward and down very slowly.

It is a definite no-no to use your chair on an escalator, find the nearest elevator instead. Going up or down stairs should be done with at least two attendants at all times.

## TRANSFERRING IN A WHEELCHAIR

Attendant assistance is recommended to stabilize the chair and help in lifting you, if necessary. Transfers are best accomplished by following these guidelines:

- Use a chair with detachable or flip back arm.
- Position your chair as close as possible to the transfer object and engage your wheel locks to prevent movement.
- Try to transfer to objects of the same height or close to.





Your Anti-Tippers are used to prevent your chair from tipping over while in tilt. These can be removed. However, they must never be removed when using chair.

**TO REMOVE ANTI-TIPPERS:**

Loosen the bolt (1) and remove it from the frame

**TO ADJUST THE ANTI-TIPPER HEIGHT:**

Pull on (3) while moving (2) to your desired position release (3) to lock into place

\*Please adjust your Anti-Tippers to a safe height (maximum 2” from the ground). Whenever the seat height is adjusted by wheels the Anti-Tipper height must be adjusted as well.

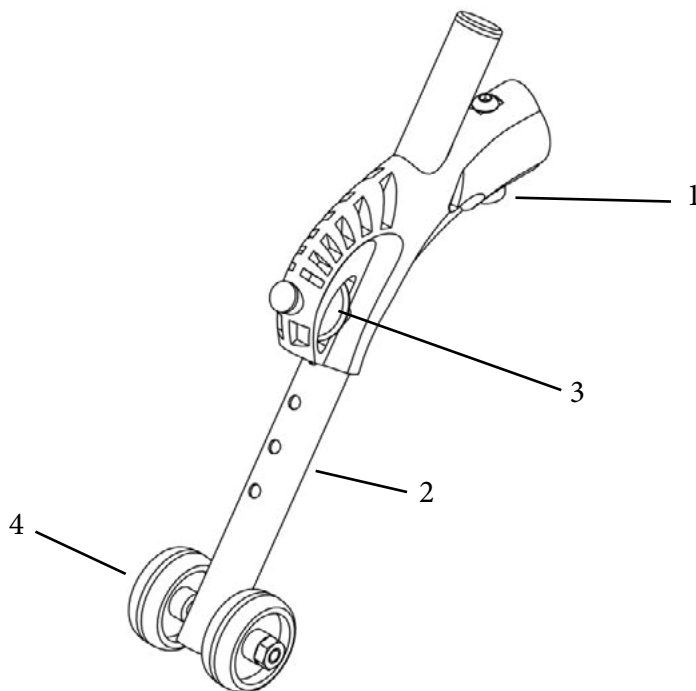

Number	Description	Quantity
1	Bolt	1
2	Anti-Tipper Height Adjustment Rod	1
3	Pull and Release Pin	1
4	Anti-Tipper Wheels	2

The foot rest on your chair is designed to swing away and removes easily. To swing away, remove feet from the footplate (1) and fold foot-plates up. Then push the release handle (2) on the foot rest locking mechanism. It will swing to the side of your chair, and could then be removed by lifting it straight up and off the locating pins (3). To replace hold foot rest at the side of your chair, locate onto mounting pins, allowing it to drop all the way in, and then push forward until it locks into place.

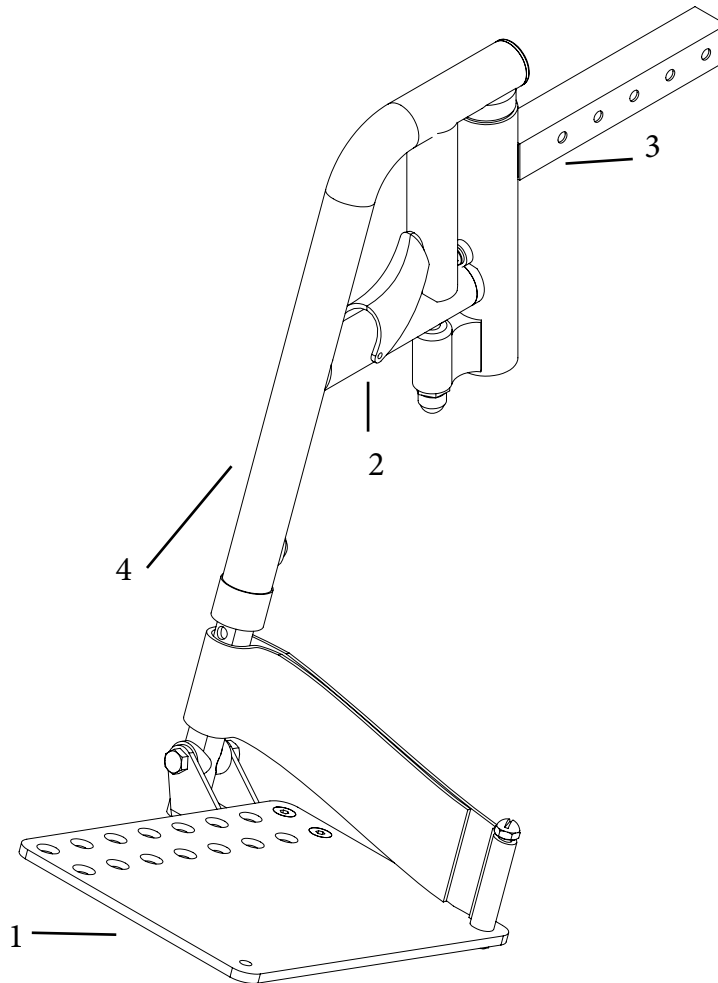

Number	Description	Quantity
1	Foot Plate	2
2	Releasing Handle	2
3	Mounting Pins	4
4	Foot rest Extension Tube	2

Your leg rest is designed to be removed and replaced the same as your foot rest. However, it is advisable to remove and replace your leg rest while it is in a down position. Lifting on the foot-plate raises the leg rest and it will automatically lock at the raised position.

**OPERATING YOUR Leg rest:**

Locate 1 into 3 and swing into place. This should allow 4 to lock into place with 3. (Make sure your leg rest is locked into place before using. To remove foot rest, pull release handle 4, swing leg rest sideways and lift leg rest upwards. To raise leg rest move lever 5 and lift leg rest. To lower leg rest, pull 5 till lowered. To adjust leg length height, remove screw 8 and adjust to required height.

\*For low floor to seat height on chair, shorter leg rest height extension tube is required.

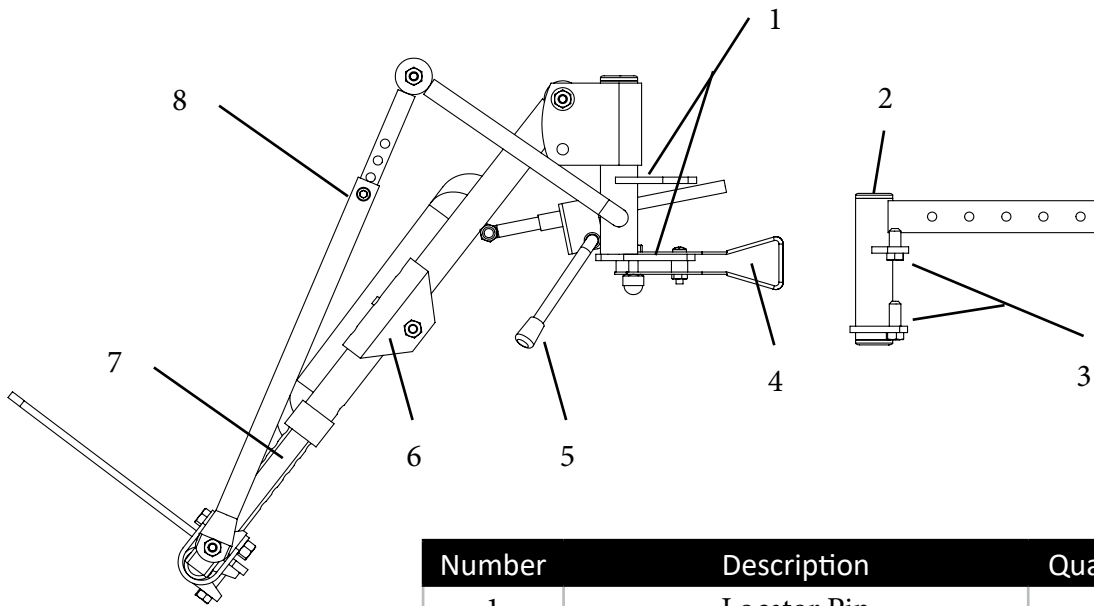

Number	Description	Quantity
1	Locator Pin	1
2	Front Post	1
3	Locking Pins	1
4	Release Handle	1
5	Elevating Trigger	1
6	Calf Pad Height Adjustment	1
7	Leg Rest Height Extension Tube	1
8	Socket Cap Screw	1

Your chair has standard fixed height or adjustable height arms. Either style may be easily removed from the chair.

**TO REMOVE ARMS:**

Push down on the arm removal latch (3). It will catch and remain in the open position. Then lift arm top (1) straight up evenly near the back of the arm. When the arm is returned to the closed position and pushed down the locking pin will relock.

**TO ADJUST ARMS:**

Adjustable height arms provide 5 adjustment positions. Pull out and hold the height adjustment release knob. Then lift up or push down the arm top to achieve the preferred height.

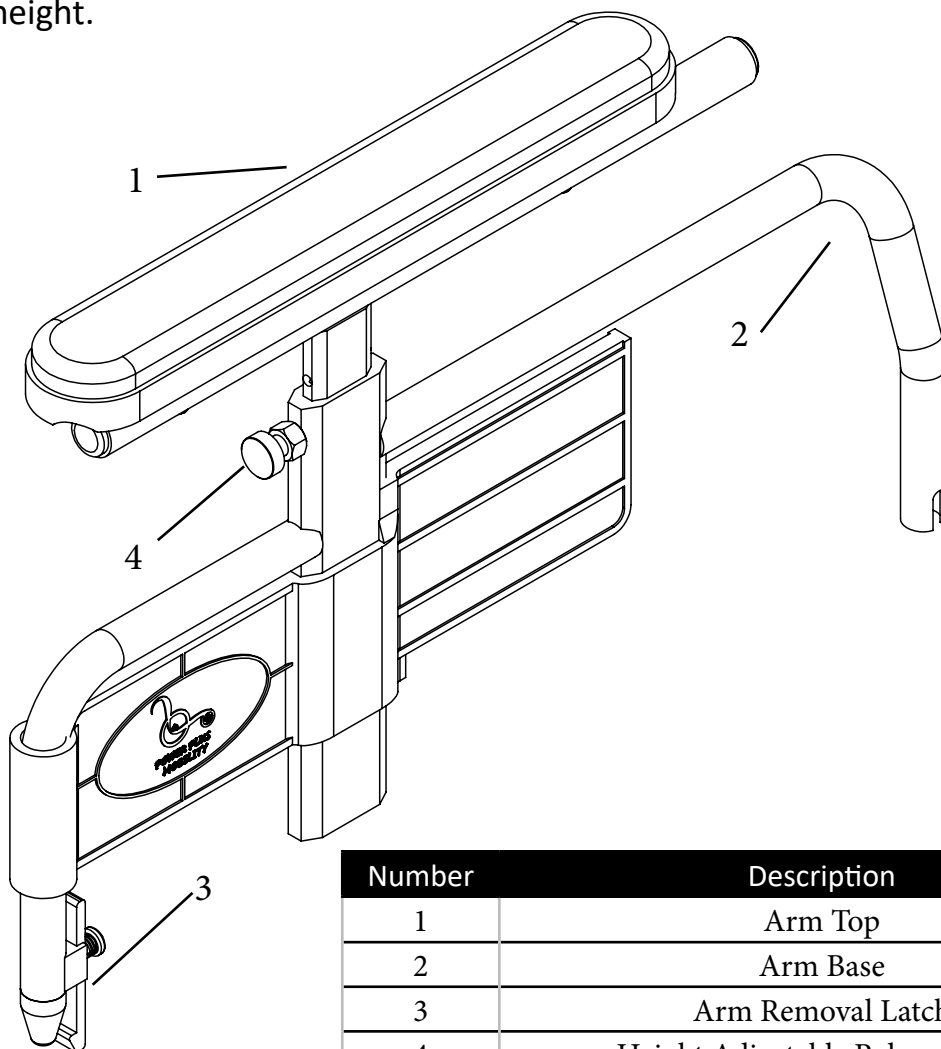

Number	Description	Quantity
1	Arm Top	2
2	Arm Base	2
3	Arm Removal Latch	4
4	Height Adjustable Release Knob	1

Your wheelchair offers an Angle Adjustable Back feature. This feature is only available with T-Arms and allows 5°, 10° or 15° of adjustment.

TO ADJUST BACK ANGLE:

X – Angle Adjustable Bracket

Y – ¼" x 20 x 1¾" Hex Bolt

Y through A on X equals to 90°

Y through B on X equals to 95°

Y through C on X equals to 100°

Y through D on X equals to 105°

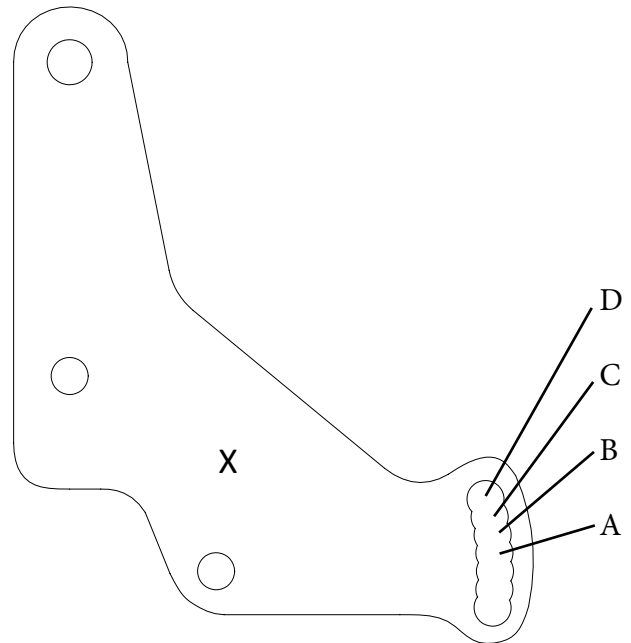
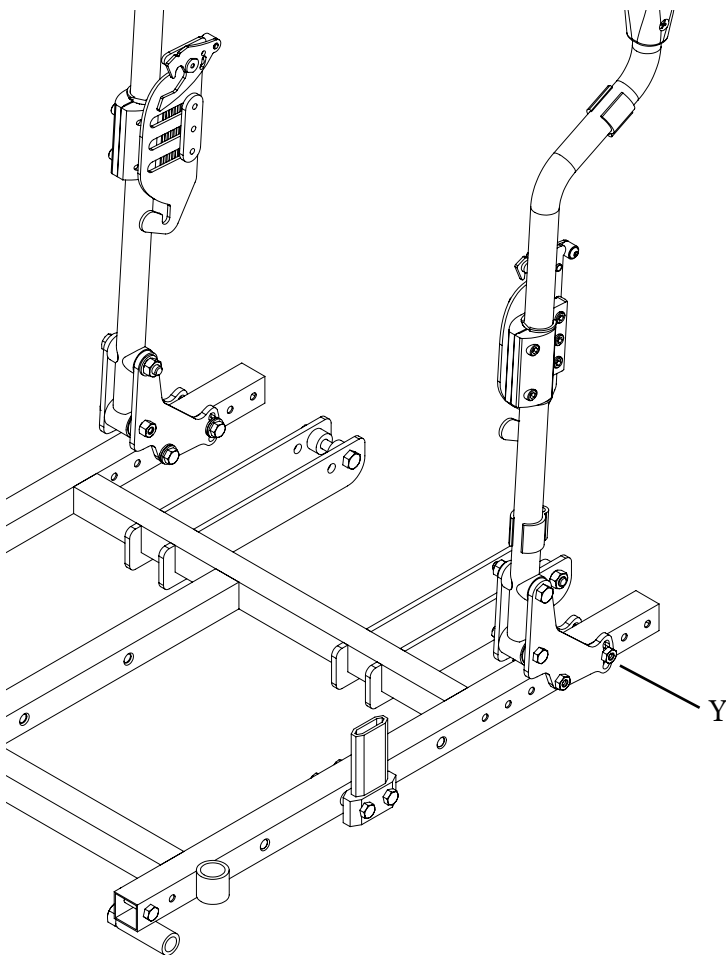

Your wheels are made of injection molded nylon and will not rust. They are also fitted with sealed precision bearings (7) which require no lubrication. However they may need occasional adjustments, due to wear under normal use. Too much side play or looseness or squeaking from your wheel means it needs to be checked. In most cases, tightening of the axle bolt (2) will rectify this condition. Should squeaking or looseness continue to exist after adjustment, the bearings might have to be changed. See your servicing dealer for assistance.

**TO ADJUST REAR WHEELS:**

Remove hub cap (6) to access the axle bolt (2), then simply loosen and remove the axle bolt (2). This allows you to remove the rear wheel. To adjust your seat height, the axle receiver (3) and the axle receiver nut (5) needs to be loosen and removed. Once you select your desired seat height, place the axle receiver (3) and the receiver nut (5) in the corresponding position on the axle plate (4). Tighten the axle receiver (3) and axle receiver nut (5) securely back on the axle plate (4). Place the axle bolt (2) through the rear wheel and tighten back to the axle receiver (3). Then place the hub cap (6) on to protect the axle bolt (2).

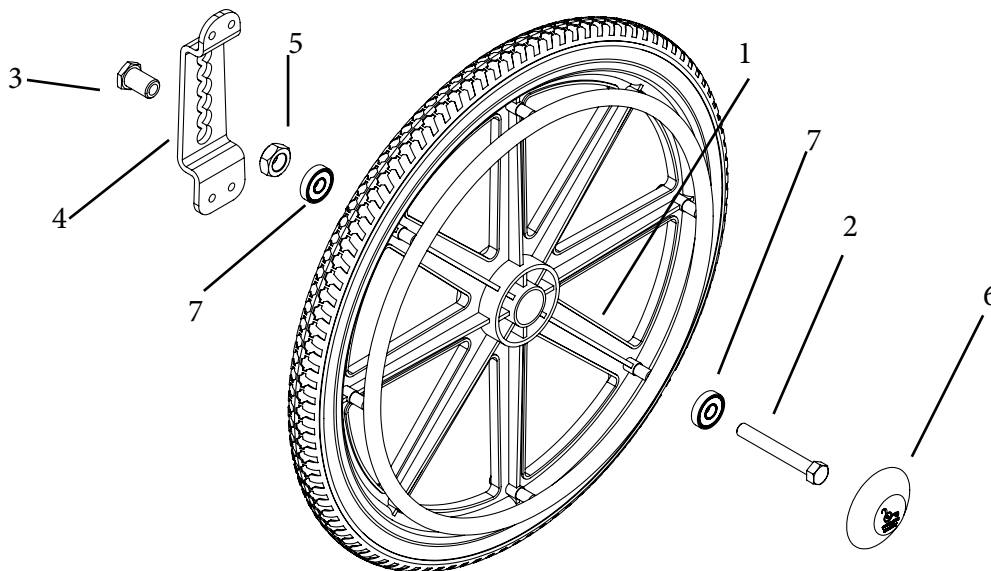

Number	Description	Quantity
1	Wheel	2
2	Axle Bolt	2
3	Axle Receiver	2
4	Axle Plate	2
5	Axle Receiver Nut	2
6	Hub Cap	2
7	Precision Bearing	4

Your casters are made of injection molded nylon and will not rust. They are also fitted with sealed precision bearings (10) which require no lubrication.

If fluttering or pulling is experienced, your stem bearings (9) may need adjustment or replacements. To adjust flip chair back onto its push handle and remove the dust caps (1) on the caster sockets. Tighten the fork stem nut (2) clockwise while holding the caster assembly. Check for smooth easy turning without side or end plays while adjusting, do not over tighten as this may damage the bearings.

Axle adjustment on the caster bearings, although not critical, may also improve the performance. The axle nut should be adjusted to produce a smooth free running caster without side play. Again do not over tighten as this will damage the bearings.

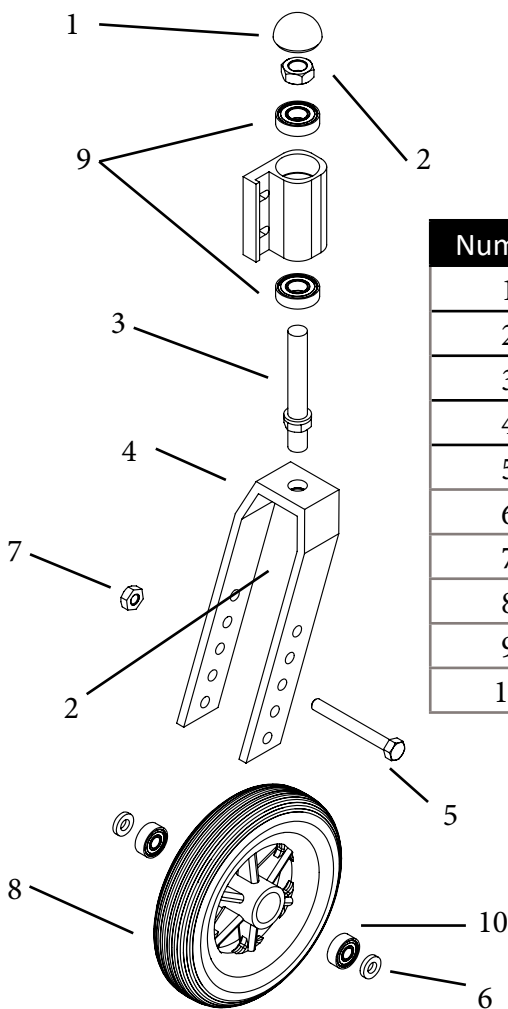

Number	Description	Quantity
1	Dust Cap	2
2	½" Lock Nut	4
3	Fork Stem	2
4	Caster Fork	2
5	5/16" x 2 ¾" Bolt	2
6	5/16" x 1/8" Plastic Washer	4
7	5/16" Lock Nut Thin	2
8	Caster	2
9	Stem Bearing	4
10	Sealed Bearing	4

Your wheelchair allows for many different seat heights. Following the chart below will allow you to properly achieve your desired Seat Height. When adjusting your seat height, always remember to square your front casters back to 90°.

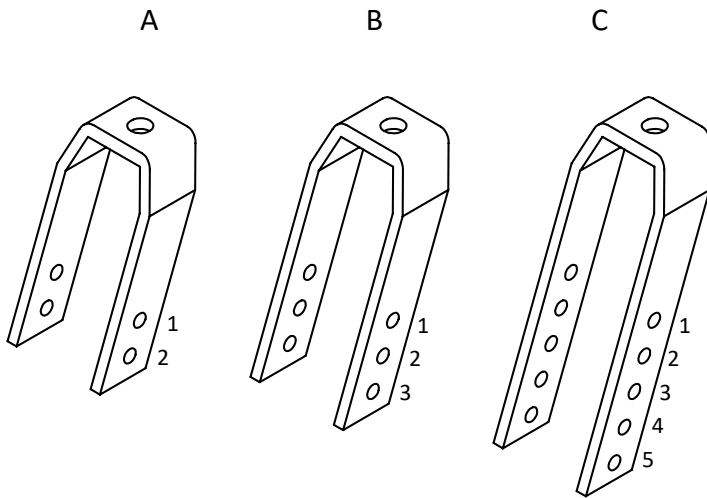

fig.1 - Casters

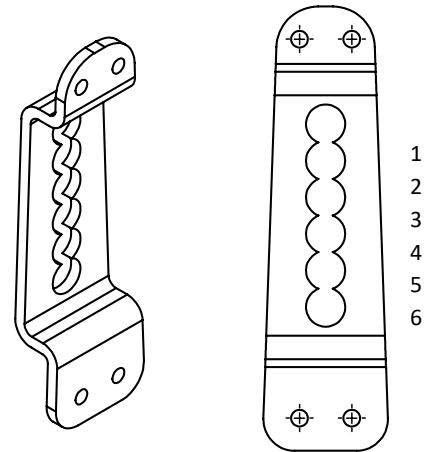

fig.2 - Axle

STF	Rear Wheel	Caster	Fork (fig.1)	Fork Hole (fig.1)	Axle Hole (fig.2)
12.50"	20"	5"	A	2	3
13.25"	20"	6"	A	1	4
14.50"	22"	6"	B	2	4
15.25"	22"	6"	B or C	3	5
16.00"	22"	6"	C	5	6
16.00"	22"	8"	C	4	6
16.75"	24"	8"	C	4	6
17.50"	24"	8"	C	5	6
18.25	24"	8"	C	3	5



TIRES

The standard tires on your chair are solid, maintenance free urethane. These tires are reliable, long lasting and provide a very comfortable ride. However, if your chair is equipped with pneumatic tires, they must be regularly checked for wear and proper inflation. Air pressure should not exceed 40psi. Remember heated air expands, and a wheel with 40psi in cold weather will greatly increase outdoors or in the trunk of a car in the hot sun.

WHEEL LOCKS

The position of the wheel lock is pre-set at the factory to provide you with the safest performance. However, with tire and brake shoe (3) wear, they may have to be occasionally adjusted to ensure safety.

TO ADJUST WHEEL LOCKS:

Loosen the bracket bolt (5) and slide brake assembly (2) towards wheel. Ensure that the brake holds securely but does not require too much effort to be applied. Then tighten the bracket bolt, securing assembly at the appropriate position. Although lubrication is not necessary, a light application can enhance performance.

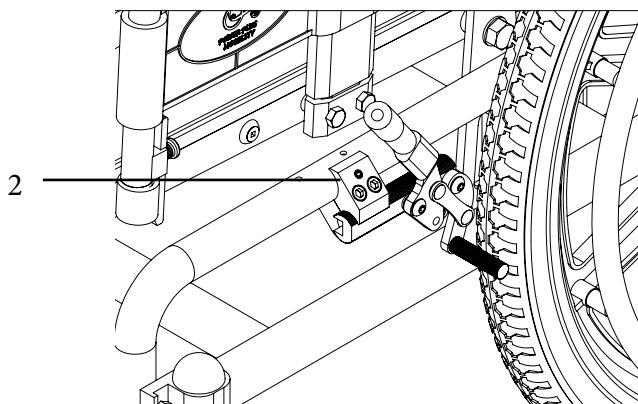
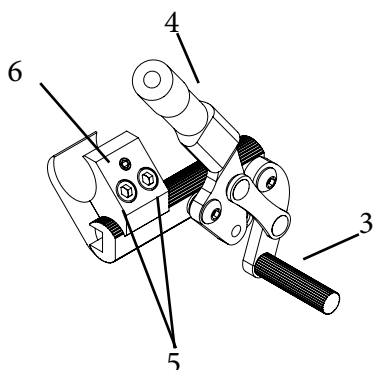

Number	Description	Quantity
1	Tires	2
2	Bracket Bolt	2
3	Brake Shoe	2
4	Brake Handle	2
5	Bracket Bolt	4
6	Bracket Bolt Key	2

1

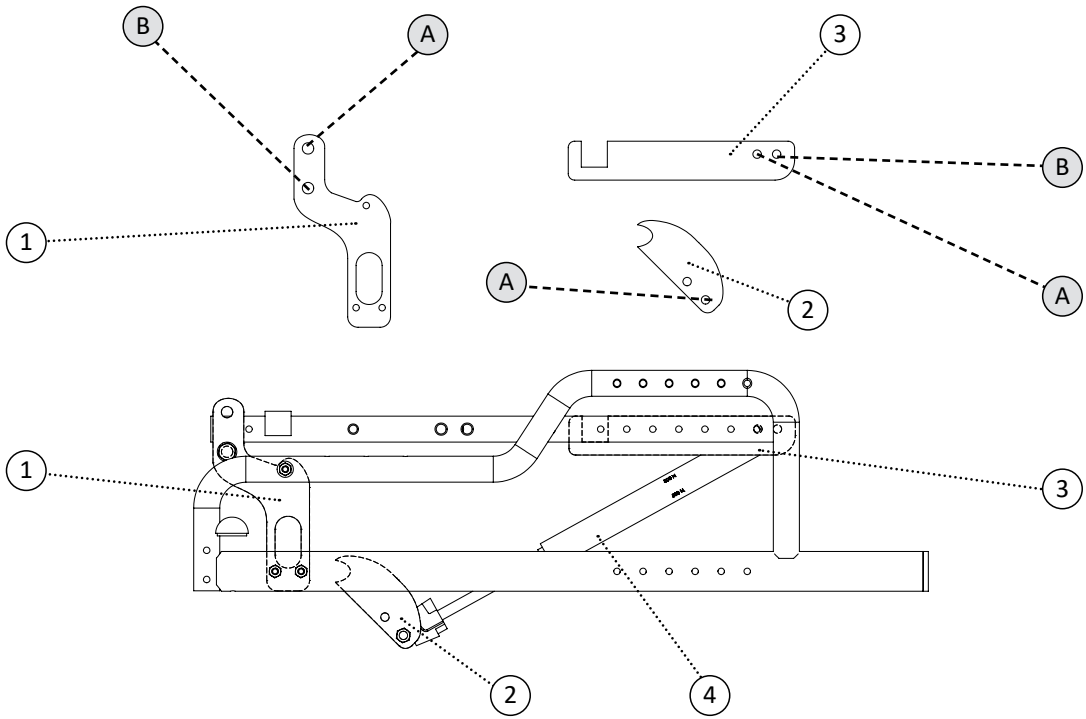

#	Description	Quantity
1	Front Pivot Bracket	2
2	Lower Frame Cylinder Mount Bracket (Front)	4
3	Upper Frame Cylinder Mount Bracket (Rear)	4
4	Gas Spring Cylinder	2

Setting	Frame Bracket	Cylinder Mount
Standard	1A	2A/3A (Right Cylinder 400N, Left Cylinder 400N)
Low	1B	2A/3B (Right Cylinder 400N, Left Cylinder 400N)

Weight Setup
0-250 lbs: 2 x 400N
250+ lbs: 2 x 550N



# EXTREME USER MANUAL



POWERPLUSMOBILITY.COM  
50 Malcolm Road | Guelph, ON | Canada N1K 1A9  
Telephone (519)-763-9976 | Fax (519)-837-1832