

**THIS TECHNICAL MANUAL HAS BEEN DEVELOPED FOR AND
INTENDED TO BE USED BY A QUALIFIED TECHNICIAN
WORKING FOR AN AUTHORIZED KI MOBILITY DEALER.**

ROGUE ALX
&
Little Wave XP

TECHNICAL
MANUAL



WARNING

WARNING: Repairs and adjustments not made by a qualified technician working for an authorized Ki Mobility Dealer can result in poor performance or failure of the device which may cause serious injury or death.

This technical manual is designed to aid in the different procedures that may be needed for the Rogue ALX and Little Wave wheelchairs. This technical manual does not replace, but aids the user instruction manual, adjustment guides and instructions. The procedures shown in this technical manual should only be performed by an Assistive Technology Practitioner (ATP) or clinical professional trained to do wheelchair repairs, adjustments and retrofits.

Additional information can be found in the Rogue ALX and Little Wave User Instruction Manuals. The user instruction manuals can be found on the Ki Mobility website.

If you have any questions or concerns about any aspect of this wheelchair, this manual, or the service provided by us or your retail supplier, please do not hesitate to contact us by telephone at:

715-254-0991

In writing at:

Ki Mobility
5201 Woodward Drive
Stevens Point, WI 54481
U.S.A

Via email at:

sales@kimobility.com

Or via our Authorized EU Representative:

Etac Supply Center AB
Långatan 12
33233 Anderstorp
Sweden

Table of Contents

Tools.....	3
Frame Tube Size Guide.....	3
Spoke Tension Values.....	3
Chair Measurement References.....	4
Caster Mount	5
Caster Forks and Stems	6
Caster Angle and Squaring	11
Camber Mount Assembly - Rogue ALX.....	12
Camber Mount Assembly - Little Wave	16
Camber Tube and Adapters.....	18
Center of Gravity Adjustment.....	19
Setting Toe to Zero	20
Backrest Assembly	21
Height Adjustable Back Post	25
Fixed Height Back Post	26
Rigid Stroller Handle	27
Ergo Stroller Handle.....	27
Bolt-On Push Handle	28
Height Adjustable T-Arm.....	29
Angle Adj. Locking Flip Up Extendable Armrest - Available on Little Wave ...	30
Swing Away Armrest.....	31
Cane and Crutch Holder	32
Luggage Carrier	33
Handrim Configurations	34
Handrim Construction.....	35
Seat Pan.....	36
Seat Upholstery.....	37
Side Guards	38
Transit	42
Angle Adjustable Footrest.....	44
Angle Adjustable Flip Under Footrest	45
High Mount Angle Adjustable Footrest - Available on Rogue ALX.....	46
High Mount Angle Adj. Footrest (10"-14" Wide).....	47
High Mount Angle Adjustable Footrest (15" - 19" Wide)	48
High Mount Angle Adjustable Flip Under Footrest	49
Little Wave Frame Width.....	50
Anti-Tips.....	51
Little Wave 5th Wheel	53
Wheel Locks.....	56
Drum Brake	58
Caster Flutter	61

Tools

Please see the list below to identify the tools needed throughout this tech manual. Always check tools to ensure the ends are not stripped and that the tool can perform its function properly without damaging any parts or hardware on the chair.

Tools Needed		
• 2.5mm Allen Wrench	• Two 8mm Wrenches	• 6mm Allen Wrench
• 3mm Allen Wrench	• Two 10mm Wrenches	• Utility blade
• 4mm Allen Wrench	• 13mm Wrench	• Torque Wrench
• 5mm Allen Wrench	• 17mm Wrench	• 24mm Wrench
• 5.5mm Allen Wrench	• 19mm Wrench	• Phillips Screwdriver

Frame Tube Size Guide

Tubing sizes subject to change without notice

This information is a reference for situations where the tube sizes are needed for certain attachments.

Rogue ALX / Little Wave
Frame Tube
Frame Tube: 1 3/8"
Camber Tube: 1 1/8"
Back Canes
Fixed Height Back Canes: 1"
Rigidizer Bar: 7/8"
Lower Height Adjustable Back Tube: 1"
Upper Adjustable Upper Back Tube: 3/4"
Arms
Swing Away: 1"
Upper T-Arm: 7/8"
Transfer Tube T-Arm: 3/4"
Angle Adjustable Flip Up: 1"
Footrests
Footrest Tubes: 3/4"

Spoke Tension Values

OAD Spoke	60-100 kgf
Drum brake Spoke	90-120 kgf radial side / 60-90 kgf crossed side
Maxx Spoke	60-100 kgf
Low Cost Spoke	60-100 kgf
Spinergy	Contact Spinergy for more information

Chair Measurement References

The Rogue ALX and Little Wave wheelchairs are capable of many adjustments to configure the chair to the user's needs. See the diagram below for terms that are commonly used during the process of adjusting the chairs.

A. Seat Width (see diagram 1)

Measured from outside of frame tube on one side to the outside of frame tube on the other side.

B. Seat Depth (see diagram 3)

Measured from front of back posts to front edge of seat sling. Seat sling starts at beginning of bend at front of frame.

C. Sling Position (see diagram 2)

In Performance Position (0°), sling is at front of frame to keep chair shorter and more maneuverable. The 1" or 2" seat sling position extends the frame in front of the sling by that amount. Adding more frame can improve stability and provide support to aid in transfers.

D. Front Frame Bend (see diagram 3)

Angle between front seat tube and ground.

E. Footrest Taper (see diagram 1)

Indicates bend of front frame creating footrest. Taper is measured from outside of seat frame to outside of front tube.

F. Front Seat Height (see diagram 1)

Measured from floor to top of seat tube at front of seat sling.

G. Footrest Width (see diagram 1)

Measured from inside of front tube to inside of front tube on other side. Footrest width is listed below for each seat width and taper.

Seat Width	Straight	1" Taper	2" Taper
Outside Measurement	2" Narrower than Seat Width	4" Narrower than Seat Width	6" Narrower than Seat Width
12"	9.5"	7.5"	
13"	10.5"	8.5"	
14"	11.5"	9.5"	
15"	12.5"	10.5"	
16"	13.5"	11.5"	9.5"
17"	14.5"	12.5"	10.5"
18"	15.5"	13.5"	11.5"
19"	16.5"	14.5"	12.5"
20"	17.5"	15.5"	13.5"

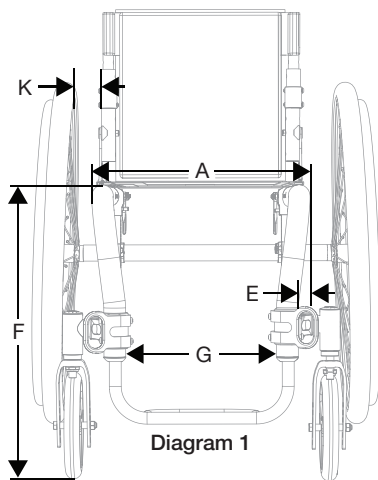

Diagram 1

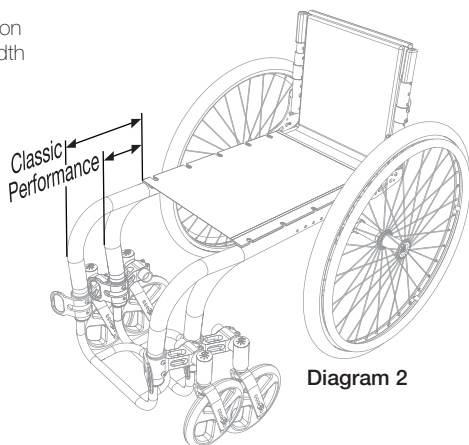

Diagram 2

H. Seat to Footrest Length (see diagram 3)

Measured from front edge of seat sling to top rear of footrest. Footrest length of at least 2.5" shorter than front seat height recommended.

I. Rear Seat Height (see diagram 3)

Measured from floor to top of seat tube at front of back post. Rear seat height is custom to needs.

J. Center of Gravity Preset (see diagram 3)

Measured from front of back post to center of rear axle. 0° indicates axle will be directly under back post.

K. Rear Wheel Spacing (see diagram 1)

Measured from outside of seat back to inside of rear tire. Adjustable out .5" from setting.

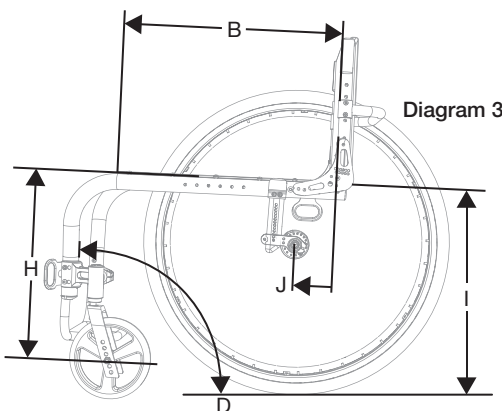

Diagram 3

Caster Mount

NOTE: The footrest tube must be removed prior to installation to allow the caster mount to slide onto the chair frame.

1. Install the two end caps (G & I) and two bearings (J) into the caster housing (H).
2. Install the caster housing assembly into the caster mount (B) and secure with three bolts (E & F) using a 4mm Allen wrench.
3. Install the caster mount assembly onto the chair frame and secure by installing the four bolts (A, C & D) through the caster mount and chair frame holes using a 4mm and a 5mm Allen wrench.

NOTE: There are three different sizes of the caster housing available - standard, extended and tall. Caster housing size is dependent on caster size, front seat height and footplate selection. If additional help is needed regarding caster housing size please contact Ki Mobility customer service.

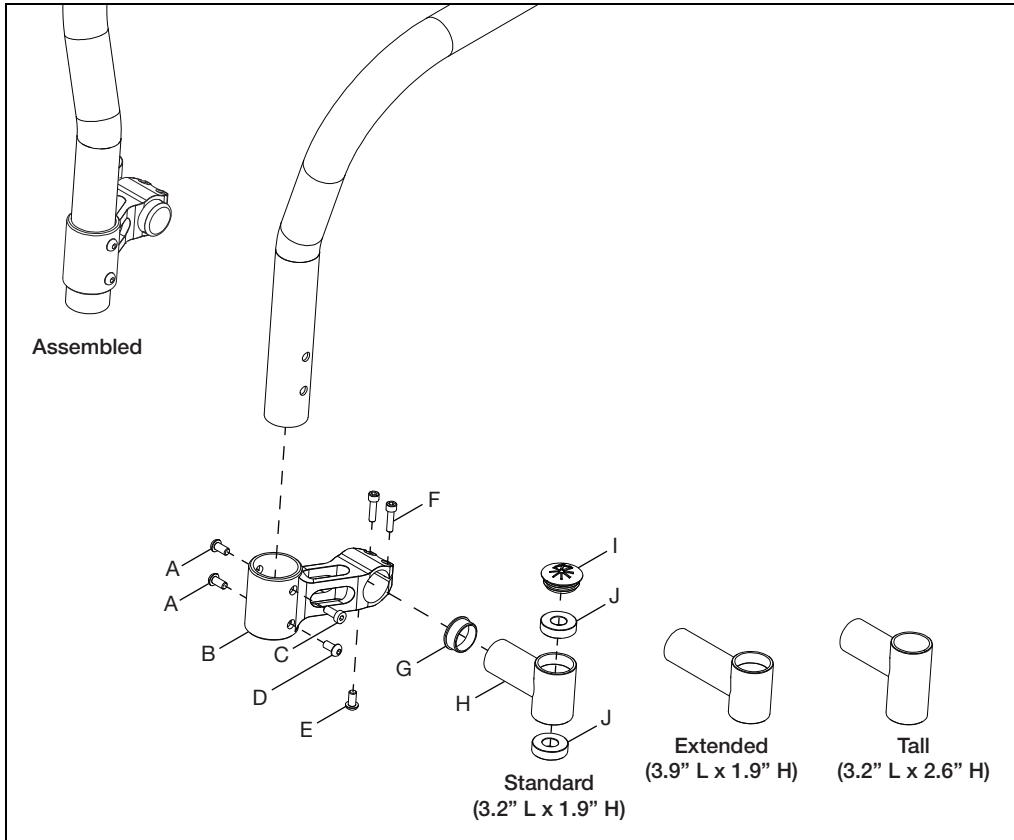

Caster Forks and Stems

NOTE: Different configurations achieve the desired front seat height based on caster size. If making a change to front seat height or caster size, the combination of fork and stems could vary.

1. Install stem (A) into fork (B) with washer (C) and nut (D) using a 16mm wrench.
2. Install caster wheel (H) into fork (D) with two screws (E), a threaded barrel (F) and two spacers (G) using two 4mm Allen wrenches.

NOTE: There are two sizes of caster stems (standard and +3/4") and three sizes of slotted forks (short, standard and tall) and standard forks (4", 5" and 6") that can be used. The image below shows the stems and forks. The installation process is the same for whichever stem and fork you use.

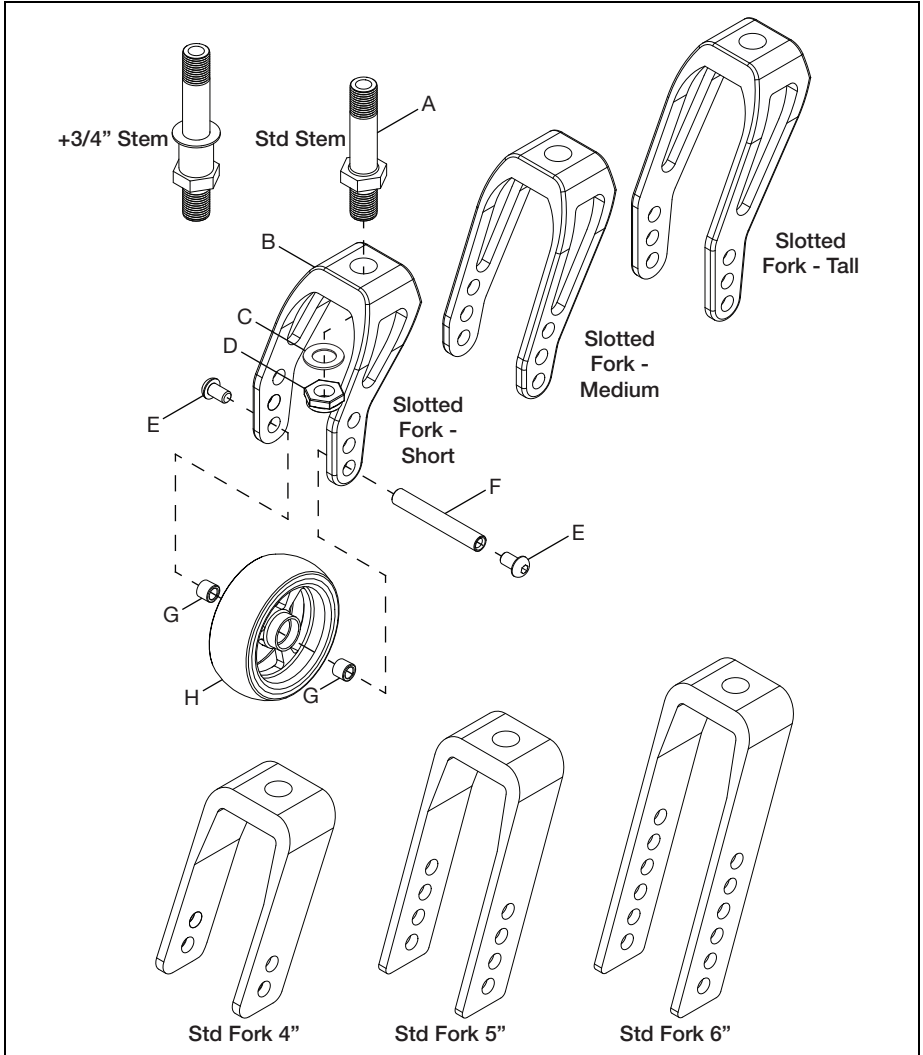

Caster Forks and Stems

Single Sided Fork

1. Install stem (A) into single sided fork (C) with washer (B) and nut (D) using a ½" wrench.
2. Install caster wheel (G) onto fork (C) with two screws (E) and the axle shaft (F).

NOTE: There are three sizes of caster stems (standard, +3/4" and +1") that can be used. The installation process is the same for whichever stem and fork you use.

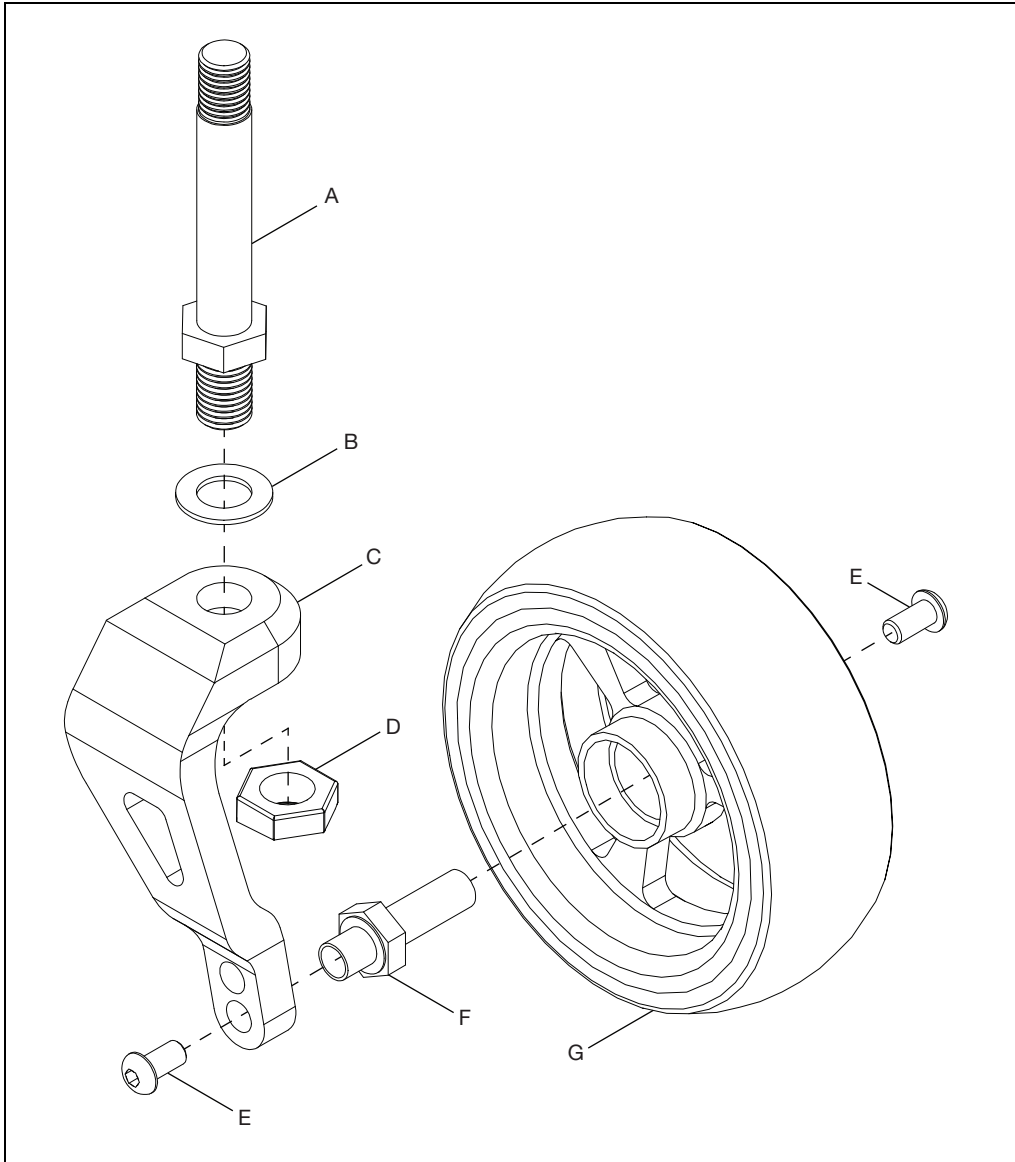

Caster Forks and Stems

Frog Legs Ultra Sport Fork Assembly

1. Install Frog Leg Ultra Sport Fork (A) onto caster wheel (E) with axle (B), screw (C) and two spacers (D) using two 4mm Allen wrenches.

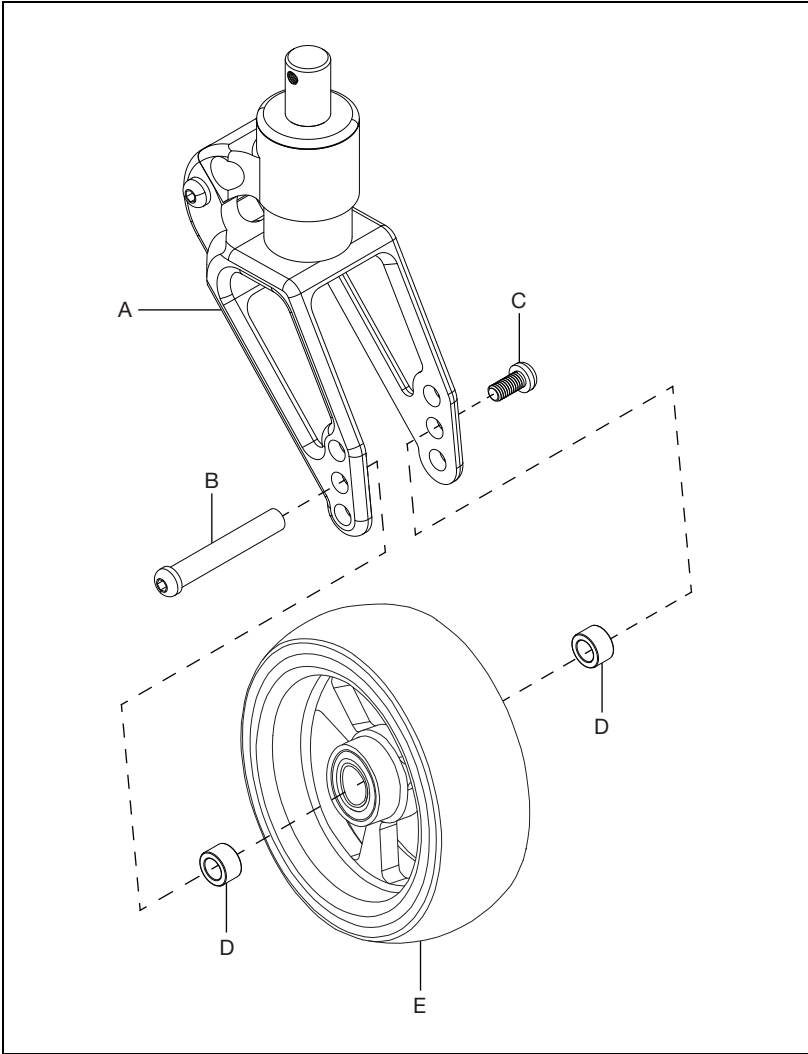

Caster Forks and Stems

Frog Legs Phase 2 Carbon Fork Assembly

1. Install Frog Leg Phase 2 Carbon Fork (A) onto caster wheel (E) with axle (B), screw (C) and two spacers (D) using two 4mm Allen wrenches.

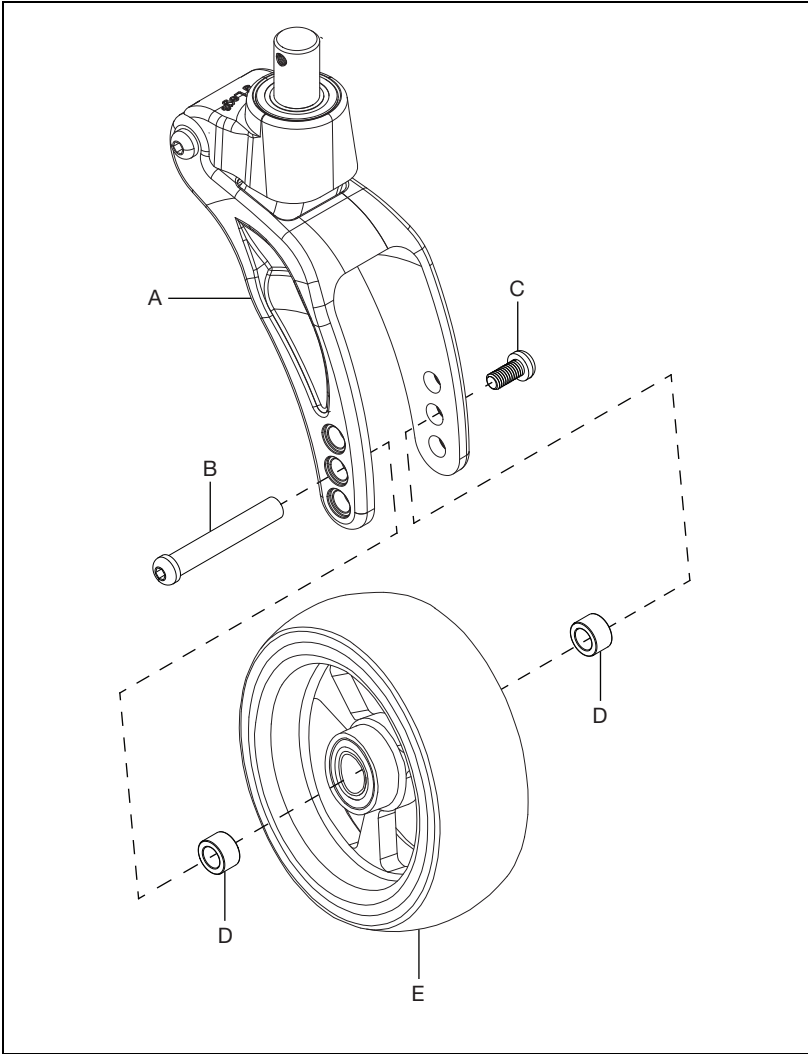

Caster Forks and Stems

Frog Legs Ultra Sport Fork Polymer Replacement

NOTE: The Ultra Sport fork has different polymers that can be used based on the chair user's weight and preferred ride. The Phase 2 fork has one polymer that works for any configuration. If ever needed, the replacement procedure is the same for a Phase 2, but no coin is needed.

1. Remove the pivot pin screw (D) using a 4mm Allen wrench.
2. Use a punch or small screwdriver and a rubber mallet to push the pivot pin (A) out.
3. Open the fork assembly and remove the polymer (C) and coin (B).
4. Install the new polymer (C) and coin (B).
5. Insert the pivot pin (A) back into the fork assembly. A punch or small screwdriver can be used to help align holes if needed.
6. Secure the assembly by reinstalling the pivot pin screw (D) using a 4mm Allen wrench.
7. Repeat steps on opposite side.

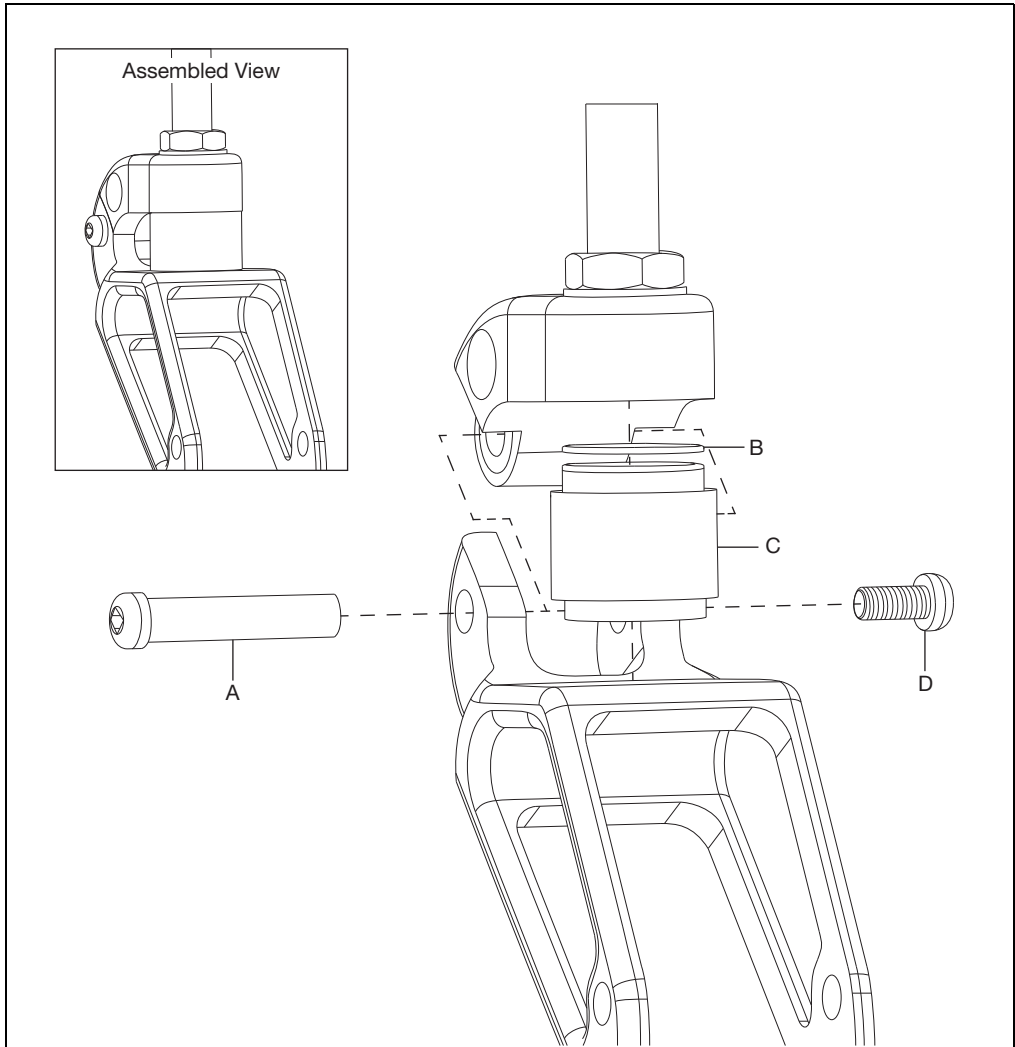

Caster Angle and Squaring

To maintain optimal performance of your Rogue ALX and Little Wave, the front caster housing should always be aligned perpendicular to the ground. Your chair is shipped aligned. It is recommended that caster squareness is checked after making adjustments to the chair configuration related to any of the following items: caster size or type, camber, rear wheel, tire, center of gravity and seat heights. Caster squareness should always be the last check made prior to use after adjustments or changes to the chair have been made.

After all other adjustments are made you should check your caster housing alignment and realign if the housing is not perpendicular to the ground.

NOTE: A hole has been drilled in the caster housing to ensure squareness. This hole helps keep the caster square, but it does allow adjustment of up to 4° in the case that the caster needs to be resquared. See instructions below.

Adjusting the Caster Angle:

For optimum performance, the caster housing should always be at 90° angle to the floor (perpendicular to the ground).

1. To change the angle, place the chair on a flat surface (such as a table).
2. Loosen the two 5mm Allen screws on the top of the caster housing clamp. This will allow the caster pivot tube to rotate freely (A).
3. Loosen the one screw (B) underneath the housing clamp using a 4mm Allen wrench.
4. Place a large right triangle against the table surface and the front surface of the caster bearing housing. This will align the caster stem rotational axis perpendicular to the floor surface.
5. When the alignment is correct, retighten the two 5mm retaining screws to 80 in/lbs.
6. Tighten screws in a balanced fashion - tighten one screw to 50 in/lbs and then the second to 50 in/lbs. Return to the first screw and tighten to 80 in/lbs and then tighten last screw to 80 in/lbs. Repeat on opposite side.
7. Retighten the one screw underneath the housing clamp using a 4mm Allen wrench.

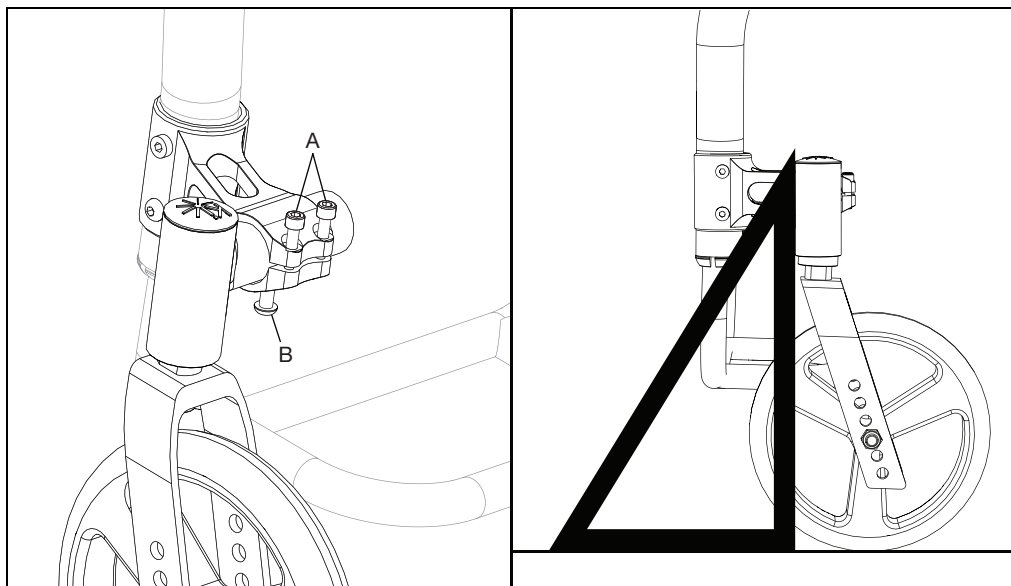

Camber Mount Assembly - Rogue ALX

Standard Tower Index Mount

1. Install the camber mount clamp (A) onto the camber tube and secure with two bolts (B) and the set screw (C) using a 4mm Allen wrench and a 2.5mm Allen wrench.

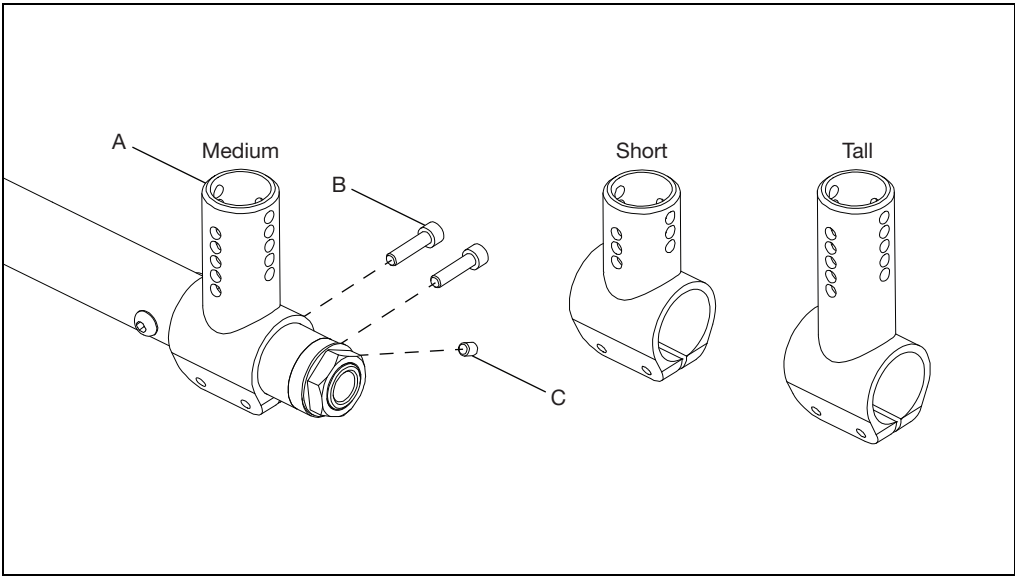

2. Install the camber mount (B) onto the camber mount clamp and secure with two bolts (C), two washers (D) and two nuts (A) using a 4mm Allen wrench and an 8mm wrench.

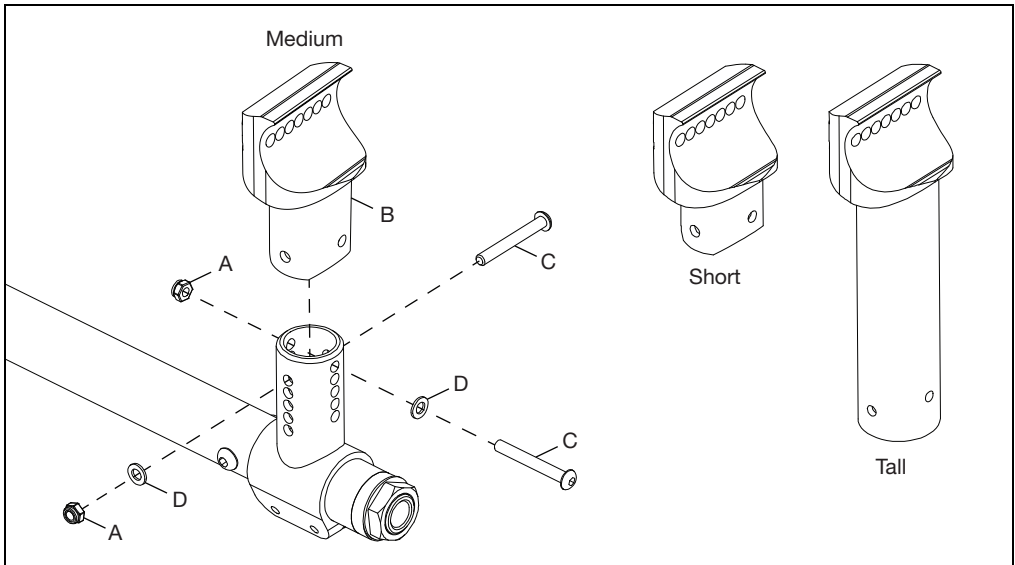

Camber Mount Assembly - Rogue ALX

3. Install camber mount and camber tube assembly onto the frame with three bolts (B) and three nuts (A) using a 5mm Allen wrench and a 10mm wrench. The hardware used to attach the camber mount to the frame is also used to attach the back plate.

NOTE: The holes used for mounting the camber mount and the back plate set the seat depth. Use the holes that provide the desired seat depth.

NOTE: One long bolt (65mm) and one oval top nut are used in the attaching of the camber mount and back plate. See the image below for the location of those two pieces of hardware.

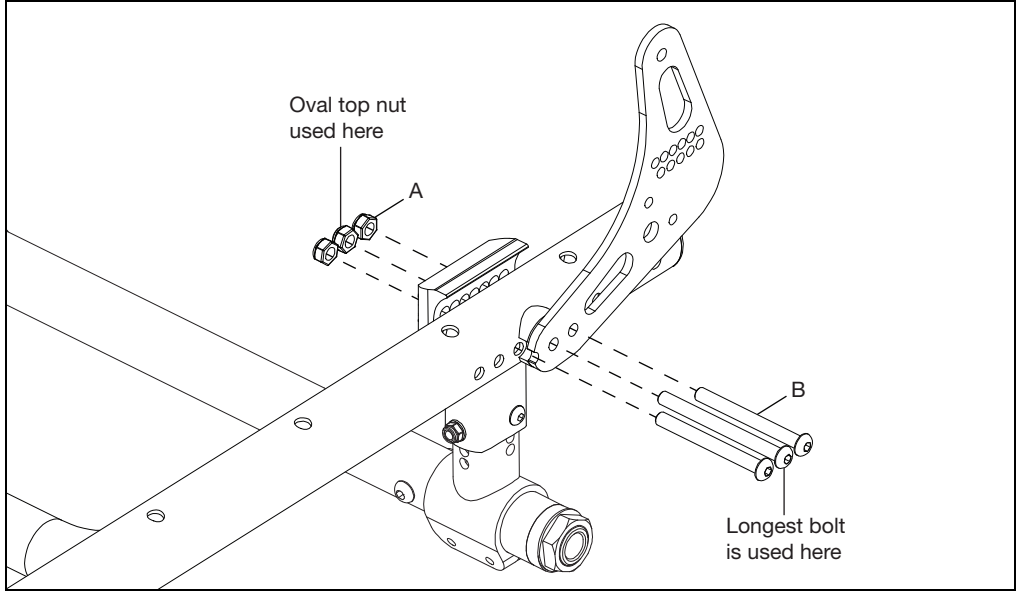

4. Repeat steps on opposite side.

NOTE: Ensure both sides of chair have the camber mount and back plate mounted in the same configuration.

Camber Mount Assembly - Rogue ALX

MX Tower Index Mount

1. Install the camber mount clamp (D) onto the camber tube (A) and secure with two bolts (B) and the set screw (C) using a 4mm Allen wrench and a 2.5mm Allen wrench.

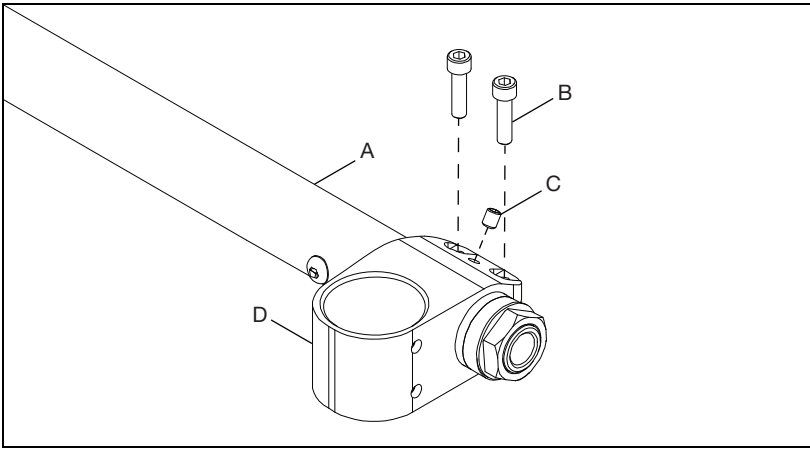

2. Install the camber mount (A) onto the camber mount clamp and secure with two bolts (D) and two nuts (B) using a 4mm Allen wrench and an 8mm wrench. Install the end cap (C) into the camber mount tube.

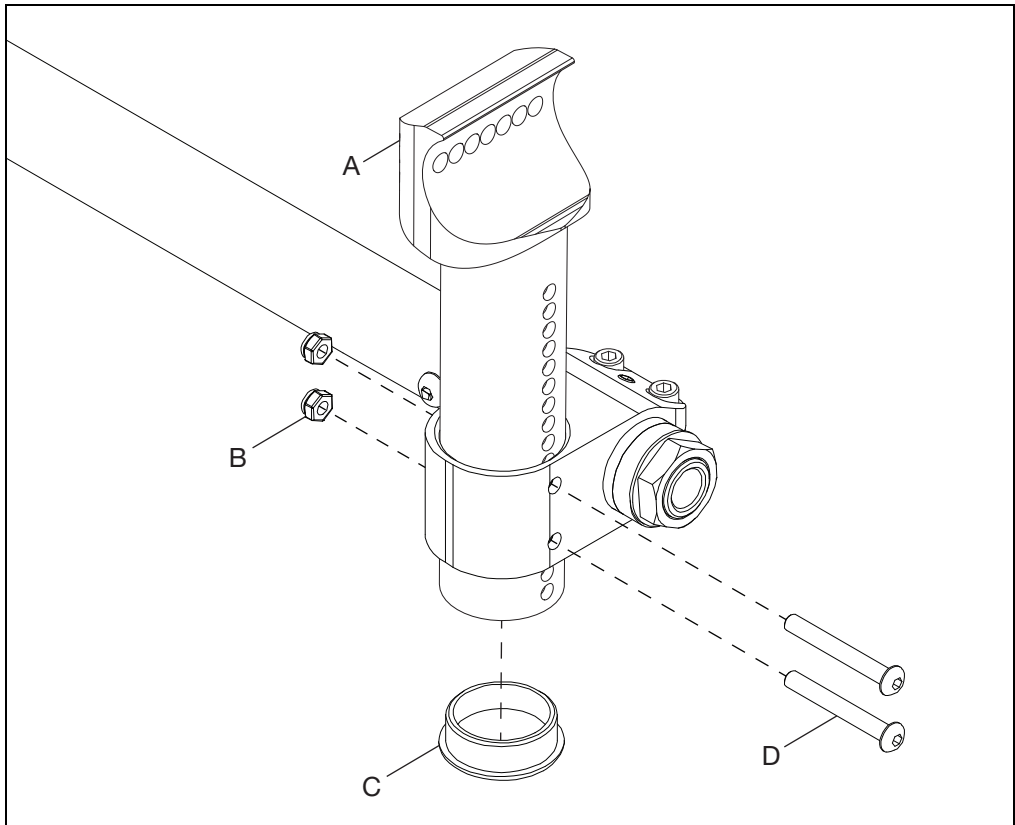

Camber Mount Assembly - Rogue ALX

3. Install camber mount and camber tube assembly onto the frame with three bolts (B) and three nuts (A) using a 5mm Allen wrench and a 10mm wrench. The hardware used to attach the camber mount to the frame is also used to attach the back plate.

NOTE: The holes used for mounting the camber mount and the back plate set the seat depth. Use the holes that provide the desired seat depth.

NOTE: One long bolt (65mm) and one oval top nut are used in the attaching of the camber mount and back plate. See the image below for the location of those two pieces of hardware.

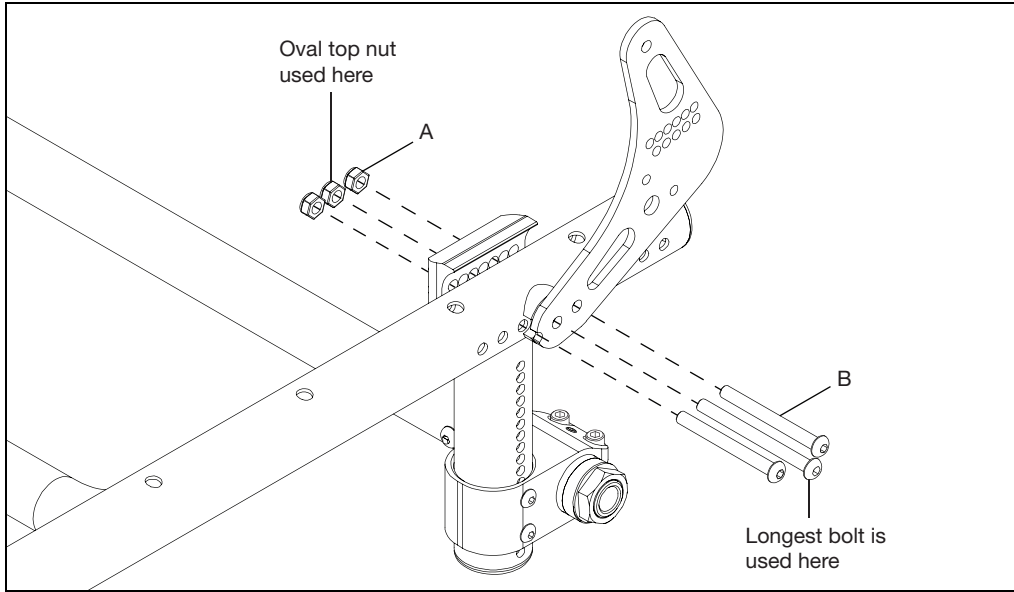

4. Repeat steps on opposite side.

NOTE: Ensure both sides of chair have the camber mount and back plate mounted in the same configuration.

Camber Mount Assembly - Little Wave

NOTE: Install one side at a time so you are able to install the camber tube properly in a later step.

NOTE: The outside clamp (B) is not used when the COG is set at -0.5 or less.

1. Install the tower clamps (B & C) onto the frame with the camber mount tube (E) and the camber tube cap (F) using two screws (A) and two nuts (D) with a 4mm Allen wrench.

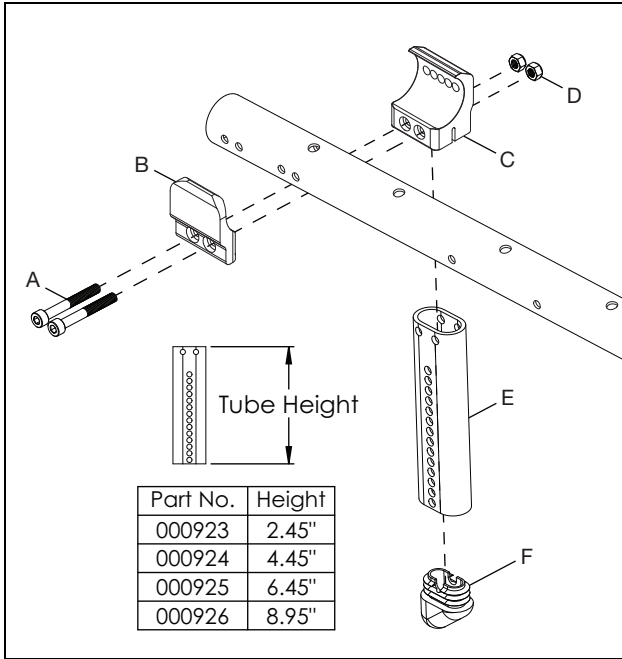

2. Install the camber tube mounting clamp (B) onto the camber mount tube and secure with two screws (A) and two nuts (C) using a 4mm Allen wrench and an 8mm wrench.

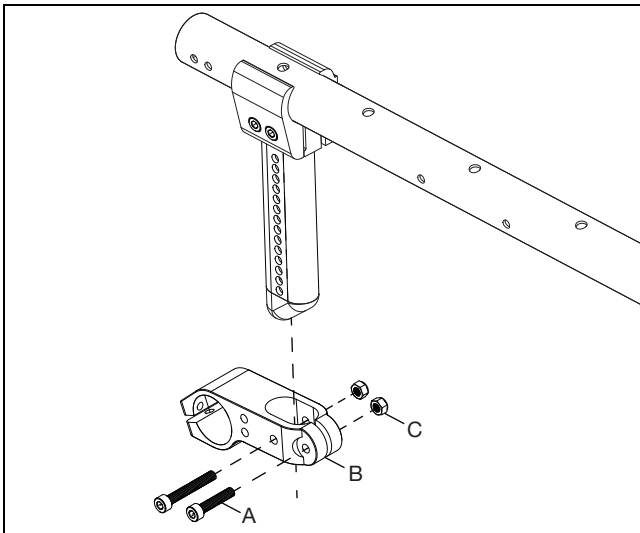

Camber Mount Assembly - Little Wave

3. Install camber tube (D) into the camber tube mounting clamp and secure with screw (B) and nut (C) using a 4mm Allen wrench and an 8mm wrench. Install and tighten the two set screws (A) with a 2.5mm Allen wrench.

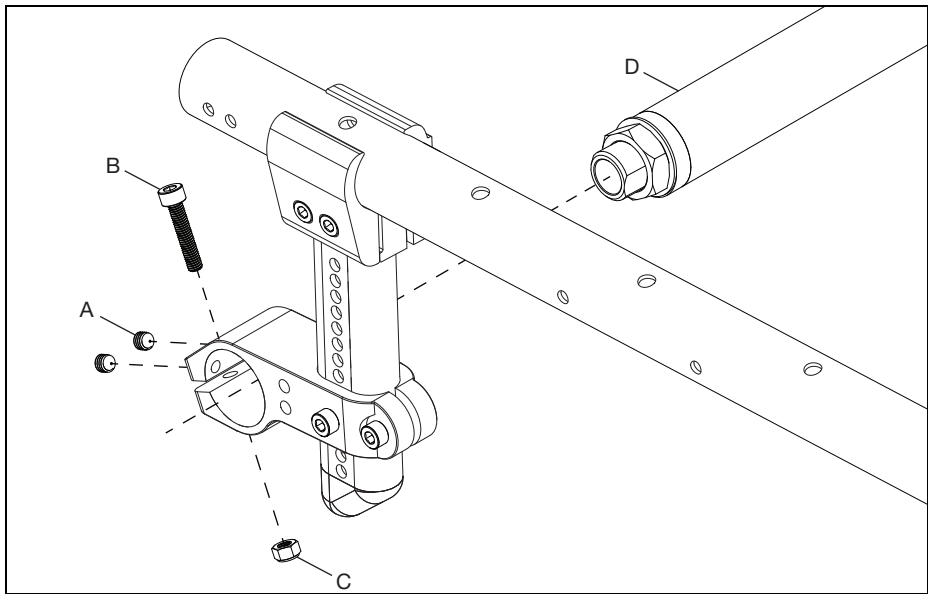

4. Repeat steps on opposite side.

Camber Tube and Adapters

NOTE: The caster squareness and toe-in/toe-out should always be checked anytime a change is made to camber degree.

1. Install axle receiver, axle receiver nut, axle plate washer and camber adapter into the camber tube.

NOTE: The camber adapter is available with 0°, 2°, 4°, 6° and 8° camber.

2. Secure the camber adapter into the camber tube with two screws and a threaded barrel using two 4mm Allen wrenches.

3. Repeat steps 1 and 2 on opposite end of camber tube.

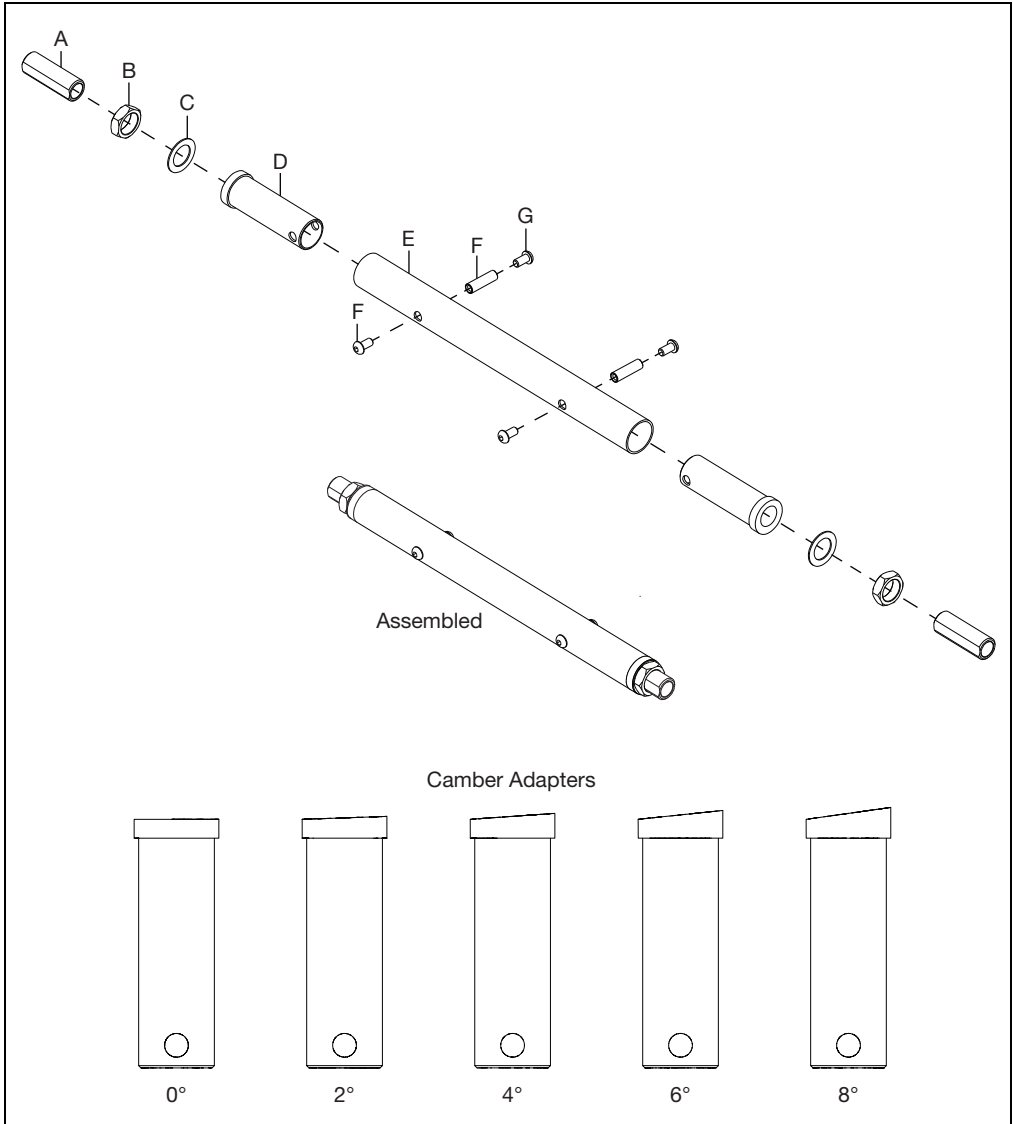

Center of Gravity Adjustment

The most important adjustment on your Rogue ALX or Little Wave wheelchair is the position of the rear axle.

NOTE: Changes to the center of gravity may affect the rear seat height, toe-in/toe-out of the rear wheels and the squareness of the casters. If you change your center of gravity position, readjust all of these settings if necessary.

NOTE: Adjusting the chair's center of gravity will require readjusting the location of the wheel locks (if provided). Adjust the center of gravity by moving the two camber mount clamps (B) forward or rearward on the seat tube (A).

Moving the camber mount clamps forward shortens the wheelbase and lightens the front end, making your chair more maneuverable. Moving the camber mounts rearward makes the chair more stable and less likely to tip over rearward.

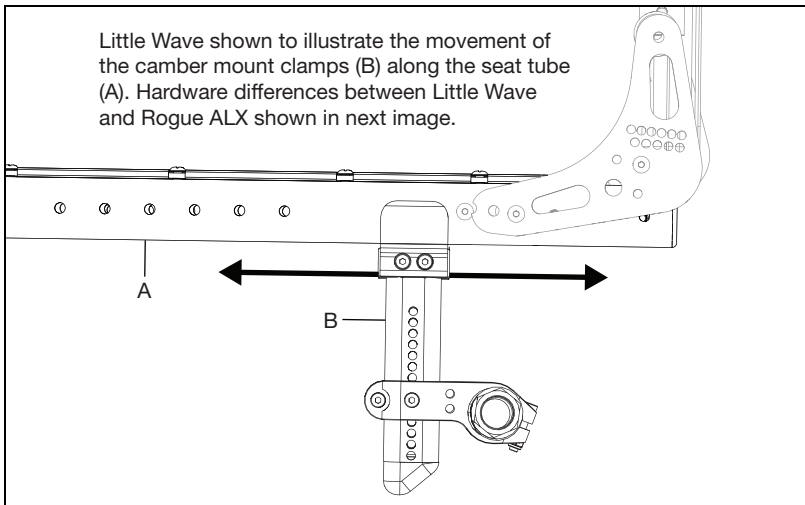

1. To adjust the center of gravity location, remove both rear wheels.
2. Remove the screws (C) and nuts (A) that secure the camber mounts (B) to the seat tubes.
3. Slide the camber mount forward or rearward along the seat tube to the desired hole location. Reinstall screws and nuts. In some cases where the attaching bolts also go through the backrest plate, longer bolts are required (Rogue ALX image below shows an example).
4. Repeat on the other side. Ensure both sides are set in the same configuration.

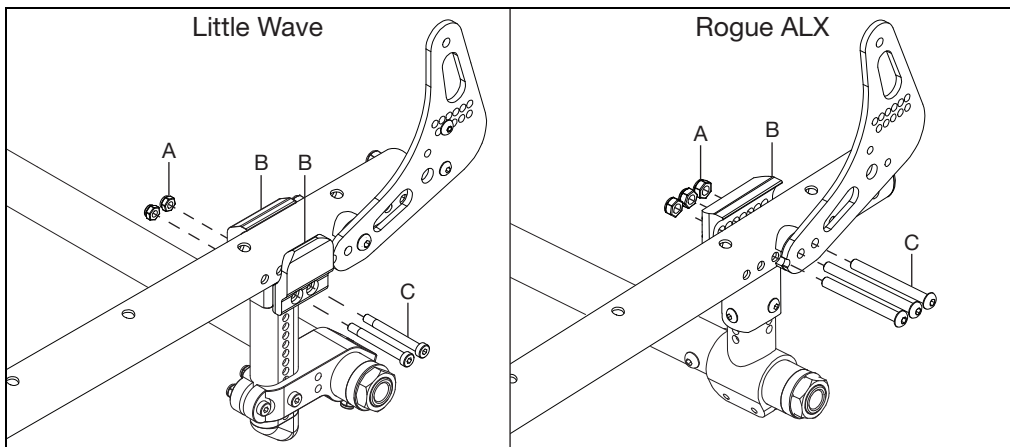

Setting Toe to Zero

NOTE: A wheelchair equipped with 0° camber plugs cannot have a toe-in-toe-out condition. This adjustment is only required when using 2°, 4°, 6° and 8° camber adapters.

Toe refers to how well the rear wheels of the chair are aligned relative to the ground. It affects how well the chair will roll. Drag or rolling resistance is optimally minimized when the wheel toe is set to zero.

Setting the toe to zero:

1. Loosen the four cap screws (A) (2 per side) that secure the camber tube clamp.
2. Rotate the camber tube (B) until the screws (C) that secure the camber spuds are level with the ground. The toe is now set at zero.
3. Before tightening the screws (A), make certain that the camber tube is centered left-to-right relative to the wheelchair frame. There should be an equal gap on both sides or none at all.
4. Tighten screws in a balanced fashion - tighten one screw to 50 in/lbs and then the second to 50 in/lbs. Return to the first screw and tighten to 80 in/lbs and then return to the second screw and tighten to 80 in/lbs. Repeat on opposite side.

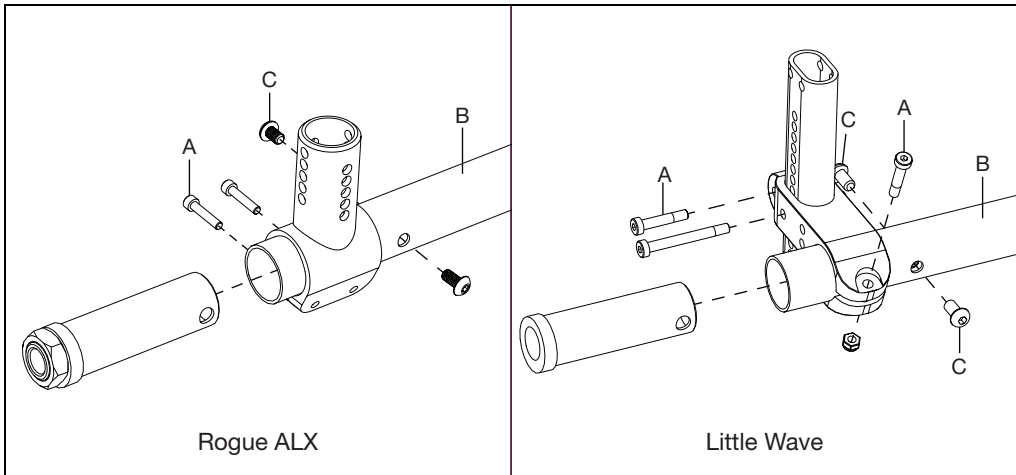

Backrest Assembly

Backrest Installation

NOTE: Remove existing backrest before beginning the installation process.

NOTE: If replacing the whole backrest, the backrest will come as an assembly and the first two steps can be skipped.

1. Install the release lever assembly (B) onto the back post (A) with a screw (D) and nut (C) using a 3mm Allen wrench. The screw will pass through the tube sleeve (E) and release pin (G) which are installed up through the bottom of the back post. The compression spring (F) is installed up through the bottom of the back post also, but the bolt doesn't pass through it. Repeat steps on opposite side of back post.

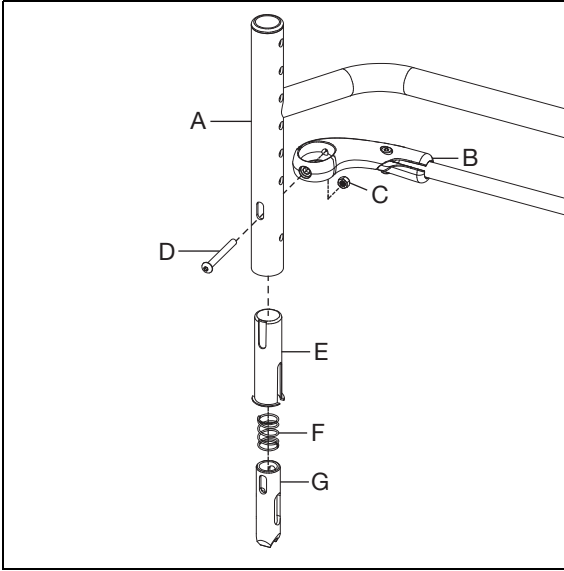

2. Secure the relax bumper (C) to the relax saddle (B) with the screw (A) using a 3mm Allen wrench. There are three index slots that the screw can be installed in - the top (9°), middle (4.5°) and bottom (0°). Install the screw in the desired position and repeat steps on the second set of saddles and bumpers. Ensure both sides are set in the same position.

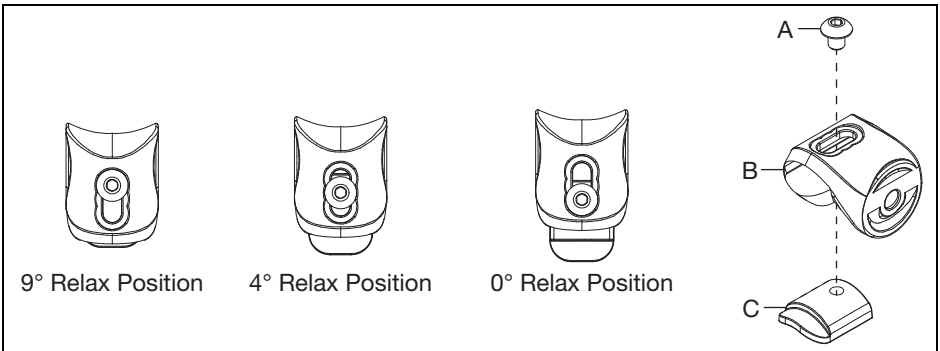

Backrest Assembly

3. Secure the new backrest plate (E) to the backrest post with the barrel nut (A) and 3/8" external retaining ring (J) using a pliers.
4. Secure the top of the backrest plate (E) to the backrest post with the shoulder bolt (C), fender washer (K) and nut (L) using a 3mm Allen wrench and an 8mm wrench.
5. Install the adjustment screw plug cap (B) through the backrest plate. Install the bolt (F) in through adjustment screw plug cap (B) and secure by installing the plug cap adjustment screw (H) over the top and the 5/8" retaining ring (I) over the top of both plug cap pieces. See the zoomed in image below for details of this procedure.
6. Install the bolt (D) through the backrest plate into the strike (G).
7. Repeat steps on opposite side of the backpost.

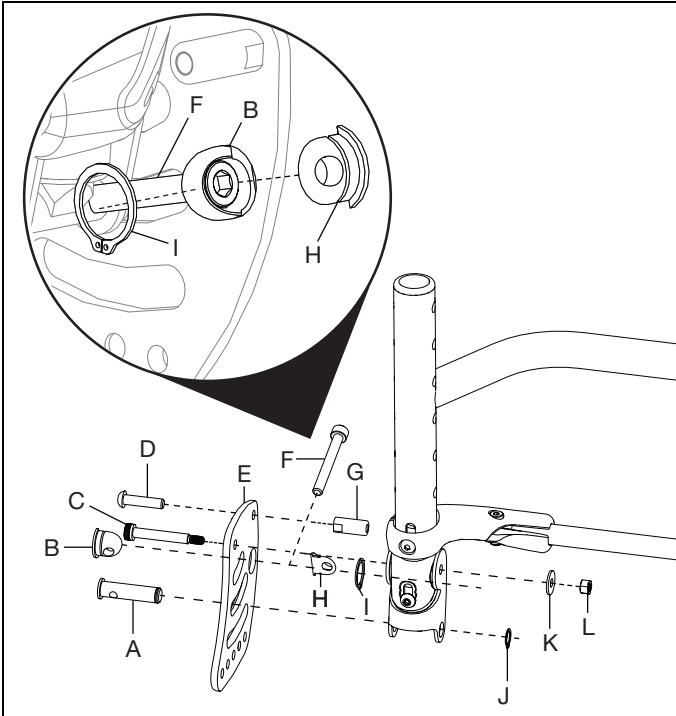

Backrest Assembly

8. Install the backrest assembly onto the chair with the hardware shown below. A 10mm wrench and a 4mm Allen wrench are needed. See the table for specific center of gravity configurations.

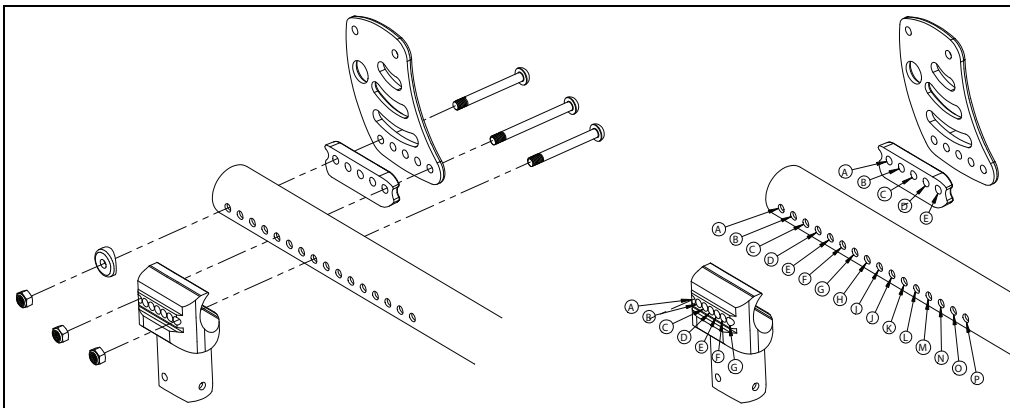

	Stackup	Nut/Tower/Tube	Nut/Tower/Tube/Large Saddle/Bracket	Nut/Tube/Large Saddle/Bracket	Nut/Small Saddle/Tube/Large Saddle/Bracket
		Total Length	55.5mm	65mm	50.5mm
	Bolt Needed	003232 (55mm)	107138 (65mm)	101781 (50mm)	003232 (55mm)
STANDARD TOWER	MX-TOWER				
CENTER OF GRAVITY	-1.5		A/A	E/C/A	G/E
	-1.25		B/A	F/C/B	F/E
	-1			C/B/A, G/D/C	F/E
	-0.75			B/A/A, F/C/C	F/E
	-0.5			A/A/A, G/D/D	E/E
	-0.25	-1.5		B/B/B, F/D/D	
	0	-1.25		A/B/B, G/E/E	A/A
	0.25	-1		B/C/C, F/E/E	A/A
	0.5	-0.75		A/C/C, E/E/E	A/A
	0.75	-0.5		B/D/D, D/E/E	A/A
	1	-0.25	G/G	C/E/E	A/A
	1.25	0	F/G	B/E/E	A/A
	1.5	0.25	G/H	A/E/E	A/A
	1.75	0.5	B/F, F/H		A/A, D/D
	2	0.75	A/F, G/I		A/A
	2.25	1	B/G, F/I		A/A, D/D
	2.5	1.25	A/G, G/J		A/A, E/E
	2.75	1.5	B/H, F/J		A/A, E/E
	3	1.75	A/H, G/K		A/A, E/E
	3.25	2	B/I, F/K		A/A, E/E
	3.5	2.25	A/I, G/L		A/A, E/E
	3.75	2.5	B/J, F/L		A/A, E/E
	4	2.75	A/J, G/M		A/A, E/E
	4.25	3	B/K, F/M		A/A, E/E
	3.25	A/K, G/N		A/A, E/E	
	3.5	B/L, F/N		A/A, E/E	
	3.75	A/L, G/O		A/A, E/E	
	4	B/M, F/O		A/A, E/E	
	4.25	A/M, G/P		A/A, E/E	

HOLE ALIGNMENT

Backrest Assembly

Adjusting Backrest Angle

1. The backrest angle can be adjusted by using a 5mm Hex drive, as shown below. Turning the hex drive clockwise decreases the backrest angle and turning it counterclockwise increases the angle. Each angle indicator mark on the back plate is 3° and 3° of angle change takes roughly 2.5 turns.

NOTE: Ensure both sides of the backrest are set in the same position. Use the angle indicator marks as a guide.

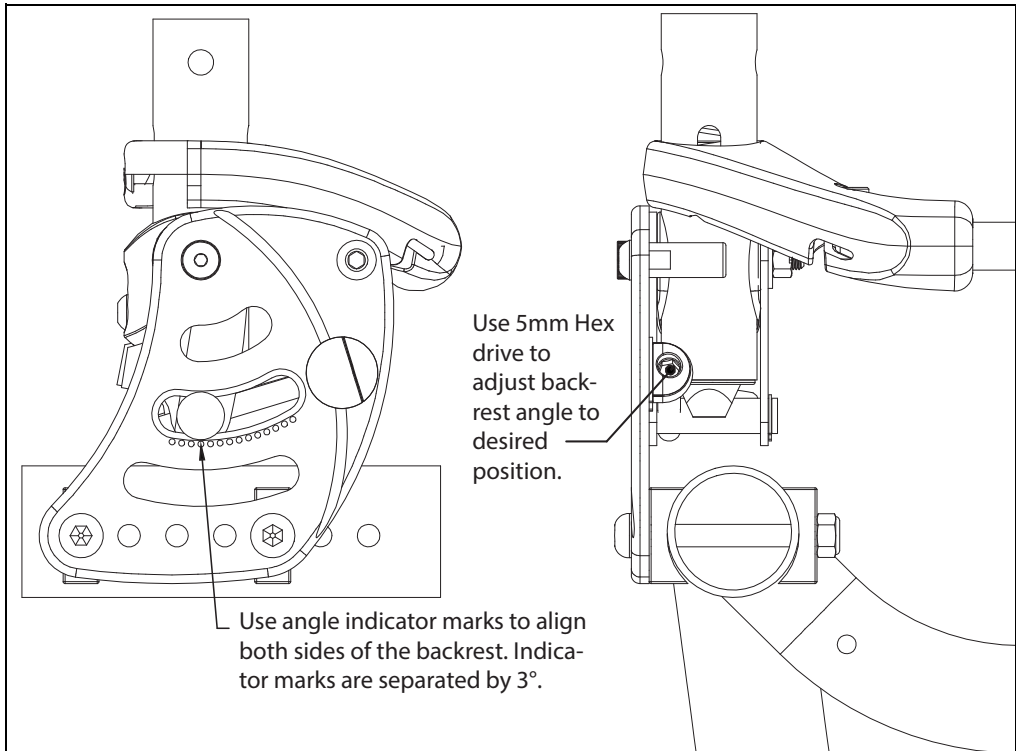

Height Adjustable Back Post

1. Install the height adjustable back post (F), plugs (G), sleeve (E), screws (C), threaded barrels (D) and the upper back tube assembly (A) using two 3mm Allen wrenches.

NOTE: The straight upper back, standard push handle and fold down push handle upper backs are shown in the image below.

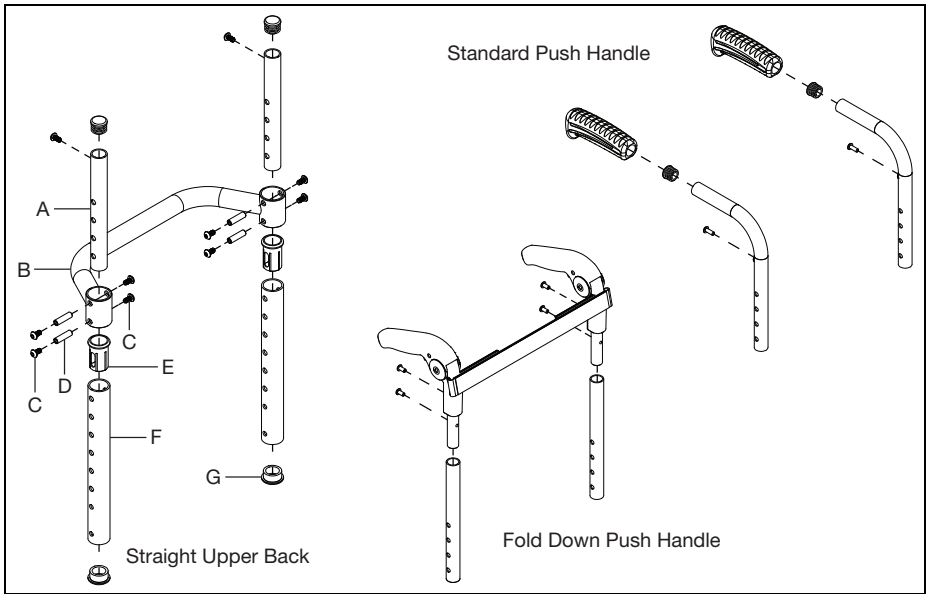

Fixed Height Back Post

1. For the fixed height back post, install the rigidizer bar (D), screws (A & C), threaded barrels (B) and plugs (E) using two 3mm Allen wrenches.

NOTE: The fixed height back post, standard push handle and fold down push handle upper backs are shown in the image below. The standard push handle and fold down push handle upper backs also require sleeves, upper post assemblies and the handle hardware. See image below for details.

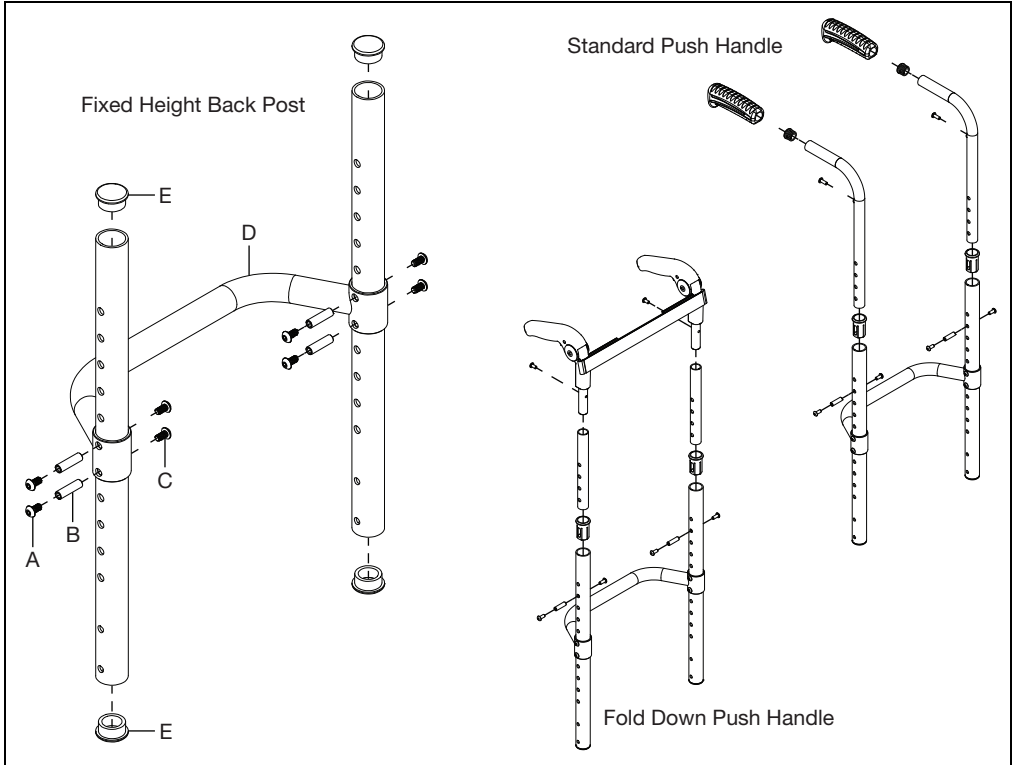

Rigid Stroller Handle

1. Install the stroller handle clamp (E & G) onto the rigidizer bar and secure with two screws (I) and a set screw (H) using a 5mm Allen wrench. The clamps can be installed in the straight mount configuration or the angled mount configuration. See image below.
2. Install the backpost (C), with the handles (A) and plugs (B) installed, into the clamp and secure by installing the clamp handle (D) and nut (F) using a 10mm wrench.

NOTE: The detent button on the bottom of the back post will click into place when properly installed.

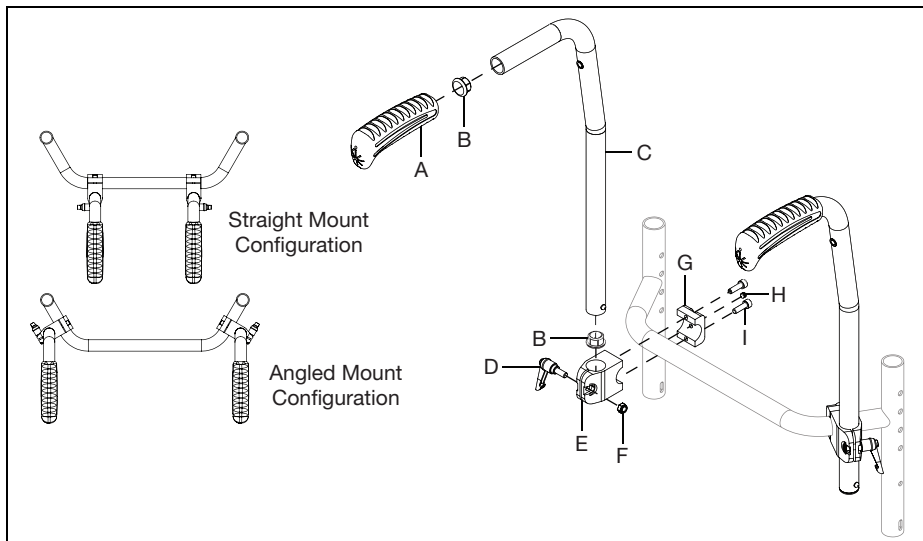

Ergo Stroller Handle

1. Install the ergo stroller handle clamp (F & H) onto the middle of the rigidizer bar and secure with two screws (I) and a set screw (J) using a 5mm Allen wrench.
2. Install the backpost (C), with the handle (A) and plug (B) installed, into the clamp and secure by installing the clamp handle (E) and nut (G) using a 10mm wrench.

NOTE: The detent button (D) on the bottom of the back post will click into place when properly installed.

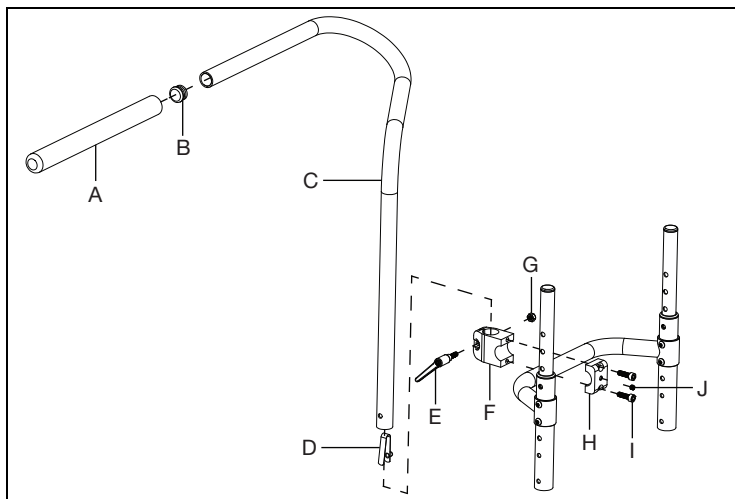

Bolt-On Push Handle

1. Install the clamps (B & C) and bolt-on push handle tube (E) onto the rigidizer bar and secure with two screws (A) and two nuts (D) using a 5mm Allen wrench.

NOTE: The clamps can be installed onto the rigidizer bar in the straight or angled orientation. See image below for details.

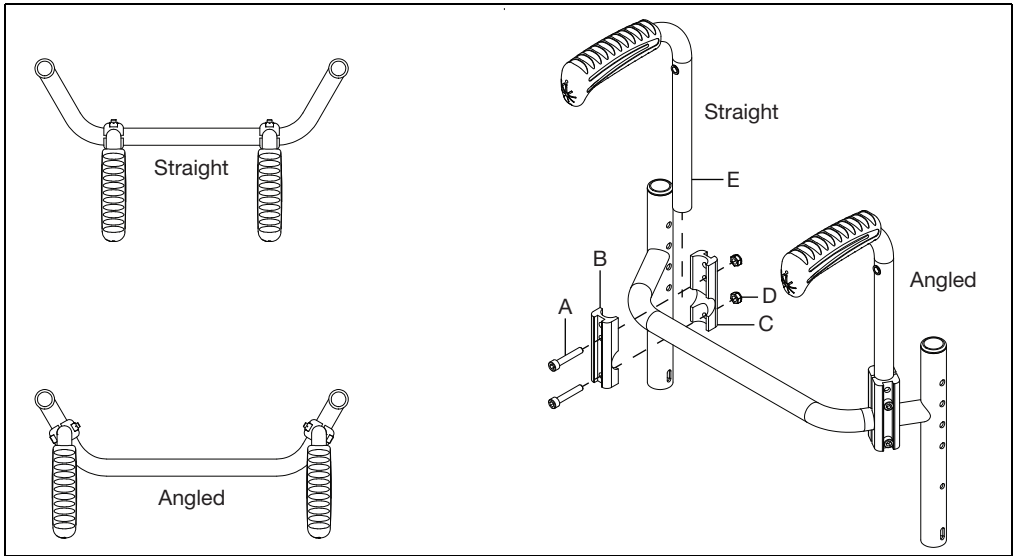

2. Repeat installation step with the second bolt-on push handle.

Height Adjustable T-Arm

1. Install the T-Arm receiver (B) and the T-Arm bracket (C) onto frame with two bolts (D) and two nuts (A) using a 5mm Allen wrench and a 10mm wrench.

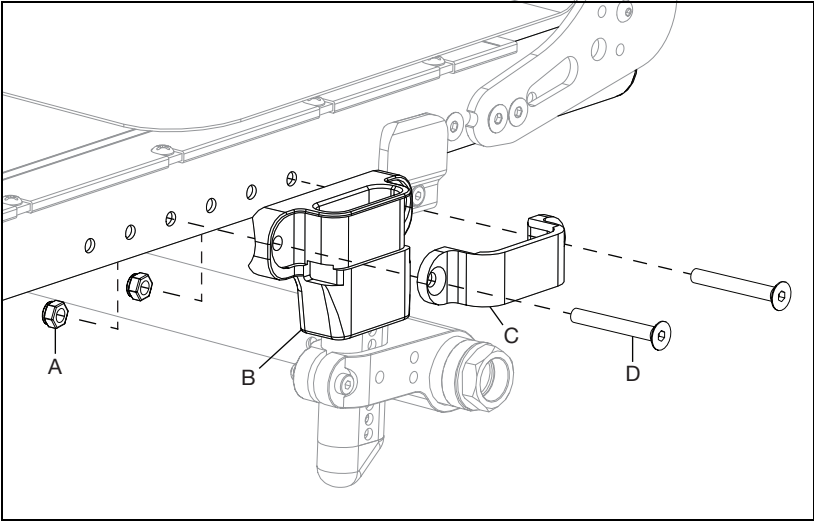

2. Install the T-Arm assembly into the receiver. Ensure the latch (B) "clicks" into place. Adjust the height by loosening the height lever (A) and sliding the T-Arm post up or down. Repeat steps on opposite side.

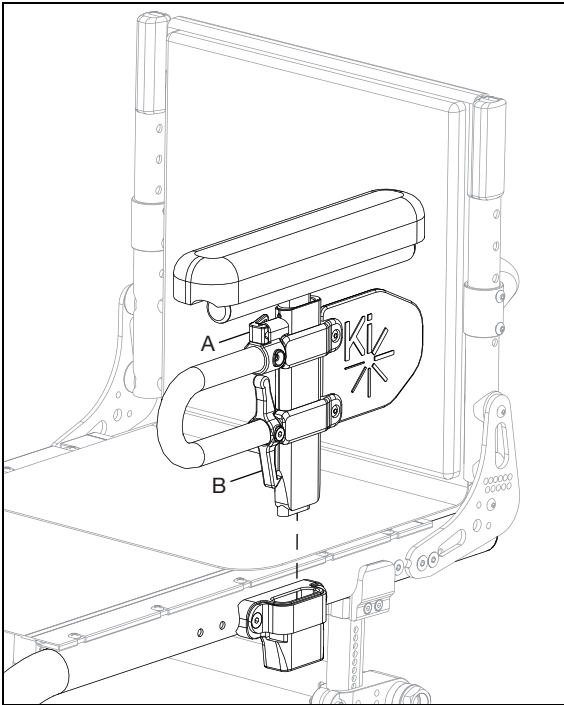

Angle Adj. Locking Flip Up Extendable Armrest - Available on Little Wave

1. Set the angle of the armrest. There are five holes that can be used to set the angle. Tighten the bolt once angle is set.

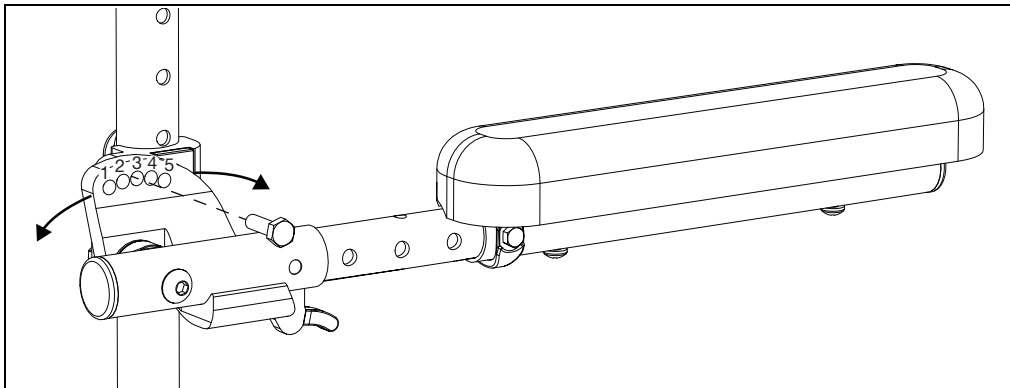

2. Set the length of the armrest. To adjust the length, remove the bolts and spacer on the tube and the screw closest to the back of the chair. Slide the armrest to desired length available by the predrilled holes and reinstall the screw and bolts.

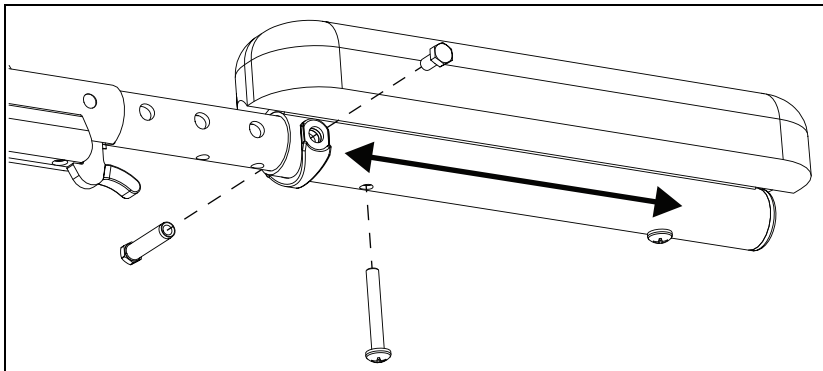

3. Set the height of the armrest. There are four holes on the armrest that allow for two different height settings for each set of holes on the back tube. Use the holes that provide the correct height setting for the user. The two bolts pass through the spacer, sleeves, back posts and into the armrest.

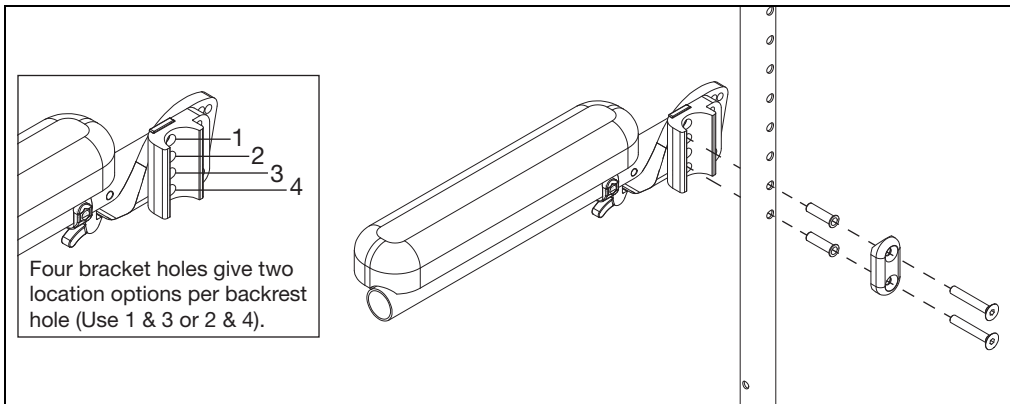

Swing Away Armrest

1. Install the swing away arm mount (C) onto the end of the frame tube with two bolts (D), bushing (B) and two nuts (A) using a 4mm Allen wrench and a 10mm wrench. Repeat on opposite side.

NOTE: Depending on the configuration, the backrest hardware may need to be removed to install the arm mount. Reinstall with the same hardware once the arm mount is in place.

NOTE: If you are installing the Rogue ALX mount shown below, the next step of installing the receiver can be skipped because the receiver and mount are one piece. The Rogue ALX version is not angle adjustable.

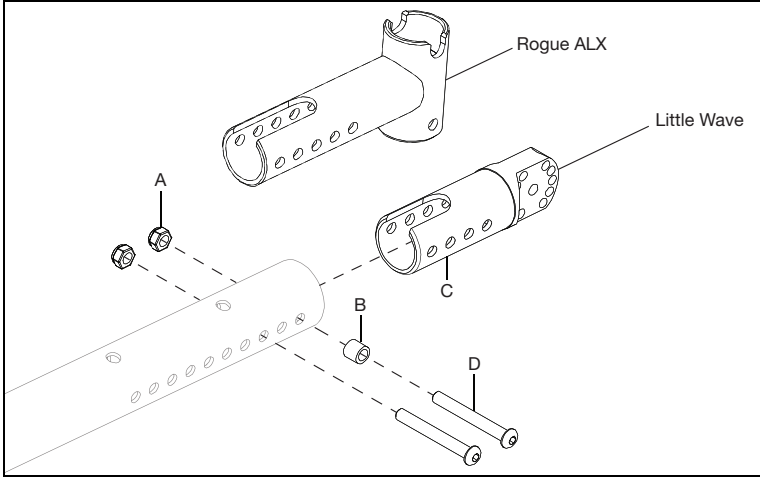

2. Install the swing away receiver (F) onto the swing away arm mount with three bolts (G & H) and three nuts (D & E) using a 3mm Allen wrench, a 4mm Allen wrench, an 8mm wrench and a 10mm wrench. Repeat on opposite side.
3. Finish by installing the two bolts (A) and the threaded barrel (C) using two 5mm Allen wrenches. The hole that the two bolts and the threaded barrel are installed in determine the armrest height. Finish by dropping the armrest into the receiver. Repeat on opposite side.

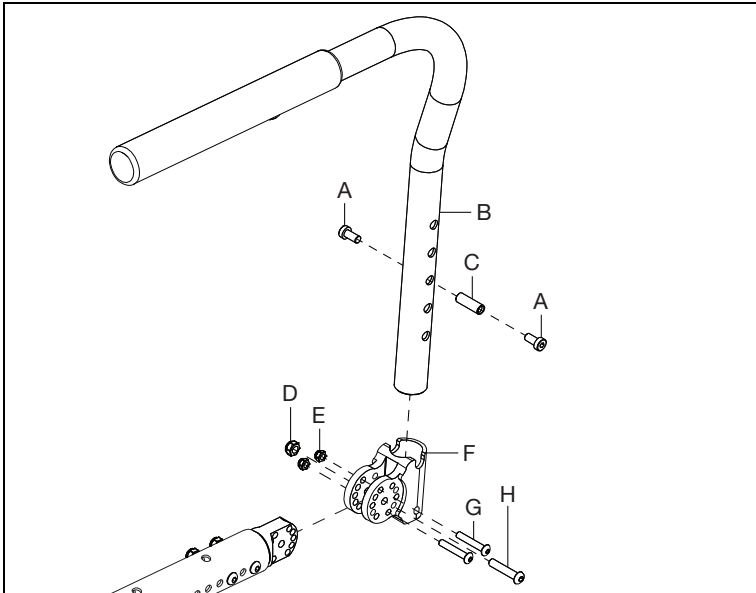

Cane and Crutch Holder

1. Install crutch holder cup (I) onto the crutch holder tube (F) with two screws (J), two washers (H) and two nuts (G) using a 3mm Allen wrench and an 8mm wrench.
2. Install the crutch holder tube assembly onto the camber tube with the clamps (D & E) and two bolts (C) using a 5mm Allen wrench.
3. Install the crutch holder velcro strap (A) onto the back post (ensure the crutch holder cup and velcro strap are on the same side of chair) with a screw (B) using a 3mm Allen wrench.

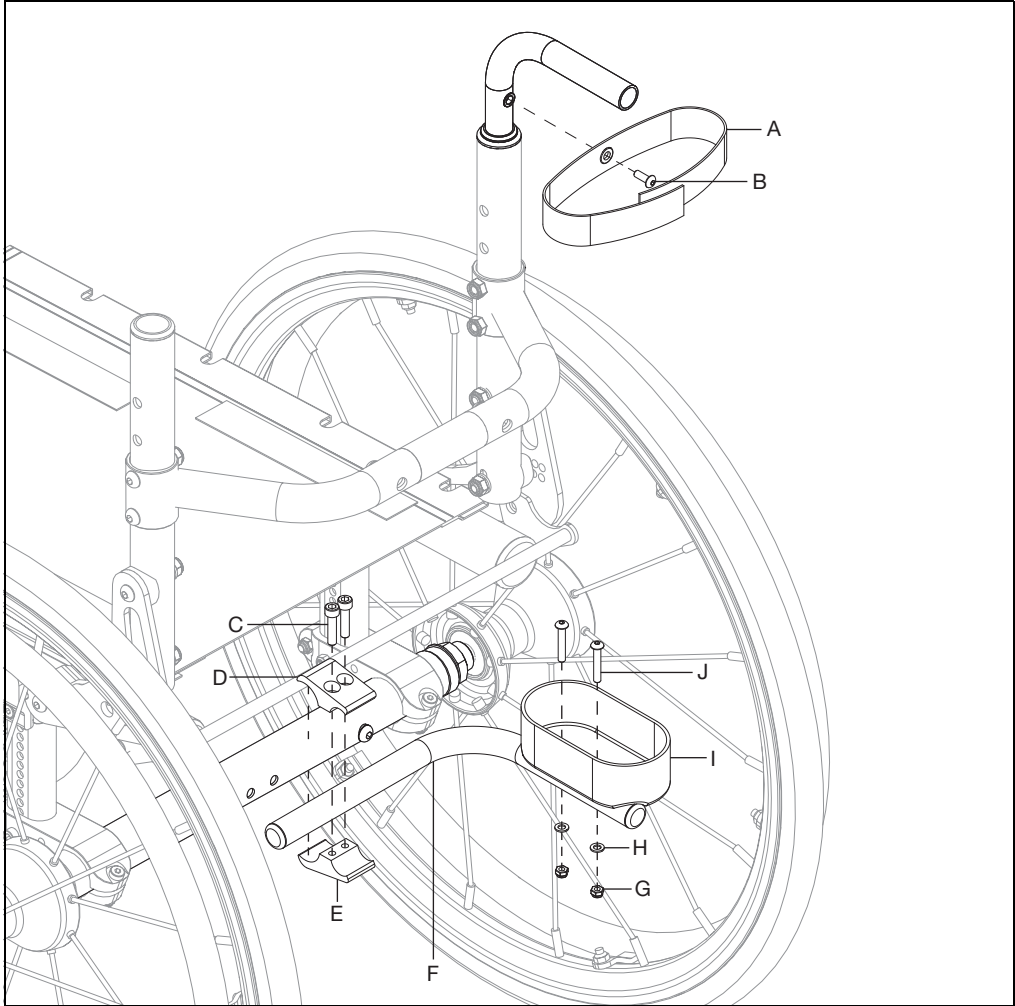

Luggage Carrier

NOTE: There are different sizes of clamps to fit all types of chairs and configurations. The carrier is mounted to the frame or footrest tube on rigid chairs and mounted on the footrest hangers or extension tubes on catalysts and tilt chairs. If hangers have been omitted the carrier is mounted to the vertical front frame tube. The image below shows a luggage carrier being installed on a chair with a footrest extension. The installation is the same whether it is being installed on the frame or footrest tubes.

1. Install luggage carrier fork (F) and clamp (B) by installing two screws (E) and barrel nut (D) through the clamp and fork using two 4mm Allen wrenches.
2. Secure the clamp in the desired location by installing and tightening the screw (A) and nut (C) on the backside of the clamp using a 5mm Allen wrench.

NOTE: The nut for the backside screw goes into a recess in the clamp. Ensure that nut stays in place.

3. Repeat on opposite side.

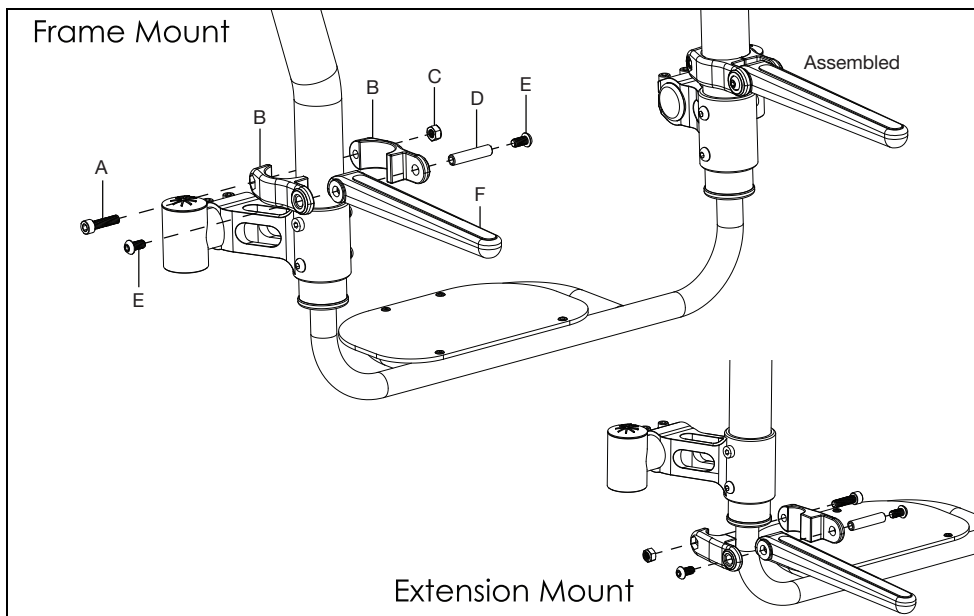

Using the Luggage Carrier

1. Operating position for the luggage carrier is when the forks are folded down (See image below). The max weight capacity is 55lbs.
2. When not in use, fold the luggage carrier up.

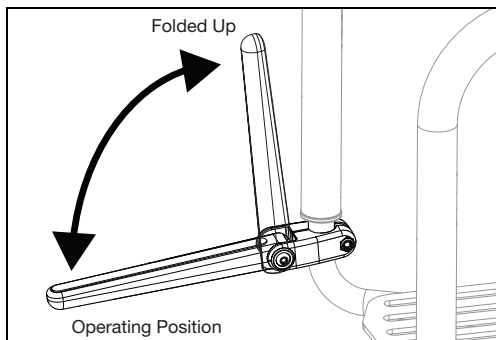

Handrim Configurations

NOTE: Not all wheels listed below are available for specific models. See an order form or the online parts manual for more information on your specific chair model.

Handrim Hardware Chart																	
Wheel		Handrim Connection				Handrim											
Wheel	Wheel Part No.	Connection Points	Rivet/Tab	Spacer*	Screw*	Aluminum Anodized	Superlight	Plastic Coated	Projection	Ergonomic Standard	Ergonomic LT	Natural Fit Standard	Natural Fit LT	Flex Rim			
22" Spoke	18730	5 or 6	18732 (Used with 5 Rivet) 100698 (Used with 6 Rivet)	100653 (Not used w/ Superlight Handrim)	Aluminum, Plastic Clid, Projection, Ergonomic: 100654 Natural Fit: 100835 Superlight: Screw: 100669 Nut: 100657	10898 (5 Rivet)		10964 (5 Rivet)	12824 (6 Rivet)	13082 (6 Rivet)	13085 (6 Rivet)	200538 (6 Rivet)	200201 (6 Rivet)				
24" Spoke	18728	5 or 6	Not used w/ Superlight Handrims			100975 (5 Rivet)	10161 (6 Tab)	100976 (5 Rivet)	12825 (6 Rivet)	13083 (6 Rivet)	13086 (6 Rivet)	100793 (6 Rivet)	200202 (6 Rivet)				
18" MAXX Spoke	109285	3				100206											
20" MAXX Spoke	108244	6	100698 (Not used w/ Superlight Handrim)	100653 (Not used w/ Superlight Handrim)	Aluminum, Plastic Clid, Projection, Ergonomic: 100654 Natural Fit: 100835 Superlight: Screw: 100669 Nut: 100657	200536		12828									
22" MAXX Spoke	10505					100560		12820	12824	13082	13085	200538	200201				
24" MAXX Spoke	10506					200349	10161	12821	12825	13083	13086	100793	200202				
25" MAXX Spoke	107436					200350		12822	200548	13084	13087	200539	200540				
26" MAXX Spoke	107437					200351		12823	200549			100907	10454				
20" MAXX Mag	11853					6		Aluminum, Plastic Coated, Projection: 100629 Natural Fit & Ergonomic: 101756	Aluminum, Plastic Coated, Projection, Ergonomic: 103545 Natural Fit: 10893	200536		12828					
22" MAXX Mag	11854	100560		12820	12824					13082	13085	200538	200201				
24" MAXX Mag	11855	105137		12821	12825					13083	13086	100793	200202				
24" Superlight	10169	6			100536	100754	10161	100836		13080	13081	100830	100828				
25" Superlight	10160						10160	10161			10464	10460					
20" Spineray Spox	See Spineray Spox Page									103125		103179					
22" Spineray Spox										100827		100808			100889	100888	
24" Spineray Spox										100766	10161	10066			100830	100828	
25" Spineray Spox										100767	10160	100765			10464	10460	
26" Spineray Spox						10477		10148			200200	100950					
22" Spineray LX		See Spineray LX Page					100827		100808				100889	100888			
24" Spineray LX						100766	10161	10066		13080	13081	100830	100828				
25" Spineray LX						100767	10160	100765				10464	10460				
26" Spineray LX						10477		10148				200200	100950				

* Spacer and screw part numbers listed in the chart are for standard handrim mounting. If using close mount handrim mounting on aluminum anodized, plastic coated or projection handrims, use part number 100792 for the spacer, part number 10266 for the screw on Ki Spoke and MAXX Spoke wheels, part number 100666 for the screw on 5-Spoke X Core wheels, or part number 100654 for the screw on MAXX Mag wheels.

Handrim Hardware Chart (Discontinued Wheels)														
Wheel		Handrim Connection				Handrim								
Wheel	Wheel Part No.	Connection Points	Rivet/Tab	Spacer*	Screw*	Aluminum Anodized	Superlight	Plastic Coated	Projection	Natural Fit Standard	Natural Fit LT	Flex Rim		
18" Ki Spoke	200529	3				100206		10106						
20" Ki Spoke	200530	6	100698	100653	Aluminum, Plastic Clid, Projection: 100654 Natural Fit: 100835	200536		200542						
22" Ki Spoke	200531					100560	100576	100569	200538	200201				
24" Ki Spoke	200532					200349	100577	200547	100793	200202				
25" Ki Spoke	200533					200350	10160	200548	200539	200540				
26" Ki Spoke	200534					200351	100578	200549	100907	10454				
20" 5-Spoke X Core	10961					5		Aluminum, Projection, Natural Fit: 100629	100724	10897		10963		
22" 5-Spoke X Core	10962	10898		10964										
24" 5-Spoke X Core	100980	100975		100976	200546									
24" 5-Spoke X Core	100980									100768	100769			

* Spacer and screw part numbers listed in the chart are for standard handrim mounting. If using close mount handrim mounting on aluminum anodized, plastic coated or projection handrims, use part number 100792 for the spacer, part number 10266 for the screw on Ki Spoke and MAXX Spoke wheels, part number 100666 for the screw on 5-Spoke X Core wheels, or part number 100654 for the screw on MAXX Mag wheels.

Handrim Construction

The sequencing of hardware for the three styles of handrims is shown below. The specific hardware used is determined in the chart on the previous page, based on the tire and handrim being used.

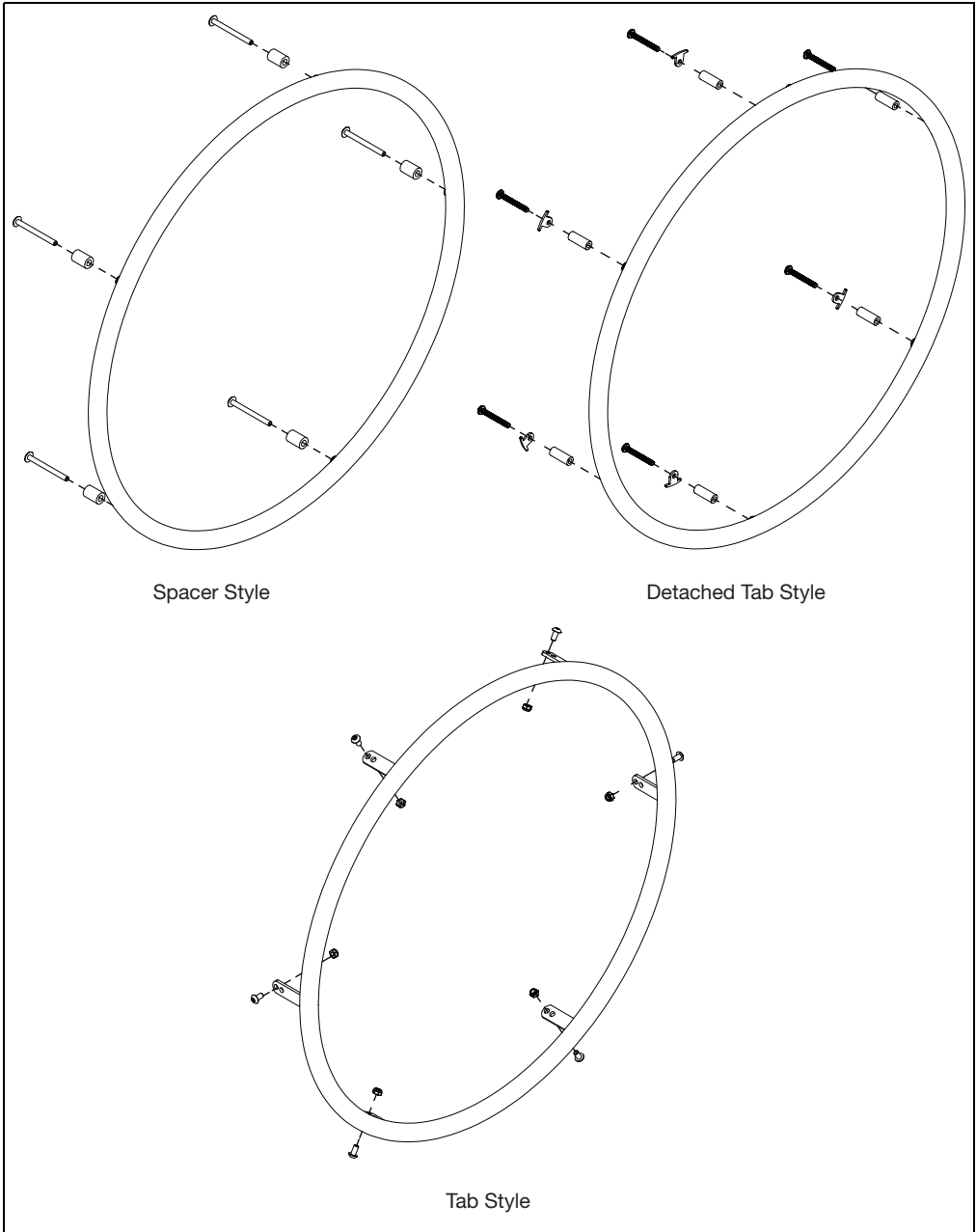

Seat Pan

NOTE: Remove any current seating or cushions before installing the seat pan.

3. Install the seat pan (B) onto the chair frame and secure with screws (A) using a Phillips screwdriver.
4. If not already done, install the AB Tape onto the seat as shown in the image below. The AB Tape should cover as much area as possible without hanging over the edge or covering one of the screw holes.

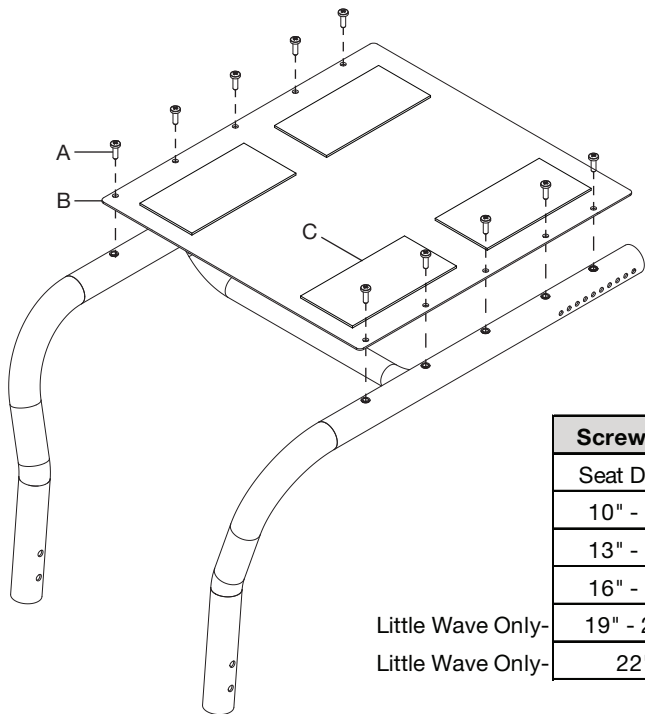

Screw Qty Per Chair	
Seat Depth	Screw Qty
10" - 12"	6
13" - 15"	8
16" - 18"	10
19" - 21"	12
Little Wave Only- 22"	14

Part Number	AB Tape Size	Seat Pan Depth
004458	3" X 4"	10" - 11"
004458 & 004459	3" X 4" & 3" X 5"	12"
004459	3" X 5"	13"
004460	3" X 6"	14" - 22" (19" - 22" Little Wave Only)

Seat Upholstery

1. Install the seat rail (B) into the sleeve on the edge of the seat upholstery (C). Repeat on opposite side. The seat rail is shown outside of the sleeve to show the hole alignment in the image below.
2. Secure the seat rail and seat upholstery onto the chair frame with screws (A) using a Phillips screwdriver.

Seat sling used on 10" - 13" wide

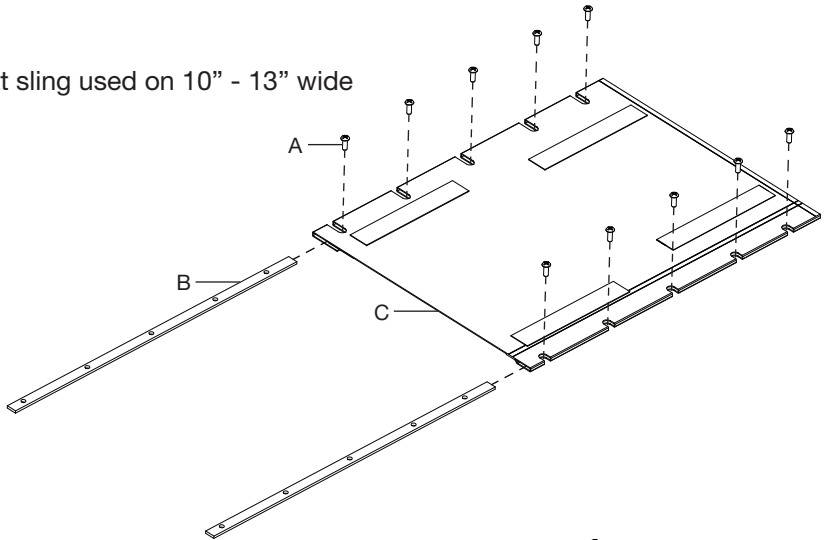

Seat sling used on 14" - 22" wide

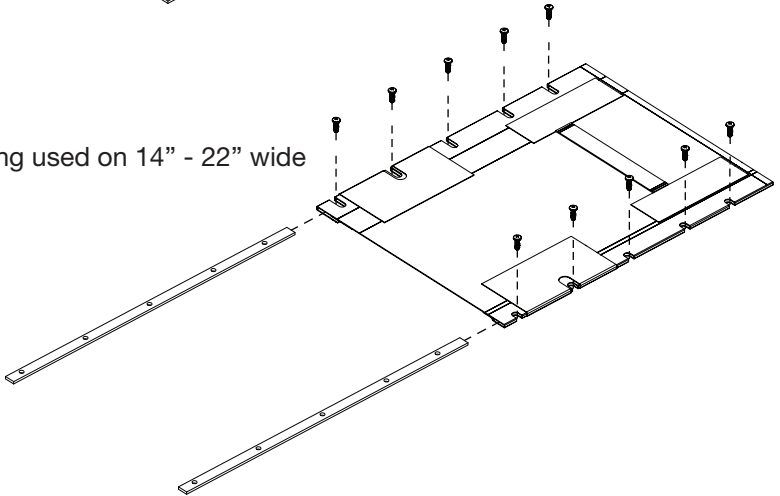

SCREW (ITEM 3) QTY PER CHAIR	
SEAT DEPTH	SCREW QTY
10" - 12"	6
13" - 15"	8
16" - 18"	10
19" - 21"	12
22"	14

Side Guards

Side Guard Receiver

1. There are three types of side guard receivers that may be used. The mounted side guard receiver (B) is installed onto the frame with screw (A), washer (C) and nut (D) using a 4mm Allen wrench and a 10mm wrench. The clamp side guard receivers (G & H) are installed onto the frame with two screws (E) and two washers (F) using a 5mm Allen wrench. The anti-rattle side guard receiver (I) is installed the same way as the clamp side guard receiver, it just has two additional rubber buttons (J) installed into the receiver. Repeat on opposite side.

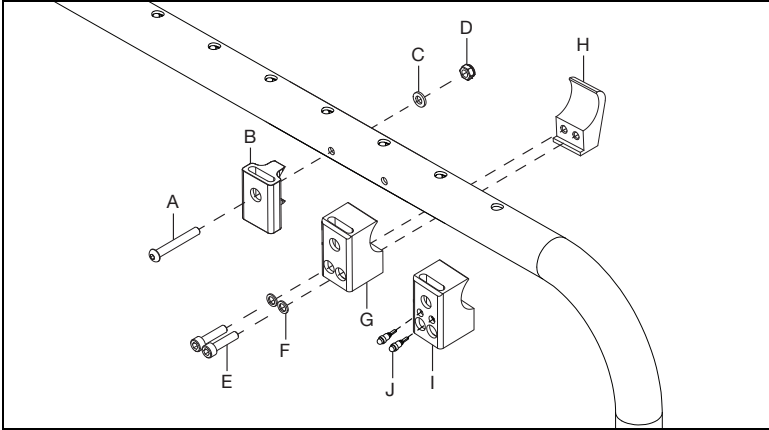

Removable Adult Side Guard

1. Install the adult side guard (D) onto the side guard post (C) with two screws (A) using a 4mm Allen wrench. On the opposite side, install the side guard post stop (B) with a screw (A) using a 4mm Allen wrench.

NOTE: Do not overtighten the post stop (B). Overtightening will flare the vertical sides outward which will prevent the post stop from functioning properly. Check that the post stop is snug, doesn't rattle and stays in place.

NOTE: There are two sets of holes that the side guard post (C) can be installed onto the side guard with. Choose the holes that place the side guard in the desired position. The height is also adjusted with the hole that the side guard post stop (B) is installed in.

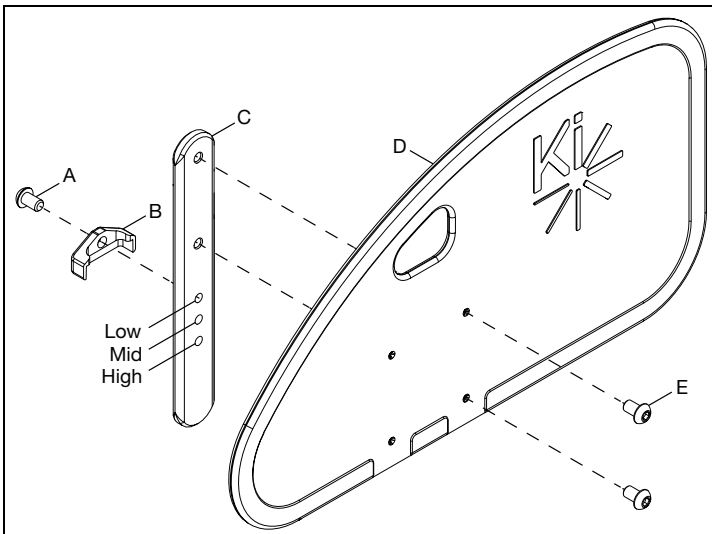

Side Guards

2. Install the side guard assembly into the receiver so the side guard post stop faces the outside of the chair.

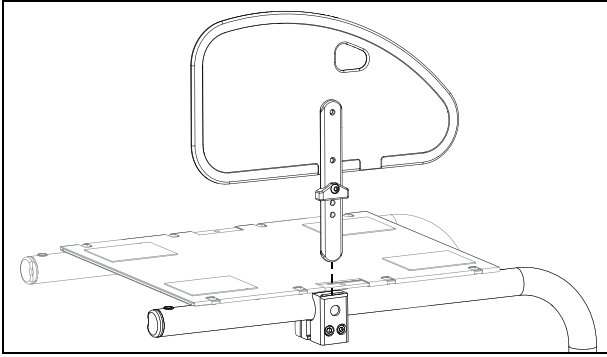

Removable Pediatric Side Guard

1. Install the pediatric side guard (D) onto the side guard post (C) with two screws (A) using a 4mm Allen wrench. On the opposite side, install the side guard post stop (B) with a screw (A) using a 4mm Allen wrench.

NOTE: Do not overtighten the post stop (B). Overtightening will flare the vertical sides outward which will prevent the post stop from functioning properly. Check that the post stop is snug, doesn't rattle and stays in place.

NOTE: The height of the pediatric side guard can be adjusted with the three holes on the side guard post (C).

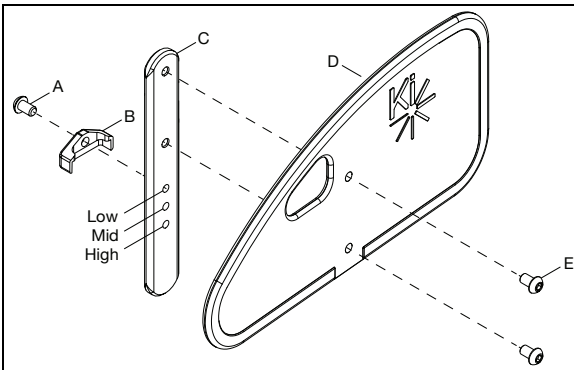

2. Install the side guard assembly into the receiver so the side guard post stop faces the outside of the chair.

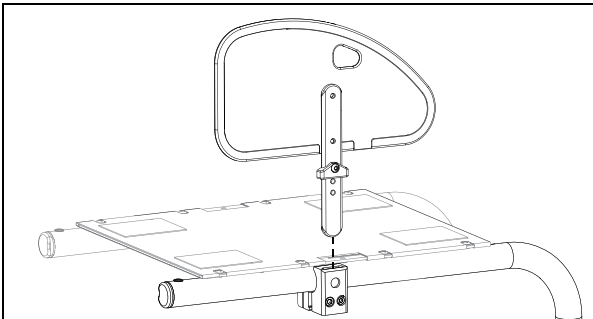

Side Guards

Adjustable Fender Side Guard

1. Install post (B), post mount plate (A) and bolts (D) onto the fender (C) using a 3mm Allen wrench.

NOTE: There are three mounting positions that can be used. Pick the holes that put the fender in the desired position for the occupant. This can be adjusted again later.

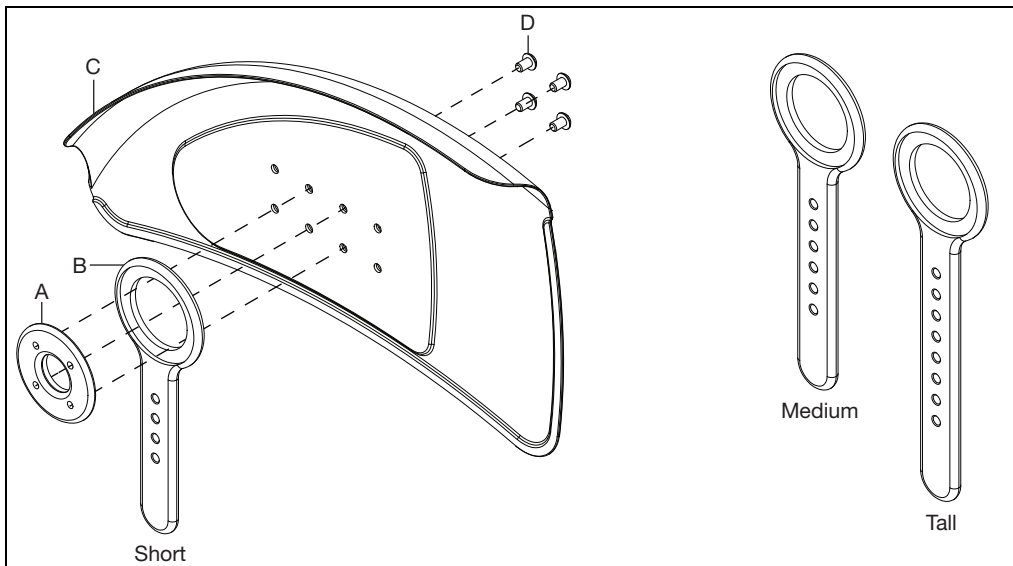

2. Set the height of the back post by installing the post stop (B) with a screw (A) using a 4mm Allen wrench. The height of the post can also be adjusted later if needed.

NOTE: It is possible to install the post stop (B) in a hole high enough that it will not mate to the receiver. Ensure fit after installment before using the side guard.

NOTE: Do not overtighten the post stop (B). Overtightening will flare the vertical sides outward which will prevent the post stop from functioning properly. Check that the post stop is snug, doesn't rattle and stays in place.

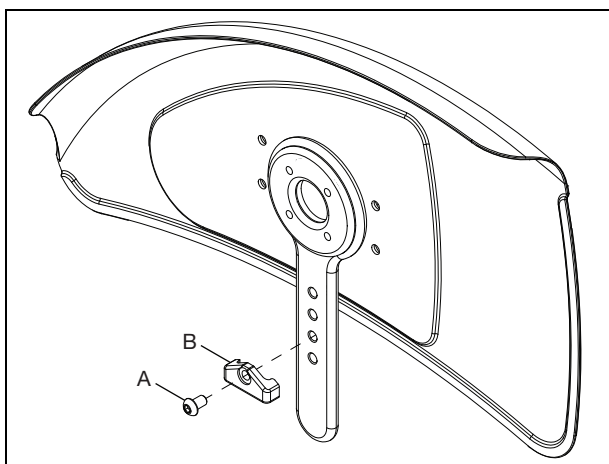

3. Install the fender assembly into the receiver by dropping the post into the receiver slot. Adjust the fender if needed.

4. Repeat steps on opposite side.

Side Guards

Angle Adjustments

The angle of the fender can also be changed to align the fender with the profile of the tire if needed.

1. Remove the four bolts from the post mount with a 3mm Allen wrench.
2. Rotate the fender, either way, to align the fender with the profile of the tire.
3. Rotate the post mount plate so the four holes align with the desired holes on the fender.
4. Reinstall the the four bolts securing the fender to the post and post mount plate using a 3mm Allen wrench.

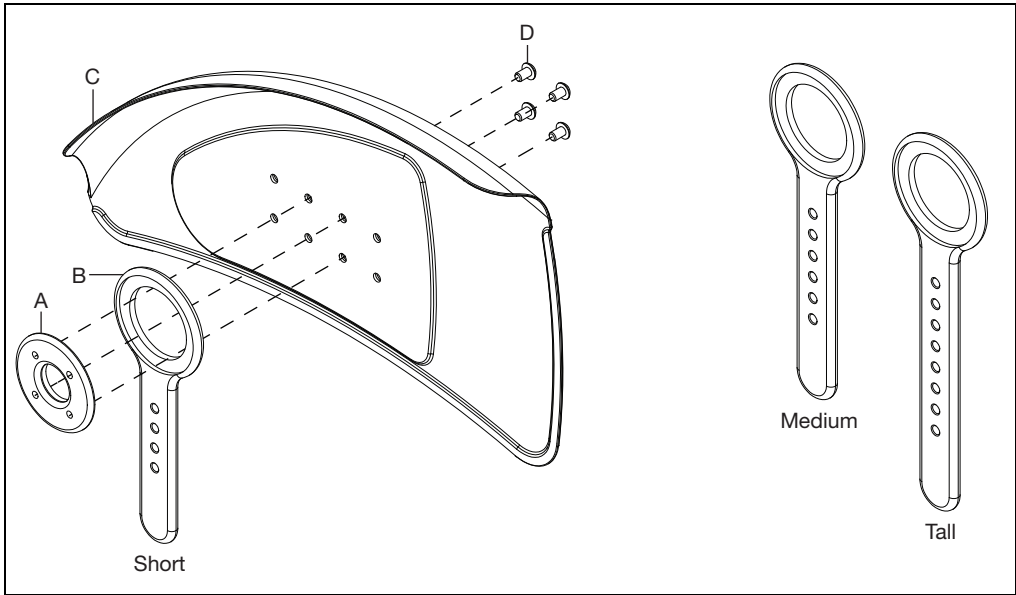

Transit

Rogue ALX Style Transit

1. Install the rear Rogue ALX Style Transit bracket (B) onto the chair frame with two bolts (D), two saddles (C) and two nuts (A) using a 4mm Allen wrench and a 10mm wrench.
2. Repeat steps on opposite side. Backrest is installed as shown in Backrest Assembly section.

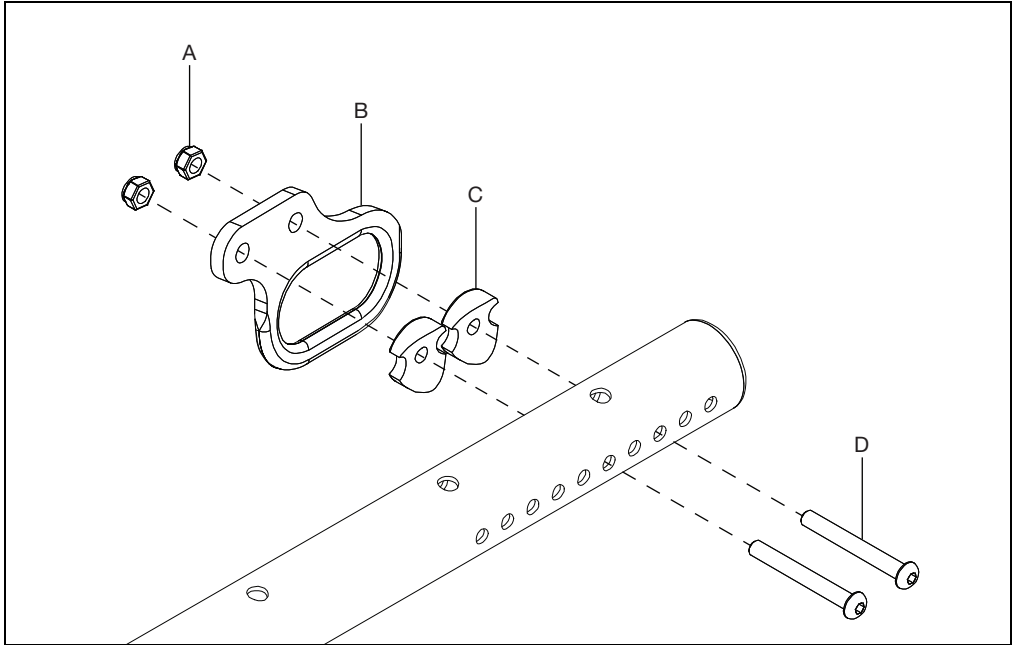

Caster Mount Transit Bracket

1. Install the caster mount transit bracket (A) over the caster mount bracket and secure with two bolts (B) using a 4mm Allen wrench. Repeat steps on opposite side.

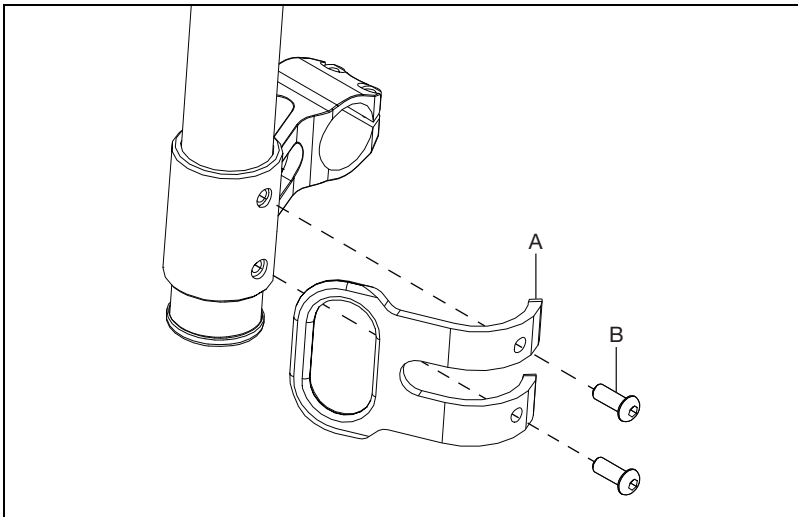

Transit

Locking Fold Down Backrest with Transit

NOTE: The new Locking Fold Down Backrest assembly, standard and transit, uses new backrest tubes. If the chair does not already have the new backrest design, new backrest tubes are needed as the old tubes are not compatible.

1. Remove any cushion or seating components that may be in the way during backrest removal. Also, remove any backrest tubes and/or handles that may be used after the backrest installation process.
2. Remove the current backrest assembly. See the Backrest Assembly section for removal instructions.

NOTE: Refer to parts manual for additional information on compatibility restrictions for the new backrest design.

3. Install the transit backrest plate (D) onto the frame with two bolts (E), back saddle (C), two saddles (B) and two nuts (A) using a 4mm Allen wrench and a 10mm wrench.
4. Repeat on opposite side.
5. The rest of the process for installing the backrest is the same as the Locking Fold Down Standard Backrest. See the Backrest Assembly section for remaining installation instructions.

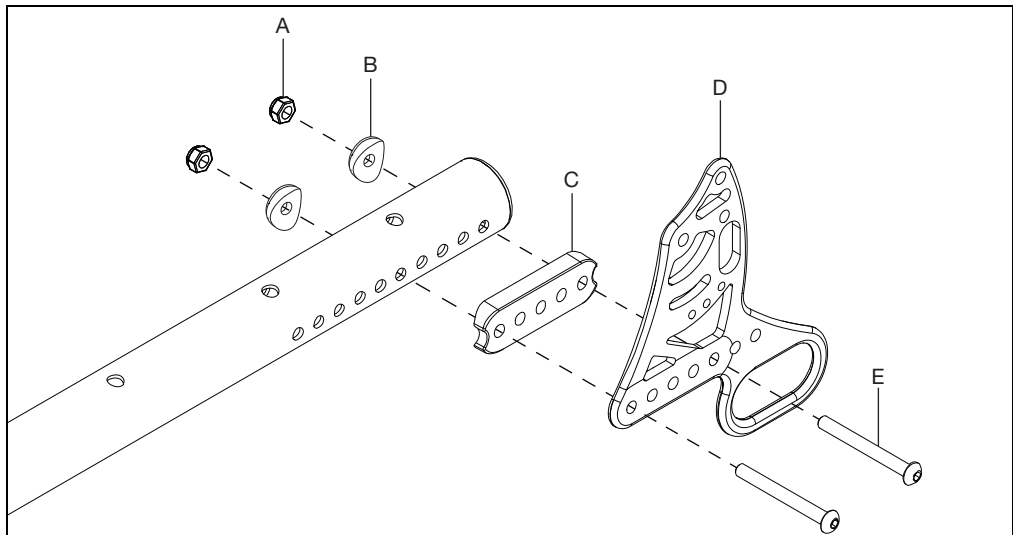

Bolt E

Length	When Used
50mm	When bolt goes through the frame, back bracket and back saddle.
55mm	When bolt goes through the tower and frame only. Also used when bolt goes through the frame, back bracket and back saddles.
65mm	When bolt goes through the tower, frame, back bracket and back saddle.

Angle Adjustable Footrest

1. Install the footrest extension tubes (A) into the footrest adjustable clamp (G).
2. Install the footplate (E) onto the clamp and secure with two screws (D) and two nuts (H) using a 5mm Allen wrench and a 10mm wrench. If a riser (F) is being used to elevate the footrest platform, install between the footrest platform and the footrest adjustable clamp.
3. Install the footrest protectors (C) by peeling the backing off of the tape (B) and sticking the tape inside the footrest protector. Peel the remaining backing off of the tape and snap footrest protectors onto the footrest as seen below.

Footrest Tube Width

Part No.	Width
000221	5.6"
000222	6.6"
000223	7.6"
000224	8.6"
000625	10.6"

Footplate Width

Part No.	Width
000225	6.0"
001322	7.0"
000226	8.0"
001323	9.0"
000227	10.0"
001319	12.0"

Apply tape to the inside of the footrest protectors.

Snap the footrest protectors onto the footrest.

Footrest Part Number Matrix

Seat Width	Front Seat Taper		
	0" Taper	1" Taper	2" Taper
10"	X00225		
11"	X01322		
12"	X00226	X00225	
13"	X01323	X01322	
14"	X00227	X00226	
15"	X00227	X01323	
16"	X01319	X00227	X00226
17"	X01319	X00227	X01323
18"	X01319	X01319	X00227
19"	X01319	X01319	X00227
20"	X01319	X01319	X01319
21"	X01319	X01319	X01319
22"	X01319	X01319	X01319

Angle Adjustable Flip Under Footrest

1. Install the footrest tubes (A & D) through the pivots (B) into the footrest flip stop clamp (C).

NOTE: The footrest tube and the footrest tube offset are shown below. The installation process is the same for both footrest tubes.

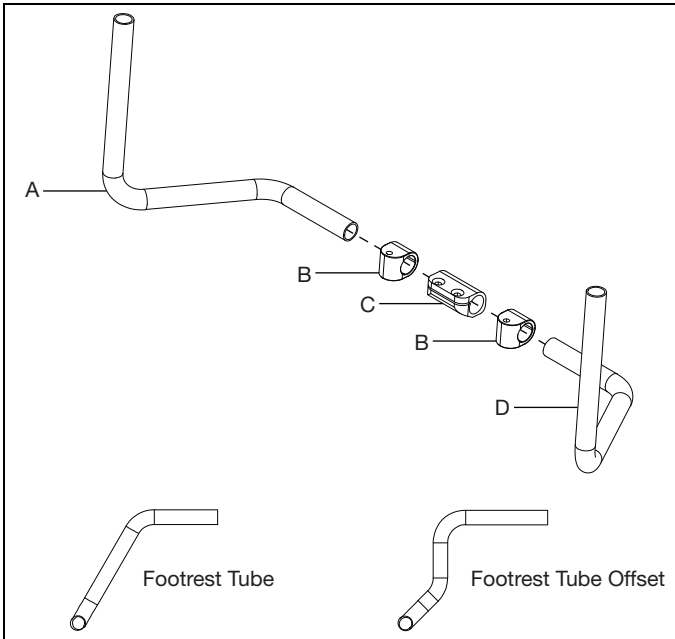

2. Install two screws (C) into the footrest flip stop clamp to secure the footrest tubes using a 5mm Allen wrench. Install the footrest platform (B) onto the footrest flip stop clamp with two screws (A) and two nuts (D) using a 5mm Allen wrench.

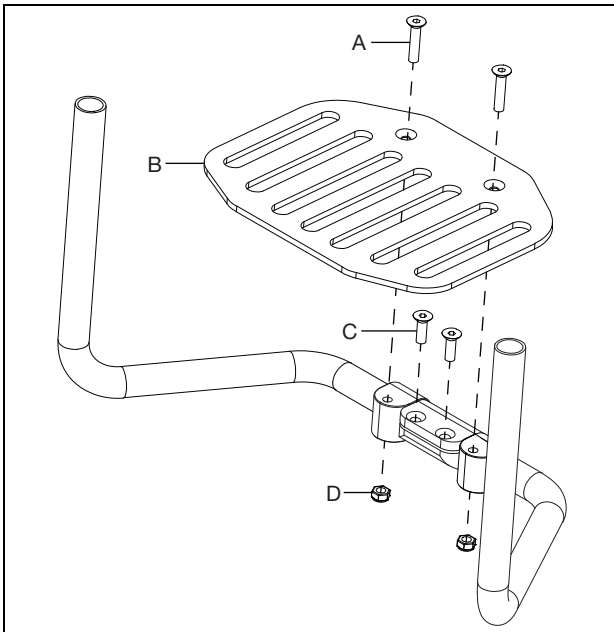

High Mount Angle Adjustable Footrest - Available on Rogue ALX

1. Install the footrest adjustable clamp (C) onto the extension tube (E). Install the footrest platform (B) onto the footrest adjustable clamp and secure with two screws (A) and two nuts (D) using a 5mm Allen wrench.

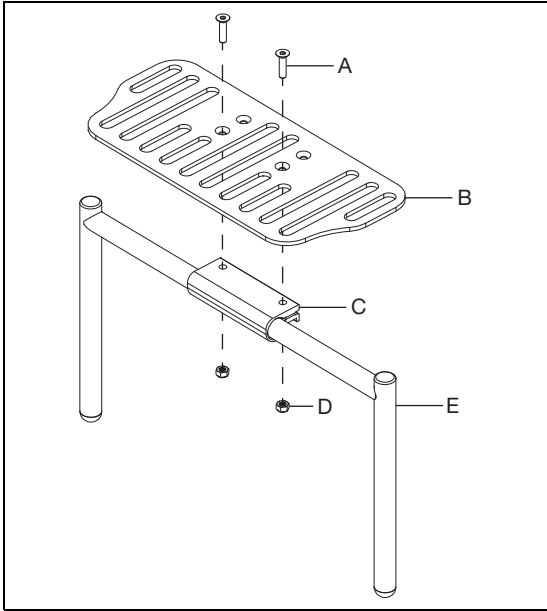

2. Install the two clamps (C & D), one end on the footplate riser tube and the other end around the frame tube, with two screws (A) and two lock washers (B) using a 5mm Allen wrench.

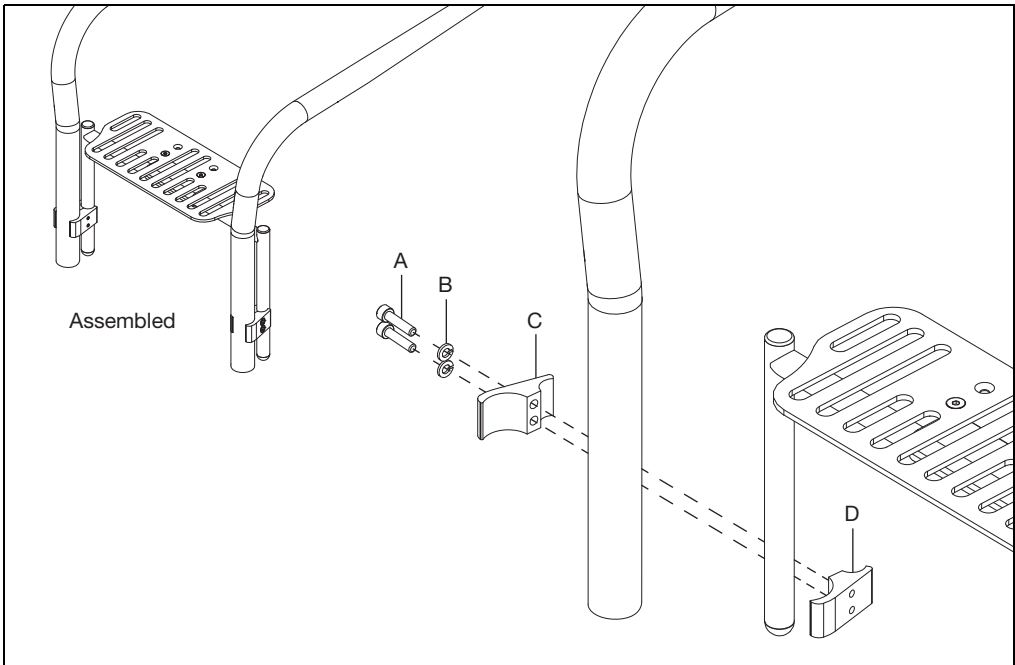

High Mount Angle Adj. Footrest (10"-14" Wide)

*** Available on Little Wave**

1. Install the footrest tubes (E) into the footrest adjustable clamp (H) and secure by installing the footrest platform (G) onto the clamp with two screws (F) and two nuts (I) using a 5mm Allen wrench. Install the footplate risers (D) onto the footrest tubes with screws (A) and saddles (C) using a 4mm Allen wrench. Install plugs (B) into the end of the footrest tubes.

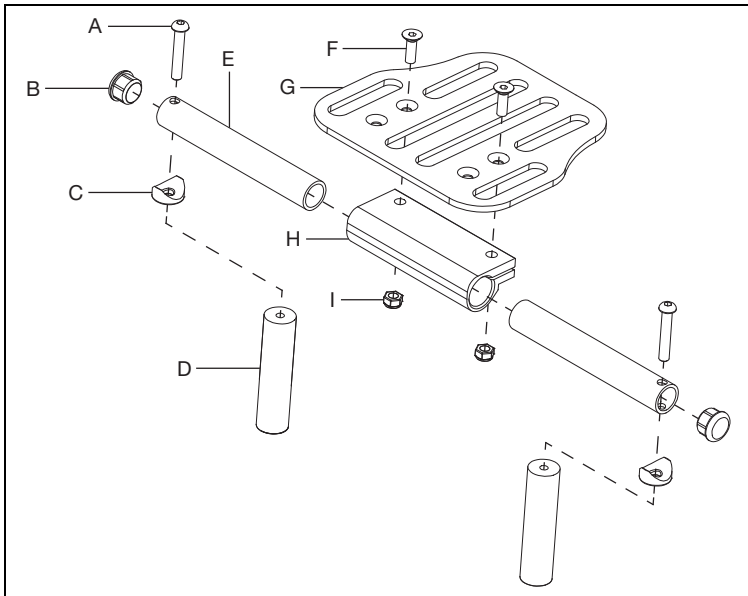

2. Install the two clamps (A & B), one end on the footplate riser tube and the other end around the frame tube, with two screws (D) and two lock washers (C) using a 5mm Allen wrench.

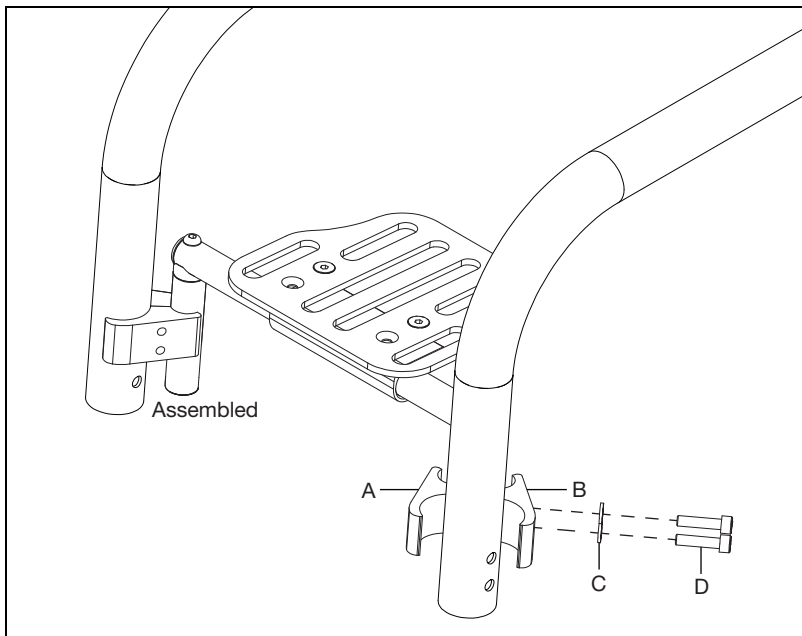

High Mount Angle Adjustable Footrest (15" - 19" Wide)

*** Available on Little Wave**

1. Install the footrest tubes (B) into the footrest adjustable clamp (E) and secure by installing the footrest platform (D) onto the clamp with two screws (C) and two nuts (F) using a 5mm Allen wrench. Install the plugs (A) into the ends of the footrest tubes.

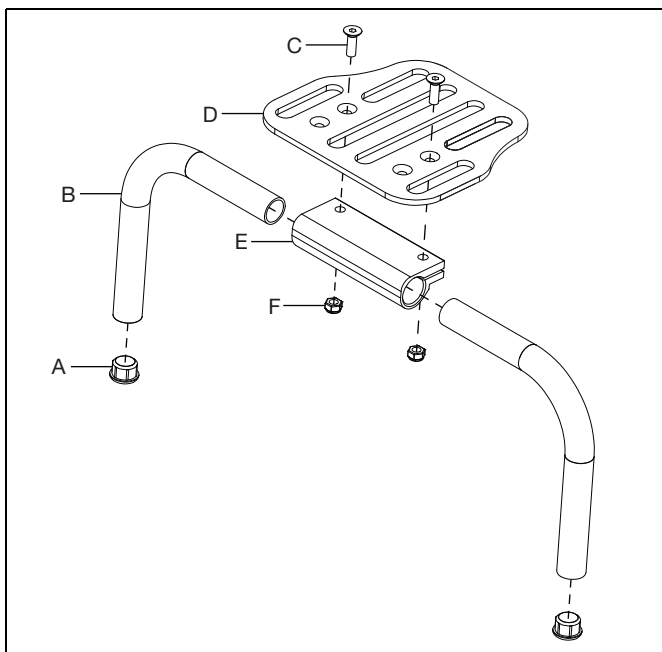

2. Install the two clamps (A & B), one end on the footplate tube and the other end around the frame tube, with two screws (D) and two lock washers (C) using a 5mm Allen wrench.

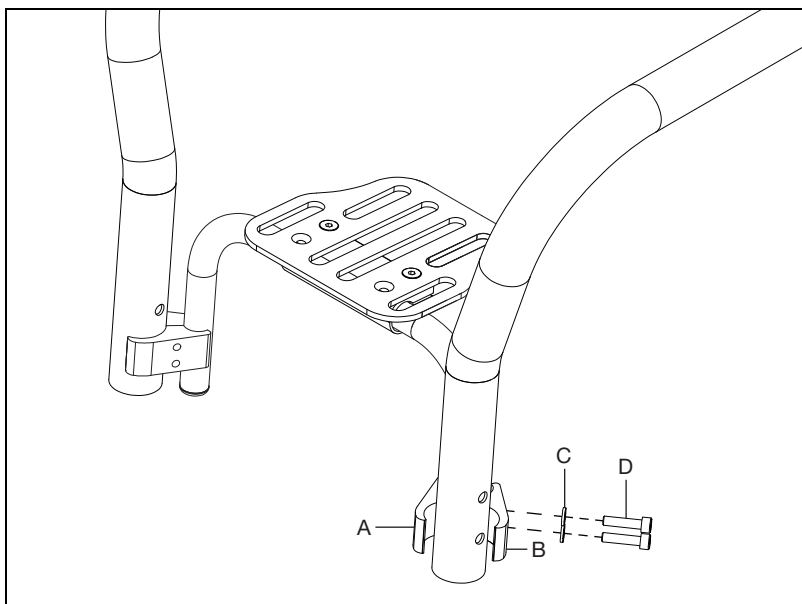

High Mount Angle Adjustable Flip Under Footrest

1. Install the pivots (B) and clamp (D) onto the footrest tube (A) and secure with two screws (C) using a 5mm Allen wrench.
2. Install the bracket (F) onto the end of the footrest tube and secure with screw (E) using a 4mm Allen wrench.
3. Install the footrest flip mount tube (H) onto the bracket with two screws (I) and two saddles (G) using a 4mm Allen wrench.

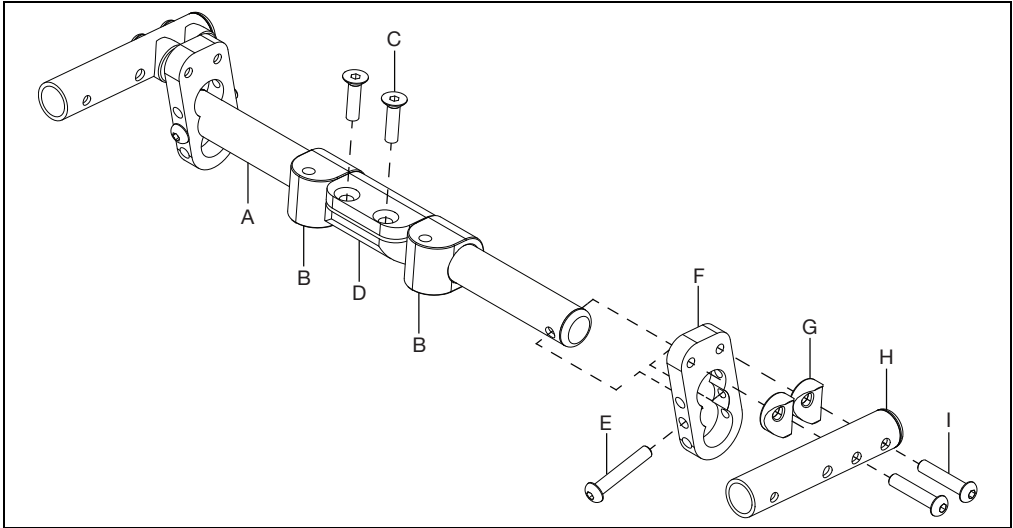

4. Install foot platform (C) onto pivots with two screws (B) using a 5mm Allen wrench. While installing the foot platform, slide the flip foot strap (A) onto frame tube.
5. Install the top and bottom footplate clamps (E & F) onto the footrest tubes and the frame tubes with three screws (D & G) using a 4mm Allen wrench and a 5mm Allen wrench.

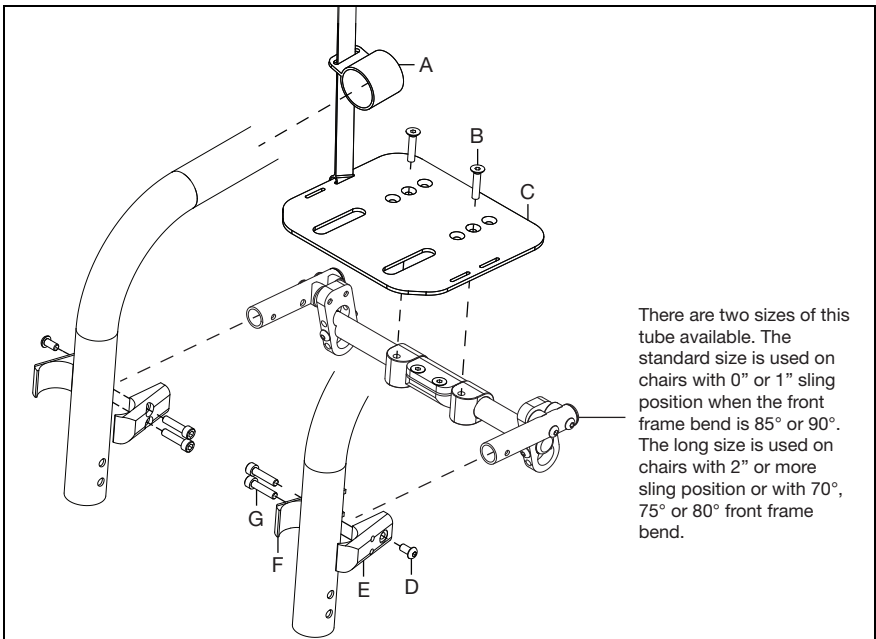

Little Wave Frame Width

1. The Little Wave frame width is changed with the frame connector (C), which is available in 0", 1", 2" and 3" lengths. Remove the four screws (A) and two threaded barrels (B) using two 4mm Allen wrenches to remove the frame connector. Swap in the new frame connector and reinstall hardware to secure.

NOTE: Other parts and assemblies on the chair need to be checked and/or adjusted when the width of the chair is changed. See the corresponding sections on the different parts and assemblies for information regarding installation and adjustments.

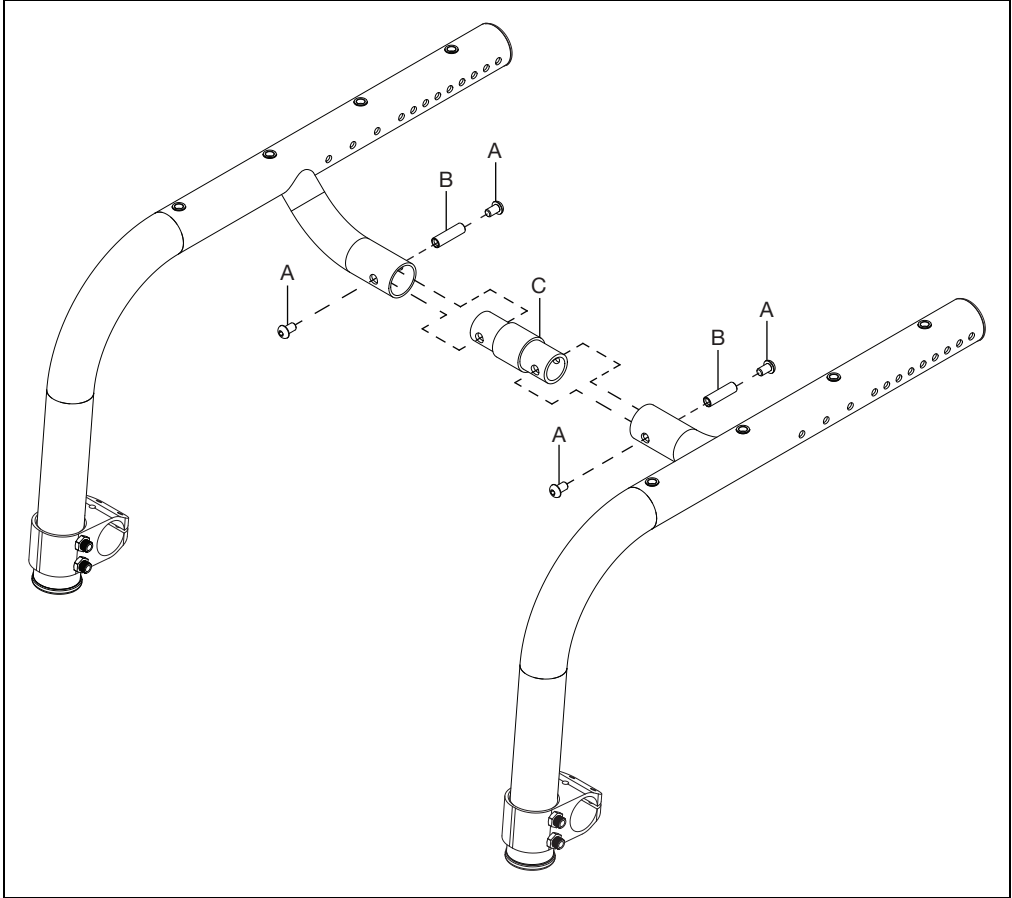

Anti-Tips

1. Assemble the anti-tip by connecting the two anti-tip tubes (B & C) and ensuring they "click" together when the detent buttons (A) engage.

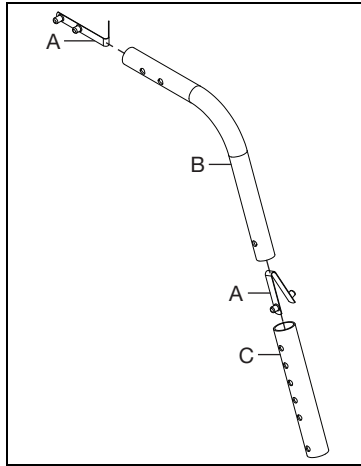

2. Install the wheels (B) onto the anti-tip tube with a bolt (C) and nut (A) using two 10mm wrenches.

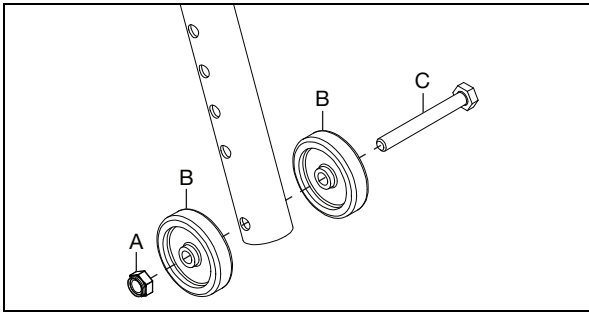

Little Wave Anti-Tip Receiver

1. Install the anti-tip receiver (B) onto the camber tube mounting clamp with two screws (A) and two nuts (C) using a 4mm Allen wrench and an 8mm wrench. Install anti-tip assembly (D) into receiver until detent button "clicks" into place.

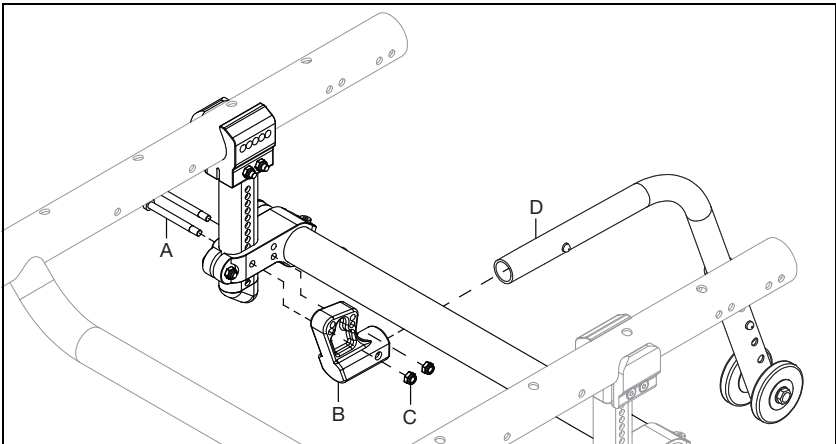

Anti-Tips

Rogue ALX Anti-Tip Receiver

1. Install the anti-tip receiver (C) onto the camber tube and secure with two screws (A) and a threaded barrel (B) using two 4mm Allen wrenches. Repeat on opposite side.
2. Install the anti-tip assembly (D) into receiver until detent button "clicks" into place. Repeat on opposite side.

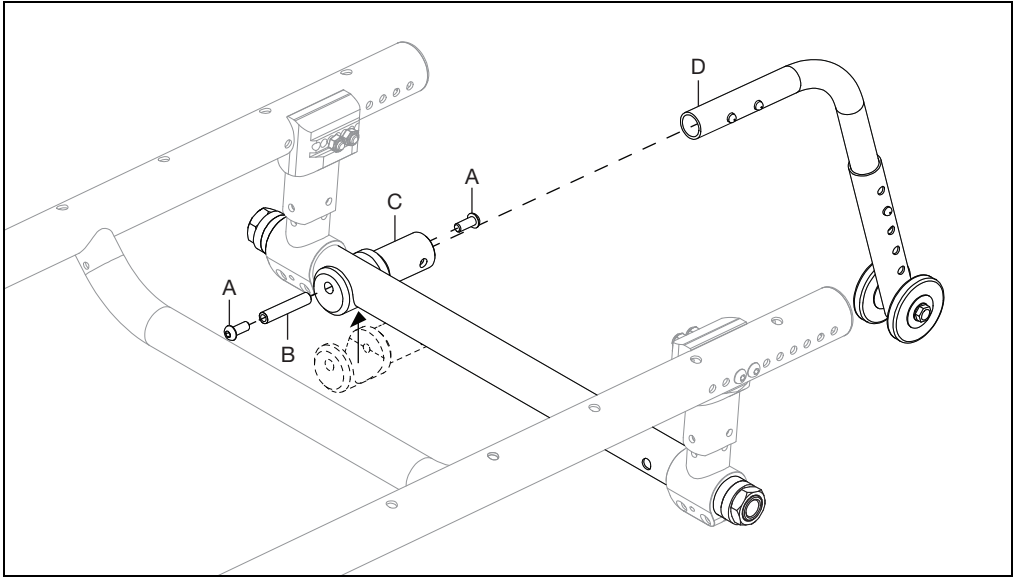

Little Wave 5th Wheel

Standard 5th Wheel

1. Assemble the 5th wheel arm mount as shown below using two ½" wrenches.

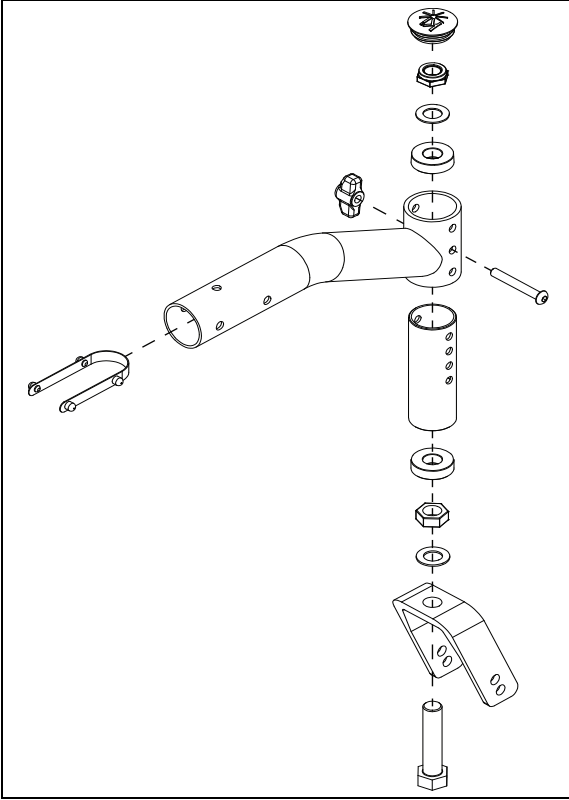

2. Install the caster (D) into the 5th wheel mount forks with two screws (A), threaded barrel (B) and two caster spacers (C) using two 4mm Allen wrenches.

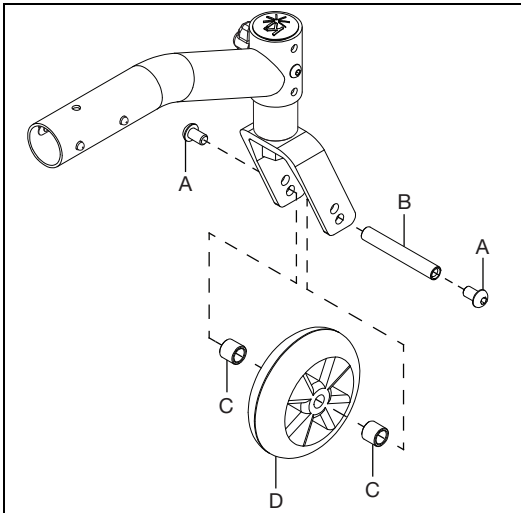

Little Wave 5th Wheel

- Loosen the camber tube mount clamps by removing the bolt (A) and nut (B) from both sides using a 4mm Allen wrench and an 8mm wrench. Slide the camber tube halfway out as shown below. The screws on the camber tube (C) will also need to be removed to clear the clamps using a 4mm Allen wrench.

NOTE: If you are retrofitting to the standard 5th wheel, remove the camber tube completely because a new camber tube is needed.

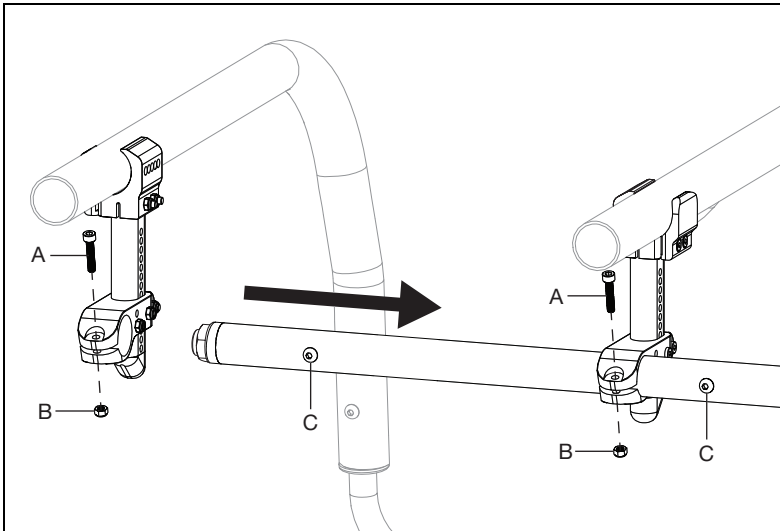

- Slide the 5th wheel mounting clamp (A) onto the camber tube. Slide the camber tube back to the standard position and reinstall hardware to secure the camber tube in place.

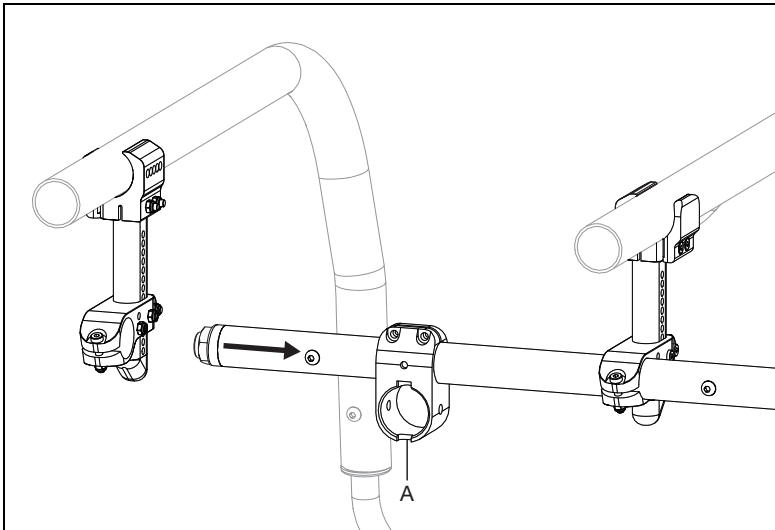

Little Wave 5th Wheel

- Center the 5th wheel mounting clamp and secure in place by installing three screws (A & B) using a 4mm Allen wrench. Install the 5th wheel into the clamp and ensure the detent buttons "click" or lock into place.

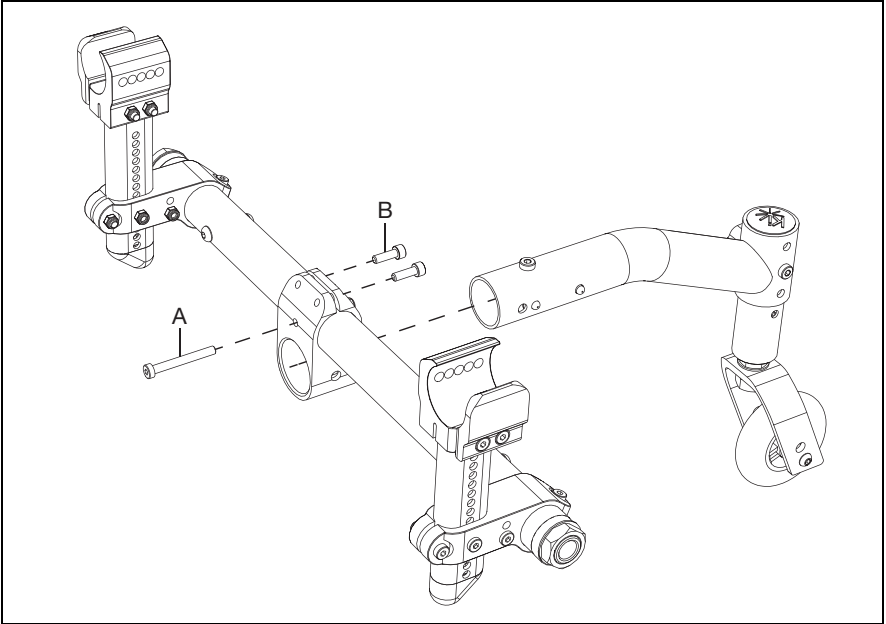

Wheel Locks

See image below for information on the types of wheel locks available. Installation of the wheel lock clamps is on the next page. The Under Seat Scissor Lock always comes assembled so it is not shown below.

Push to Lock Flush Mount

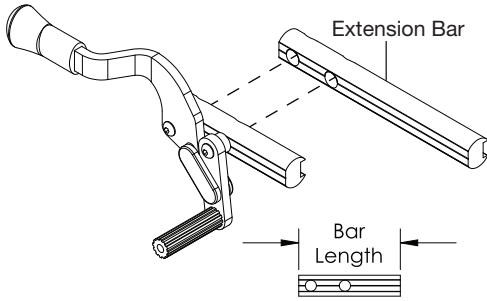

Part #	Bar	Length
N/A	Standard	3.5"
000904	Extended	6.0"

Low Profile Scissor Lock

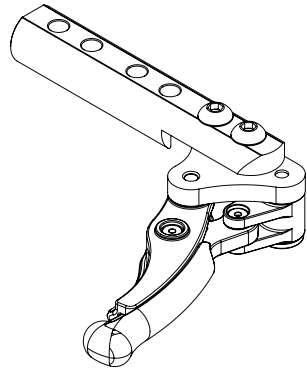

Short Thro Scissor Locks

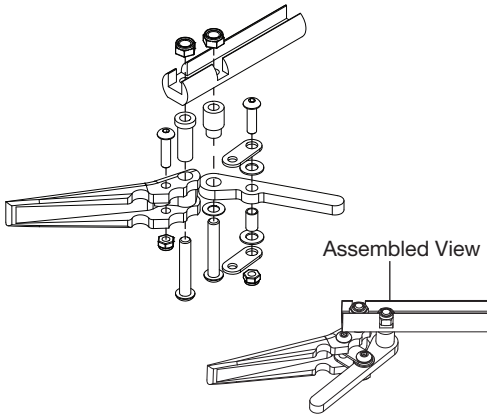

Grade Aids

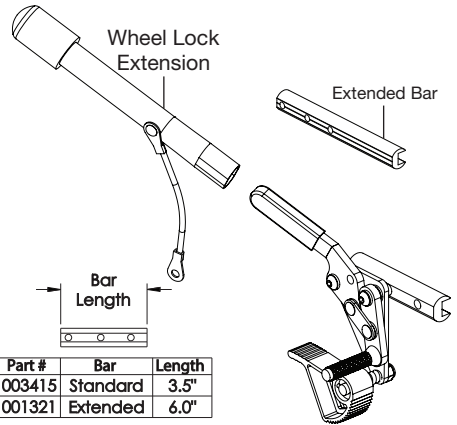

Part #	Bar	Length
003415	Standard	3.5"
001321	Extended	6.0"

Push and Pull to Lock Wheel Locks

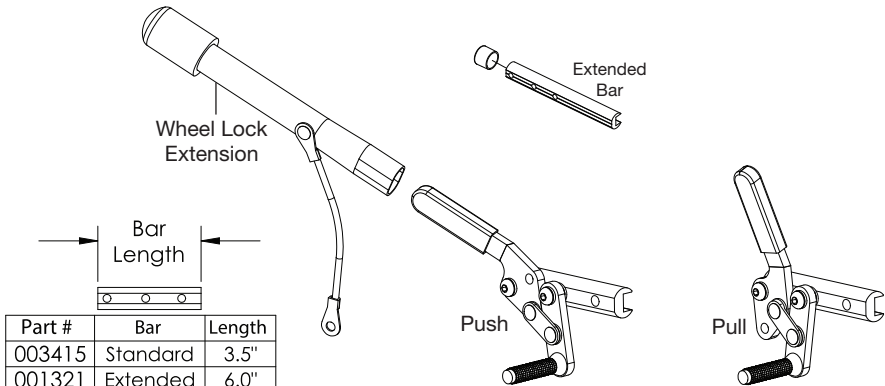

Part #	Bar	Length
003415	Standard	3.5"
001321	Extended	6.0"

Wheel Locks

Installing Wheel Lock Clamps

1. The wheel lock assemblies with the wheel lock bars are mounted onto the chair using the wheel lock clamps (C & D). There are two types of wheel lock clamps that are shown below. Install hardware with the wheel lock bar and chair frame in position using a 5mm Allen wrench and a 6mm Allen wrench. Once installed, ensure wheel lock engages at least 1/8" into tire and locks properly prevent the chair from moving when engaged.

NOTE: Always tighten wheel lock hardware by alternating between hardware while tightening a little at a time. This prevents overclamping on one set of hardware which can lead to binding of the fasteners and increased difficulty in removal.

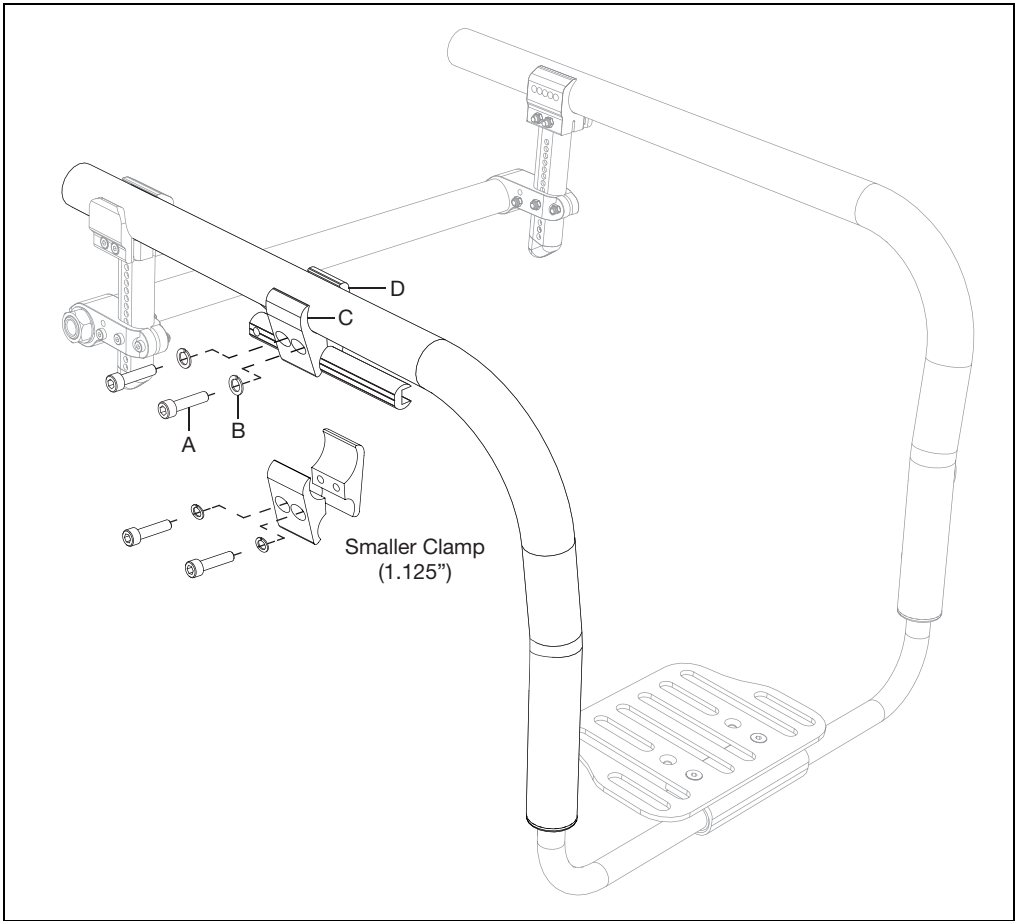

Drum Brake

NOTE: Remove wheels and axle sleeves before beginning the drum brake instructions.

1. Install the drum brake adapter (F) to the drum brake rotor (E) with bolt (A), washer (B) and nut (G) using two 10mm wrenches. Thread the pinch bolt (C) into the drum brake arm.
2. Install the drum brake rotor assembly to the axle plate with axle receiver nut (D), axle sleeve (H), camber adapter (I), two bolts (J) and threaded barrel (K) using two adjustable wrenches and two 5mm Allen wrenches.

NOTE: The drum brake orientation varies depending on the camber tower position. See the diagrams below for additional information.

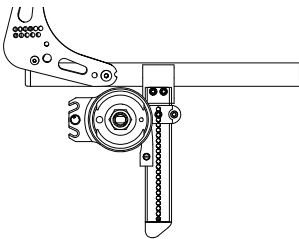
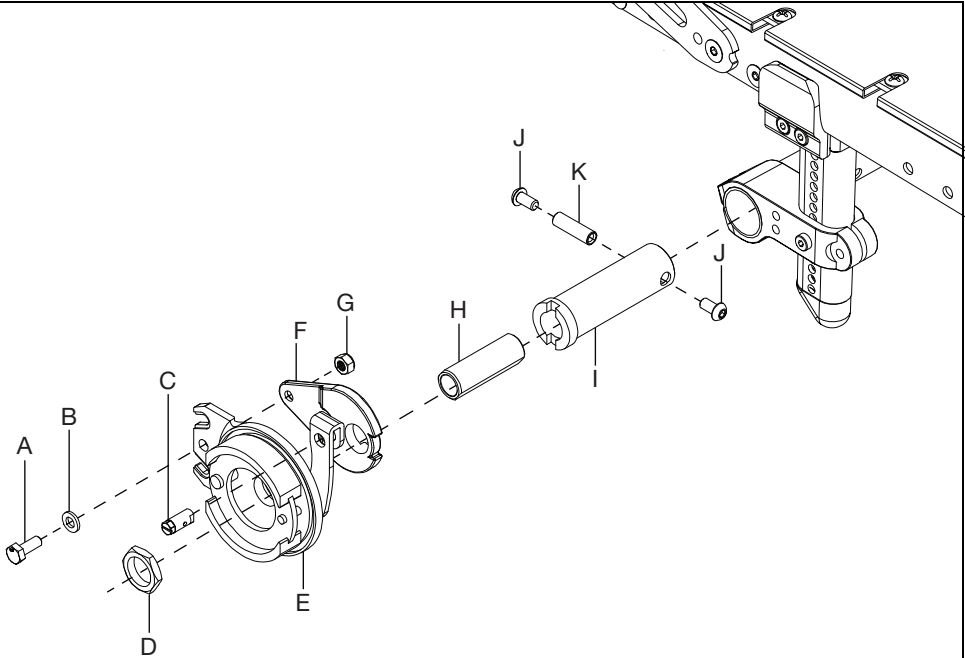

TOWER 000925
CABLE EXITS DOWN

USE WHEN 14 OR
MORE HOLES
EXPOSED BELOW THE
CLAMP

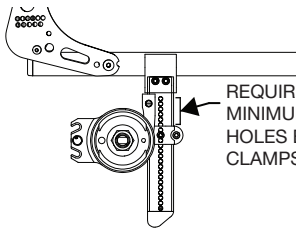

TOWER 000925
CABLE EXITS UP

USE WHEN 13 OR
FEWER HOLES
EXPOSED BELOW THE
CLAMP

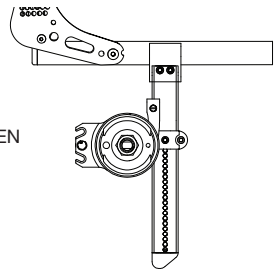

TOWER 000926
CABLE EXITS UP
ALL HOLE POSITIONS

Drum Brake

3. Install the cable to the trigger lever (D) by removing the lever from the mount and removing the cable core from the cable jacket and routing it through the rearmost hole in the lever. Replace the lever and thread the core back through the cable jacket.
4. Install trigger lever (D) and extension adapter (E) to the back post handle with four screws (A & C) and threaded barrel (B).
5. Install the tube end plug (F) on the back of the extension adapter.
6. Install the push handle grip (G) onto the extension adapter.

NOTE: Cable usage based on the configuration is shown in the tables below the image.

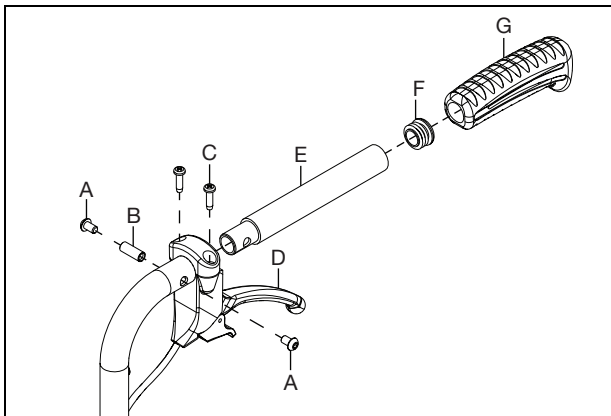

Cable Size for Backrest Type

		Fixed Height	Height Adjustable	
			Ex Short & Short	Medium & Tall
Backrest Height	9	4XS	3XS	
	10	4XS		
	11	3XS		
	12	3XS		
	13	3XS		
	14	3XS	2XS	
	15	2XS		
	16	2XS		
	17	2XS		
18	2XS			

Drum Brake

7. Route the cable down the backrest cane to the drum brake.
8. Thread the end of the the cable through the hole in the pinch bolt and tighten after removing all play from the cable.
9. Adjust cable until no wheel drag is present and positive lock is achieved with levers.
10. Secure cable to back cane and frame with cable clip (A) and P-Clip (B) as shown.

NOTE: The image below shows a Rogue XP. The cable routing and placement of clips is the same for the Rogue ALX.

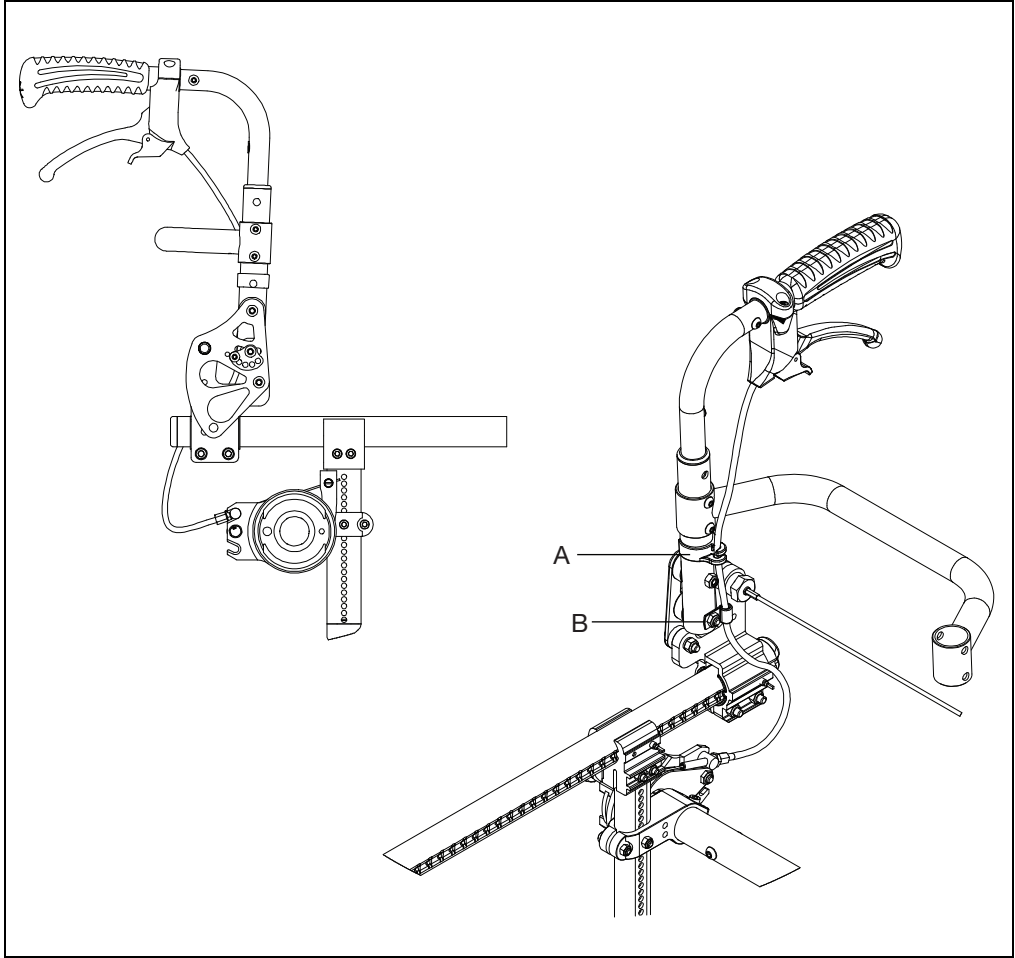

Caster Flutter

CASTER FLUTTER: Caster flutter is when the front casters start to move uncontrollably from side to side as the wheel rolls forward.

COMMON CAUSES: High speeds, misalignment of caster to ground and looseness in the caster/fork/stem assembly.

1. Check to make sure all fasteners in the caster, fork and stem assembly have been appropriately tightened down and that there is no excessive play between any of the parts. The hardware that needs to be checked is called out in the image below and the tools needed for each bolt are in the table below. Check for caster flutter. If still present, move to the next step.

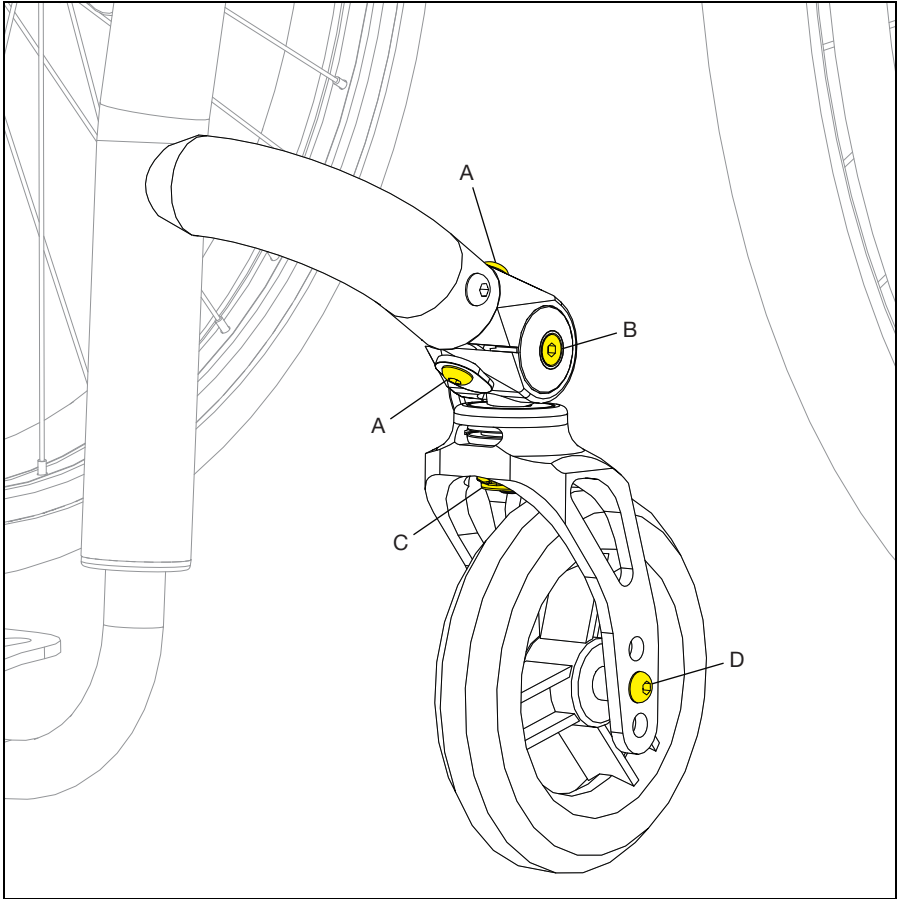

A - Two 4mm Allen wrenches needed for tightening/adjustment.	B - Two 3mm Allen wrenches needed for tightening/adjustment.	C - A 19mm or 3/4" socket wrench needed for tightening/adjustment.
D - Two 4mm Allen wrenches needed for tightening/adjustment		

Caster Flutter

2. Check to make sure casters are square and there is no caster float (caster doesn't or barely touches the ground) while seated in the chair.

Adjusting the Caster Angle:

- a. Loosen the bottom screw (A) and turn the top screw (A) of the caster housing wing. Loosening will begin to tilt the caster forward. By tightening, you will turn the caster rearward.
- b. Loosen or tighten until you align the caster stem so it is perpendicular to the floor.
- c. Place a large right triangle against the flat surface of the fork, as shown below.
- d. Test for caster flutter. If still present, continue to the next step.

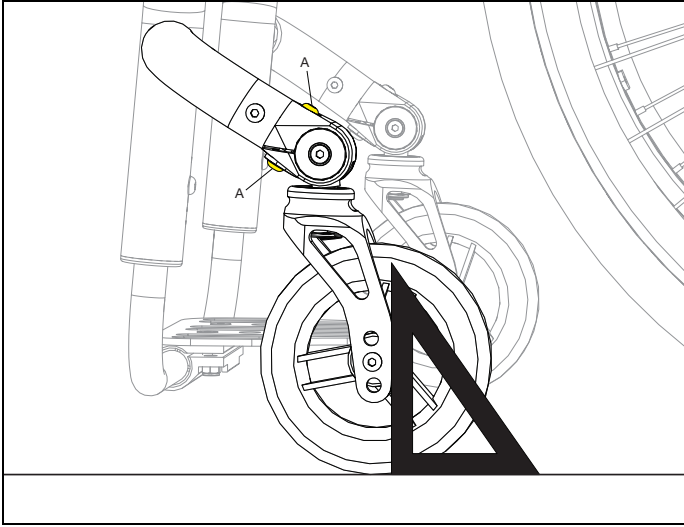

3. Open caster angle by adjusting the caster toward the front of the chair by one degree. Check for flutter. If still present, add another degree. Continue to do this until you reach three degrees. It is not recommended to open the caster angle beyond three degrees.

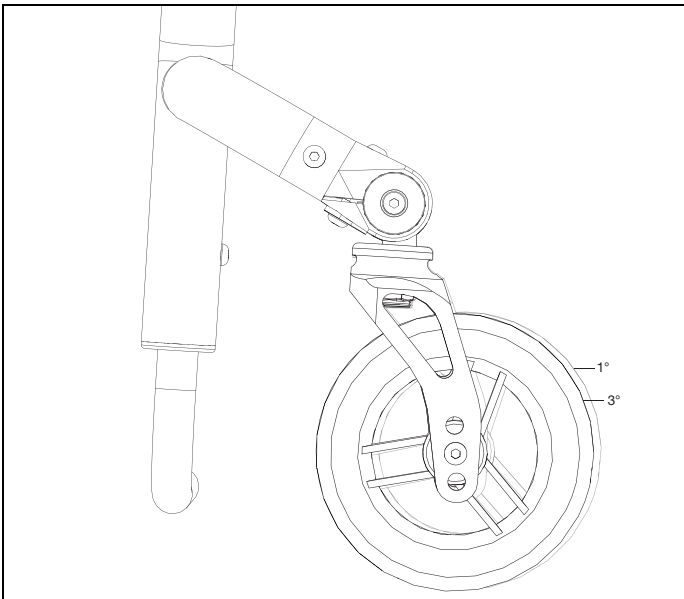



Ki Mobility
5201 Woodward Drive
Stevens Point, Wisconsin 54481
715-254-0991
www.kimobility.com



DCN0577.4