

**THIS TECHNICAL MANUAL HAS BEEN DEVELOPED FOR AND
INTENDED TO BE USED BY A QUALIFIED TECHNICIAN
WORKING FOR AN AUTHORIZED KI MOBILITY DEALER.**

ROGUE & ROGUE

TECHNICAL MANUAL



WARNING

WARNING: Repairs and adjustments not made by a qualified technician working for an authorized Ki Mobility Dealer can result in poor performance or failure of the device which may cause serious injury or death.

This technical manual is designed to aid in the different procedures that may be needed for the Rogue and Rogue XP wheelchairs. This technical manual does not replace, but aids the user instruction manual, adjustment guides and instructions. The procedures shown in this technical manual should only be performed by an Assistive Technology Practitioner (ATP) or clinical professional trained to do wheelchair repairs, adjustments and retrofits.

Additional information can be found in the Rogue and Rogue XP User Instruction Manual. The user instruction manuals can be found on the Ki Mobility website.

If you have any questions or concerns about any aspect of this wheelchair, this manual, or the service provided by us or your retail supplier, please do not hesitate to contact us by telephone at:

715-254-0991

In writing at:

Ki Mobility
5201 Woodward Drive
Stevens Point, WI 54481
U.S.A

Via email at:

sales@kimobility.com

Or via our Authorized EU Representative:

Etac Supply Center AB
Långatan 12
33233 Anderstorp
Sweden

Table of Contents

Tools.....	3
Frame Tube Size Guide.....	3
Spoke Tension Values.....	3
Chair Measurement References.....	4
Caster Mount	5
Caster Forks and Stems	6
Caster Angle and Squaring	12
Camber Mount Assembly	13
Camber Tube and Adapters.....	15
Backrest Assembly - Rogue	16
Backrest Assembly - Rogue XP.....	19
Height Adjustable Back Post	21
Fixed Height Back Post	22
Rigid Stroller Handle	23
Ergo Stroller Handle - Available on Rogue XP	23
Bolt-On Push Handle	24
Height Adjustable T-Arm.....	25
Angle Adj. Locking Flip Up Extendable Armrest - Available on Rogue XP	26
Swing Away Armrest - Available on Rogue.....	27
Swing Away Armrest - Available on Rogue XP	28
Cane and Crutch Holder	29
Luggage Carrier	30
Handrim Configurations	31
Handrim Construction.....	32
Seat Pan.....	33
Seat Upholstery.....	34
Side Guards	35
Transit	39
Angle Adjustable Footrest.....	41
Angle Adjustable Flip Under Footrest	42
High Mount Angle Adjustable Footrest	43
High Mount Angle Adjustable Flip Under Footrest	44
Adjusting the Footrest.....	45
Rogue XP Frame Width.....	45
Anti-Tips.....	46
Rogue XP 5th Wheel.....	47
Wheel Locks.....	54
Reversing Wheel Lock	56
Center of Gravity Adjustment.....	59
Seat Height Adjustment	60
Setting Toe to Zero	61
Wheelbase Width Adjustment.....	62
One Arm Drive (OAD)	63
Growing Your Rogue XP in Width.....	68
Drum Brake	69
Caster Flutter	72

Tools

Please see the list below to identify the tools needed throughout this tech manual. Always check tools to ensure the ends are not stripped and that the tool can perform its function properly without damaging any parts or hardware on the chair.

Tools Needed		
• 2.5mm Allen Wrench	• Two 8mm Wrenches	• Utility Blade
• 3mm Allen Wrench	• Two 10mm Wrenches	• Torque Wrench
• 4mm Allen Wrench	• 13mm Wrench	• Rubber Mallet
• 5mm Allen Wrench	• 17mm Wrench	• Phillips Screwdriver
• 5.5mm Allen Wrench	• 19mm Wrench	• Punch (or small screwdriver)
• 6mm Allen Wrench	• 24mm Wrench	

Frame Tube Size Guide

Tubing sizes subject to change without notice

This information is a reference for situations where the tube sizes are needed for certain attachments.

Rogue Frame Tube	Rogue XP Frame Tube
Frame Tube: 1 3/8"	Frame Tube: 1 3/8"
Camber Tube: 1 1/8"	Camber Tube: 1 1/8"
Back Canes	Back Canes
Fixed Height Back Canes: 1"	Fixed Height Back Canes: 1"
Rigidizer Bar: 7/8"	Rigidizer Bar: 7/8"
Lower Height Adjustable Back Tube: 1"	Lower Height Adjustable Back Tube: 1"
Upper Adjustable Upper Back Tube: 3/4"	Upper Adjustable Upper Back Tube: 3/4"
Half Folding Back: 7/8"	
Arms	Arms
Swing Away: 1"	Swing Away: 1"
Upper T-Arm: 7/8"	Upper T-Arm: 7/8"
Transfer Tube T-Arm: 3/4"	Transfer Tube T-Arm: 3/4"
Angle Adjustable Flip Up: 1"	Angle Adjustable Flip Up: 1"
Footrests	Footrests
Footrest Tubes: 3/4"	Footrest Tubes: 3/4"

Spoke Tension Values

OAD Spoke	60-100 kgf
Drum brake Spoke	90-120 kgf radial side / 60-90 kgf crossed side
Maxx Spoke	60-100 kgf
Low Cost Spoke	60-100 kgf
Spinergy	Contact Spinergy for more information

Chair Measurement References

The Rogue and Rogue XP wheelchairs are capable of many adjustments to configure the chair to the user's needs. See the diagram below for terms that are commonly used during the process of adjusting the chairs.

A. Seat Width (see diagram 1)

Measured from outside of frame tube on one side to the outside of frame tube on the other side.

B. Seat Depth (see diagram 3)

Measured from front of back posts to front edge of seat sling. Seat sling starts at beginning of bend at front of frame.

C. Sling Position (see diagram 2)

In Performance Position (0°), sling is at front of frame to keep chair shorter and more maneuverable. The 1" or 2" seat sling position extends the frame in front of the sling by that amount. Adding more frame can improve stability and provide support to aid in transfers.

D. Front Frame Bend (see diagram 3)

Angle between front seat tube and ground.

E. Footrest Taper (see diagram 1)

Indicates bend of front frame creating footrest. Taper is measured from outside of seat frame to outside of front tube.

F. Front Seat Height (see diagram 1)

Measured from floor to top of seat tube at front of seat sling.

G. Footrest Width (see diagram 1)

Measured from inside of front tube to inside of front tube on other side. Footrest width is listed below for each seat width and taper.

Seat Width Outside Measurement	Straight		2" Taper	
	2" Narrower than Seat Width	4" Narrower than Seat Width	6" Narrower than Seat Width	8" Narrower than Seat Width
12"	9.5"	7.5"		
13"	10.5"	8.5"		
14"	11.5"	9.5"		
15"	12.5"	10.5"		
16"	13.5"	11.5"	9.5"	
17"	14.5"	12.5"	10.5"	
18"	15.5"	13.5"	11.5"	
19"	16.5"	14.5"	12.5"	
20"	17.5"	15.5"	13.5"	

H. Seat to Footrest Length (see diagram 3)

Measured from front edge of seat sling to top rear of footrest. Footrest length of at least 2.5" shorter than front seat height recommended.

I. Rear Seat Height (see diagram 3)

Measured from floor to top of seat tube at front of back post. Rear seat height is custom to needs.

J. Center of Gravity Preset (see diagram 3)

Measured from front of back post to center of rear axle. 0" indicates axle will be directly under back post.

K. Rear Wheel Spacing (see diagram 1)

Measured from outside of seat back to inside of rear tire. Adjustable out .5" from setting.

Diagram 1

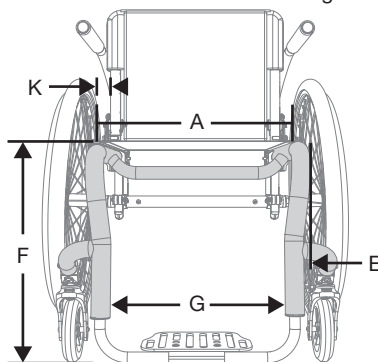

Diagram 2

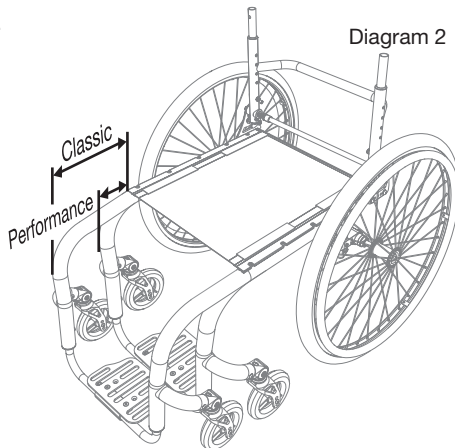
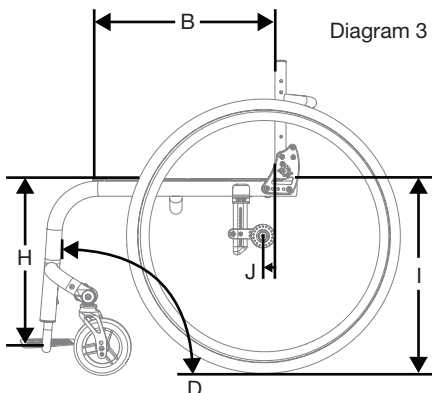
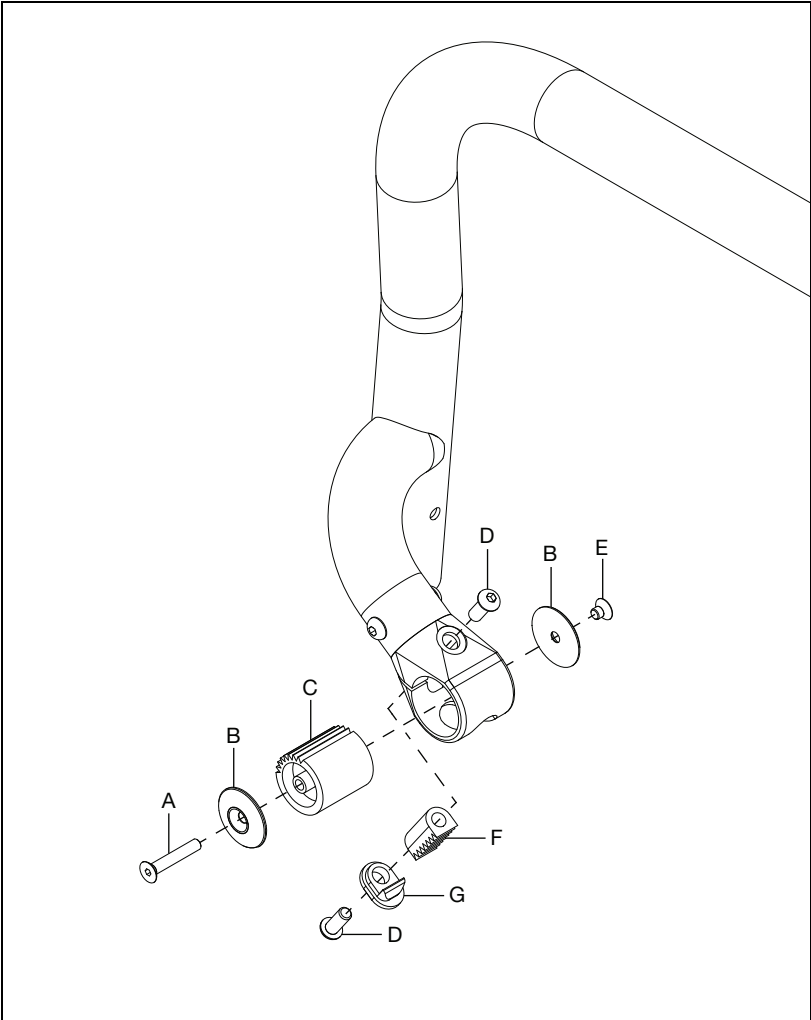

Diagram 3



Caster Mount

1. Install the caster mount pinion (C) into the caster mount housing with the two caster pinion caps (B) with two screws (A & E) using two 3mm Allen wrenches.
2. Install the caster adjust (F) and the pinion housing bolt plate (G) with the two screws (D) using two 5mm Allen wrenches.



Caster Forks and Stems

Remove Caster Fork and Stem

1. Remove bottom nut and washer using a 19mm or 3/4" socket wrench. Remove fork assembly.

NOTE: Based on your configuration, the caster may need to be removed first to allow clearance for wrench (See step 3).

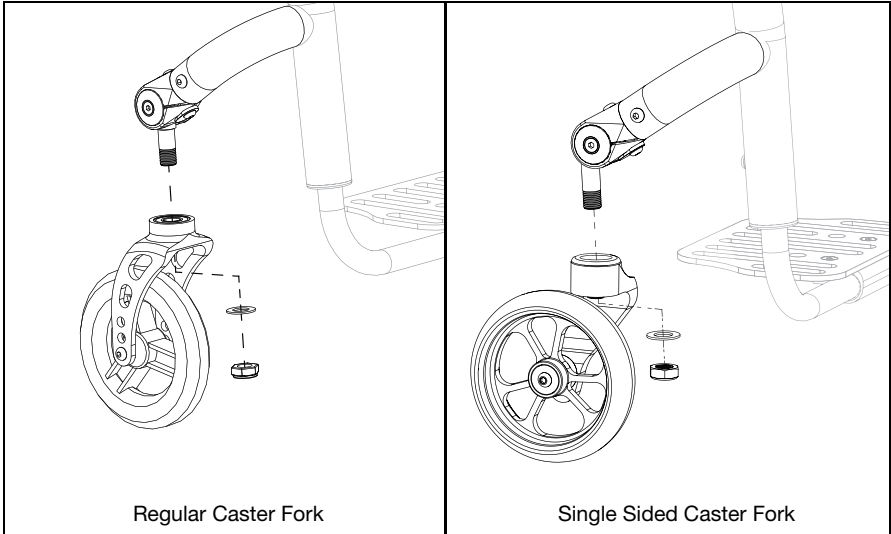

2. Remove two socket screws using two 3mm Allen wrenches and remove stem. Save hardware for later use. Save the stem if you are not replacing stem.

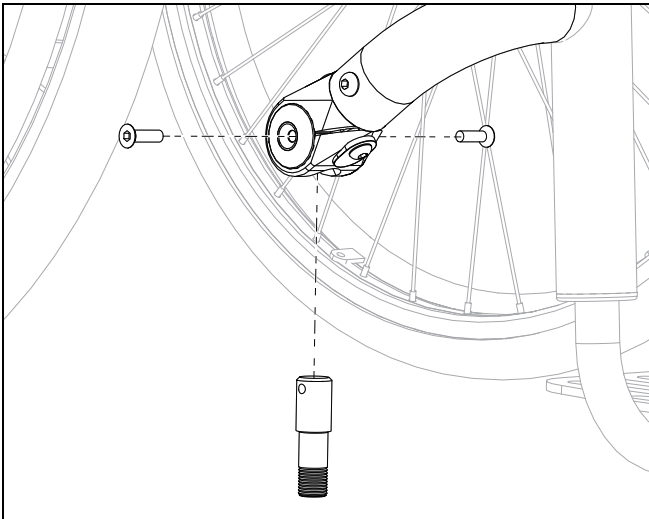

Caster Forks and Stems

3. If you are replacing your forks continue for instructions. For a regular caster fork, remove caster wheel by removing two socket head screws and two spacers using two 4mm Allen wrenches. For a single sided fork, remove the socket head screw, axle shaft and E-Clip using a 5mm Allen wrench.

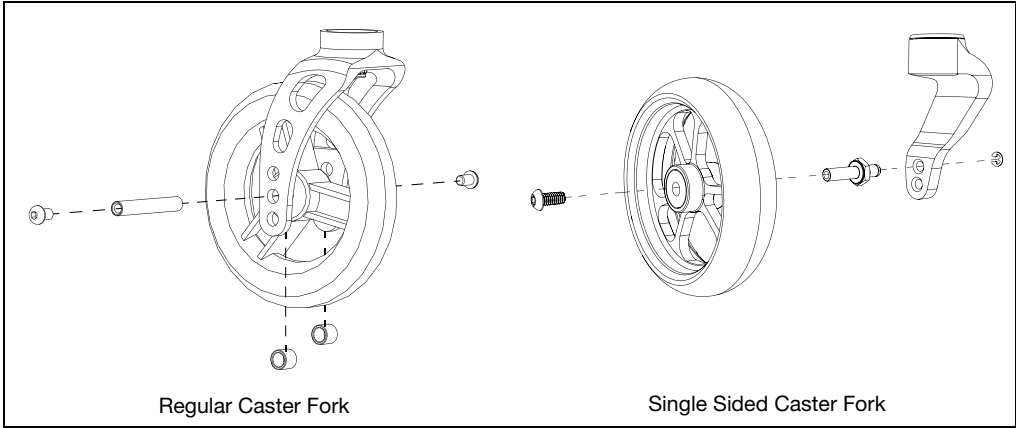

Install Caster Fork and Stem

1. Install stem (A) into fork (B) with washer (E) and nut (F) using a 16mm wrench.
2. Install caster wheel (H) into fork (B) with two screws (C), a threaded barrel (D) and two spacers (G) using two 4mm Allen wrenches.

NOTE: There are two sizes of caster stems (standard and +3/4") and three sizes of forks (tall, standard and short) that can be used. The image below shows the stems and forks. The installation process is the same for whichever stem and fork you use.

3. Install assembly to caster housing by installing the two socket screws seen in step 2 on previous page.

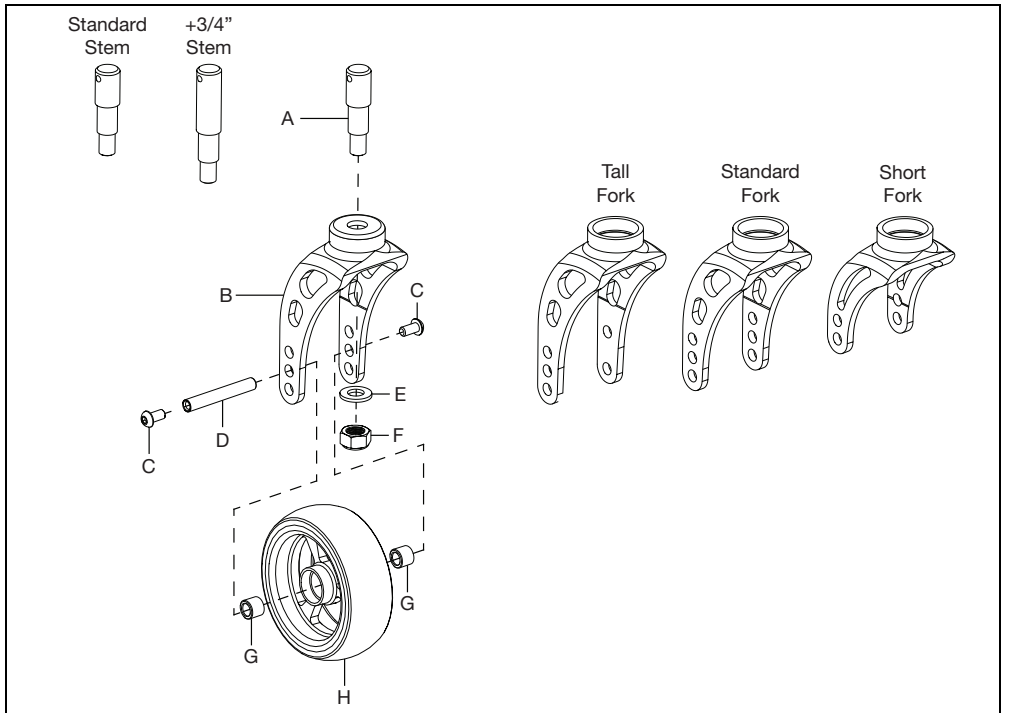

Caster Forks and Stems

Single Sided Fork

1. Install stem (A) into single sided fork (B) with washer (C) and nut (D) using a ½" wrench.
2. Install caster wheel (F) onto fork (B) with a screw (E), the axle shaft (G) and secure with E-Ring (H).

NOTE: There are two sizes of caster stems (standard and +3/4") and two sizes of forks (short and tall) that can be used. The installation process is the same for whichever stem and fork you use.

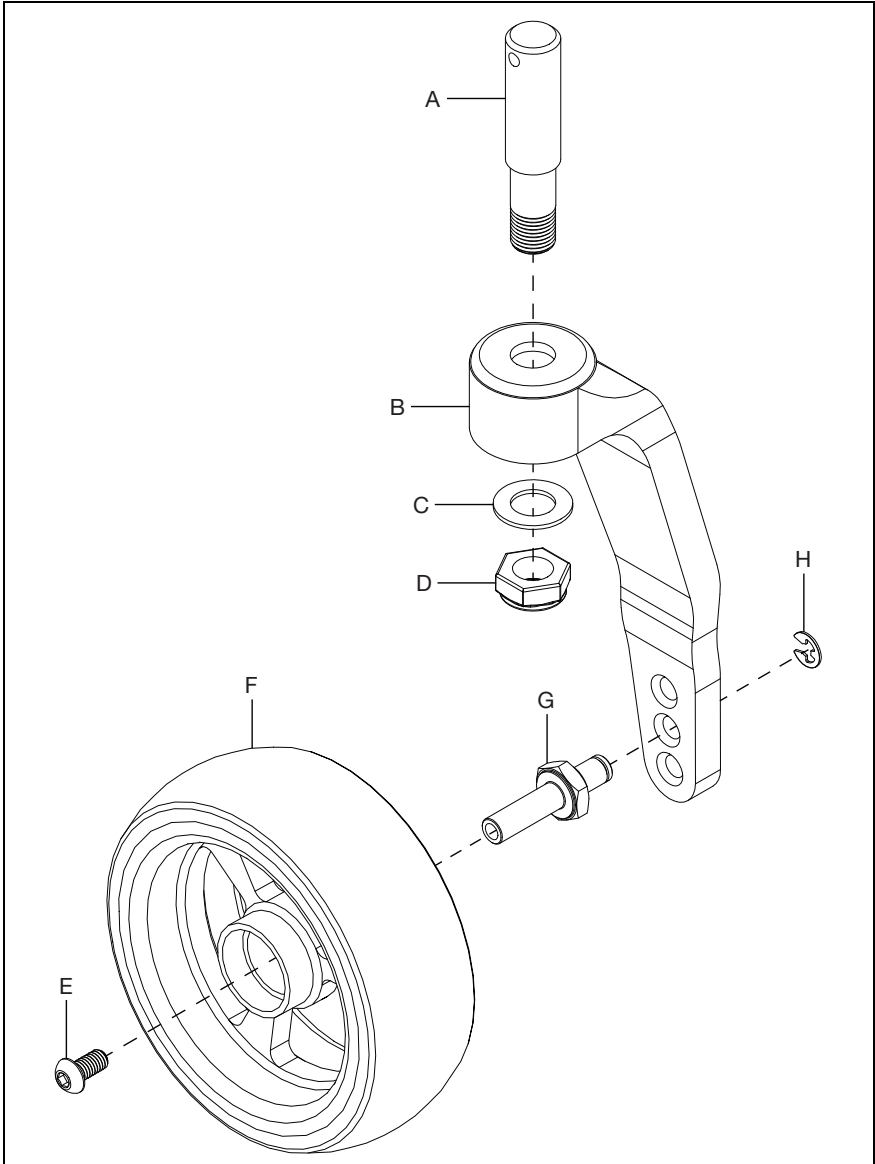

Caster Forks and Stems

Frog Legs Ultra Sport Fork Assembly

1. Install Frog Leg Ultra Sport Fork (A) onto caster wheel (E) with axle (B), screw (C) and two spacers (D) using two 4mm Allen wrenches.

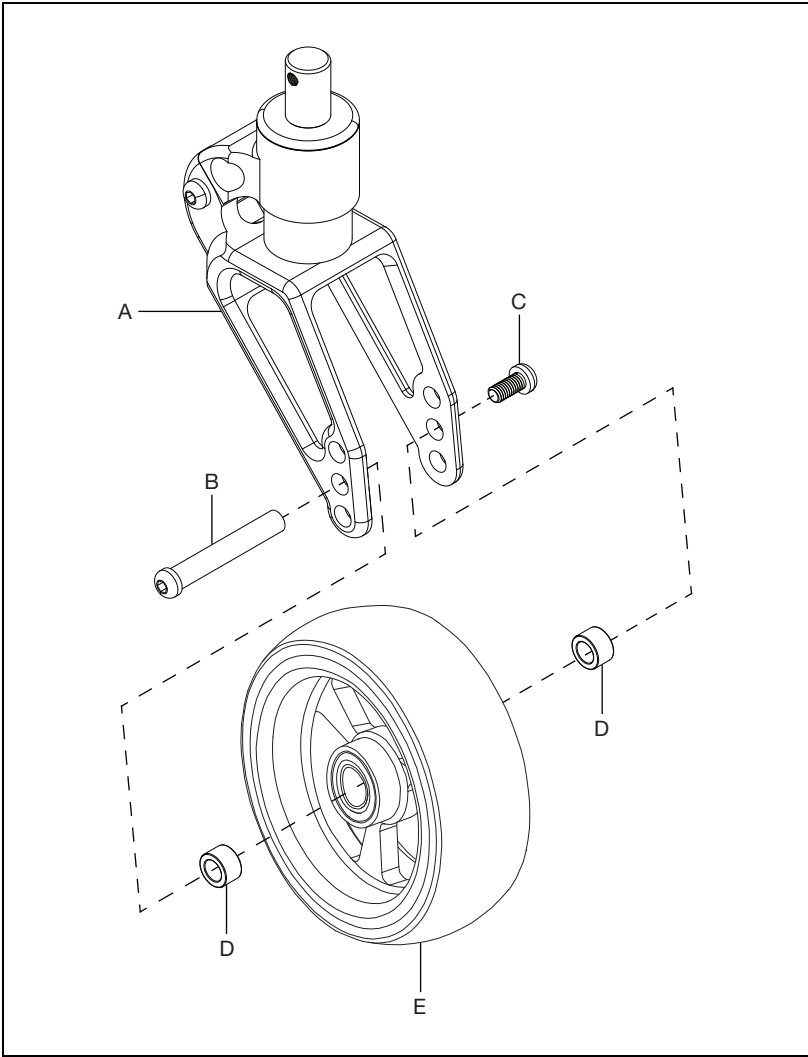

Caster Forks and Stems

Frog Legs Phase 2 Carbon Fork Assembly

1. Install Frog Leg Phase 2 Carbon Fork (A) onto caster wheel (E) with axle (B), screw (C) and two spacers (D) using two 4mm Allen wrenches.

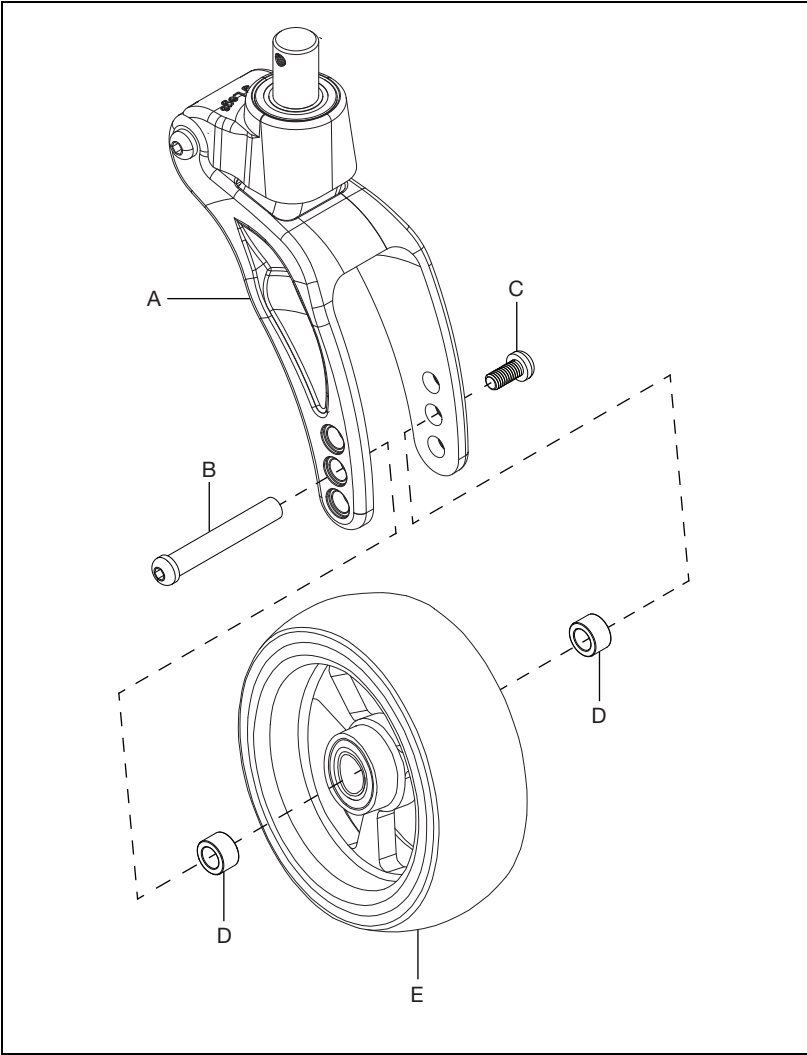

Caster Forks and Stems

Frog Legs Ultra Sport Fork Polymer Replacement

NOTE: The Ultra Sport fork has different polymers that can be used based on the chair user's weight and preferred ride. The Phase 2 fork has one polymer that works for any configuration. If ever needed, the replacement procedure is the same for a Phase 2, but no coin is needed.

1. Remove the pivot pin screw (D) using a 4mm Allen wrench.
2. Use a punch or small screwdriver and a rubber mallet to push the pivot pin (A) out.
3. Open the fork assembly and remove the polymer (C) and coin (B).
4. Install the new polymer (C) and coin (B).
5. Insert the pivot pin (A) back into the fork assembly. A punch or small screwdriver can be used to help align holes if needed.
6. Secure the assembly by reinstalling the pivot pin screw (D) using a 4mm Allen wrench.
7. Repeat steps on opposite side.

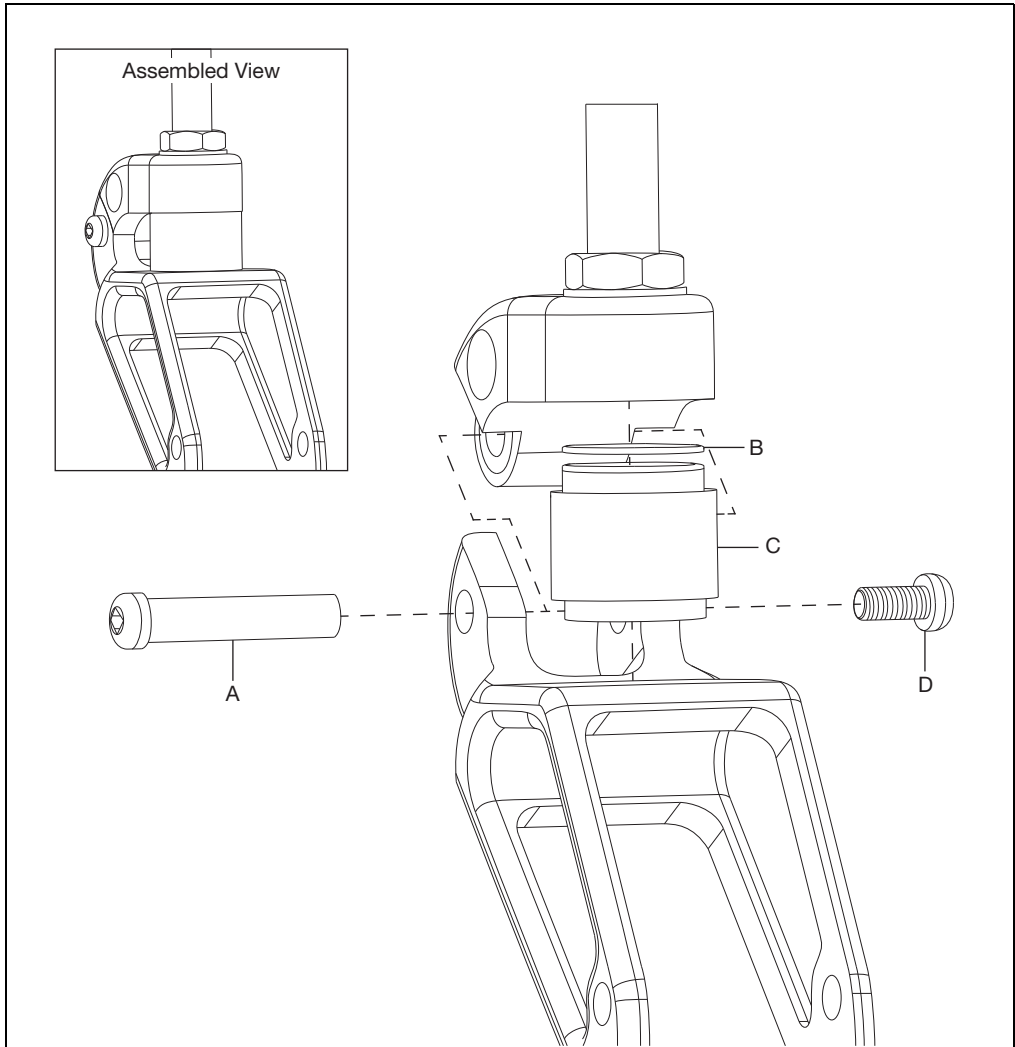

Caster Angle and Squaring

To maintain optimal performance of your Rogue, the front caster housing should always be aligned perpendicular to the ground. Your Rogue is shipped aligned. It is recommended that caster squareness is checked after making adjustments to the chair configuration related to any of the following items: caster size or type, camber, rear wheel, tire, center of gravity and seat heights. Caster squareness should always be the last check made prior to use after adjustments or changes to the chair have been made.

After all other adjustments are made you should check your caster housing alignment and realign if the housing is not perpendicular to the ground.

Adjusting the Caster Angle:

For optimum performance, the caster housing should always be at 90° angle to the floor (perpendicular to the ground).

1. To change the angle, you will need an M5 Allen wrench.
2. Loosen the M8 button head screw (A) on the bottom of the caster housing wing. Turn the screw on the top of the caster housing wing (B). Loosening will begin to tilt the caster forward. By tightening, you will turn rearward.
3. Turn until you have aligned the caster stem so it is perpendicular to the floor.
4. Place a large right triangle against the flat surface of the fork as shown.
5. With the rack and pinion system of the Rogue, the casters should always be able to be square.

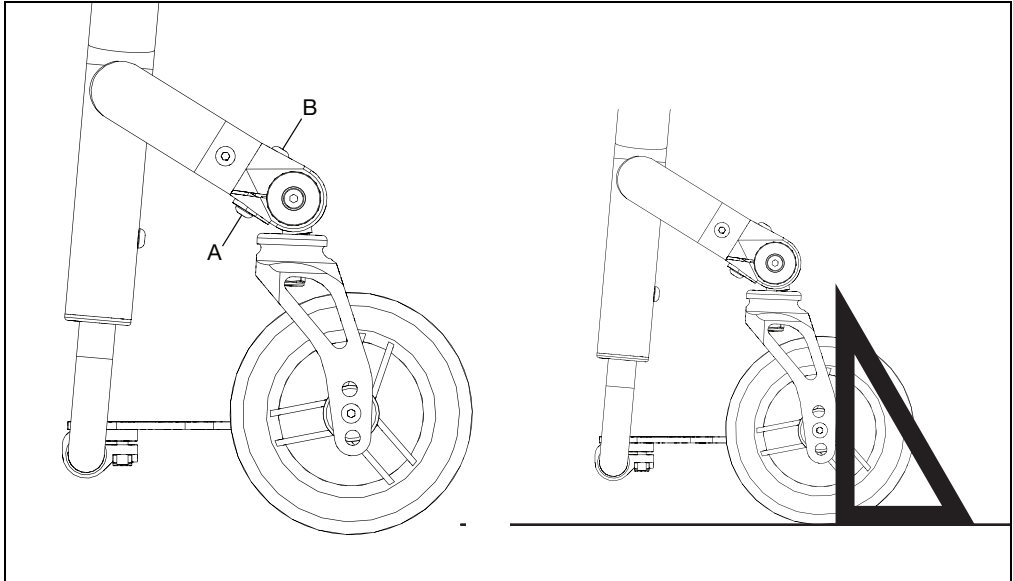

Camber Mount Assembly

NOTE: Install one side at a time so you are able to install the camber tube properly in a later step.

NOTE: The outside clamp (B) is not used when the COG is set at -0.25 or less.

NOTE: In some rare configurations where the seat depth is shallow, arm receivers are present and there is a rare amount of COG, the camber tube clamps are rotated so the camber tube is more forward facing than rear facing. In these instances, call customer service at Ki Mobility.

1. Install the tower clamps (B & C) onto the frame with the camber mount tube (E) and the camber tube cap (F) using two screws (A) and two nuts (D) with a 4mm Allen wrench.

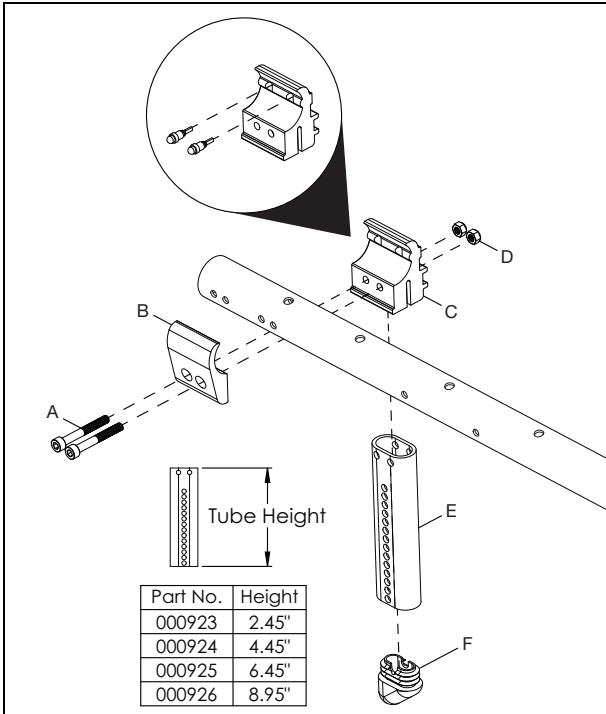

2. Install the camber tube mounting clamp (B) onto the camber mount tube and secure with two screws (A) and two nuts (C) using a 4mm Allen wrench and an 8mm wrench.

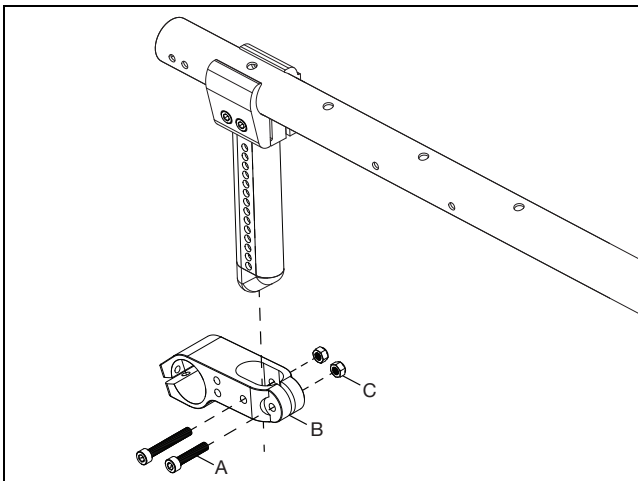

Camber Mount Assembly

3. Install camber tube (D) into the camber tube mounting clamp and secure with screw (B) and nut (C) using a 4mm Allen wrench and an 8mm wrench. Install and tighten the two set screws (A) with a 2.5mm Allen wrench.

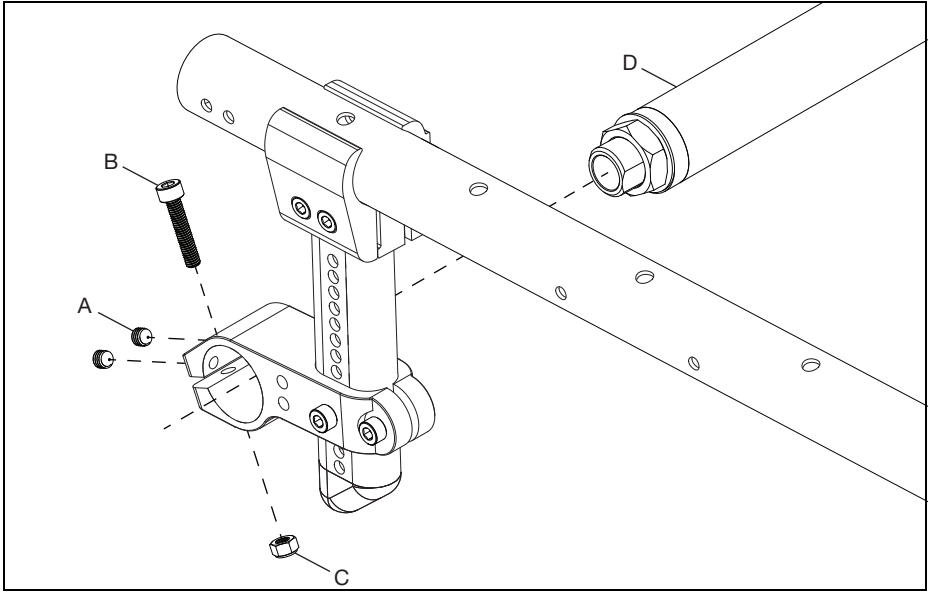

4. Repeat steps on opposite side.

Camber Tube and Adapters

1. Install axle receiver, axle receiver nut, axle plate washer and camber adapter into the camber tube.

NOTE: The camber adapter is available with 0°, 2°, 4°, 6° and 8° camber.

2. Secure the camber adapter into the camber tube with two screws and a threaded barrel using two 4mm Allen wrenches.

3. Repeat steps 1 and 2 on opposite end of camber tube.

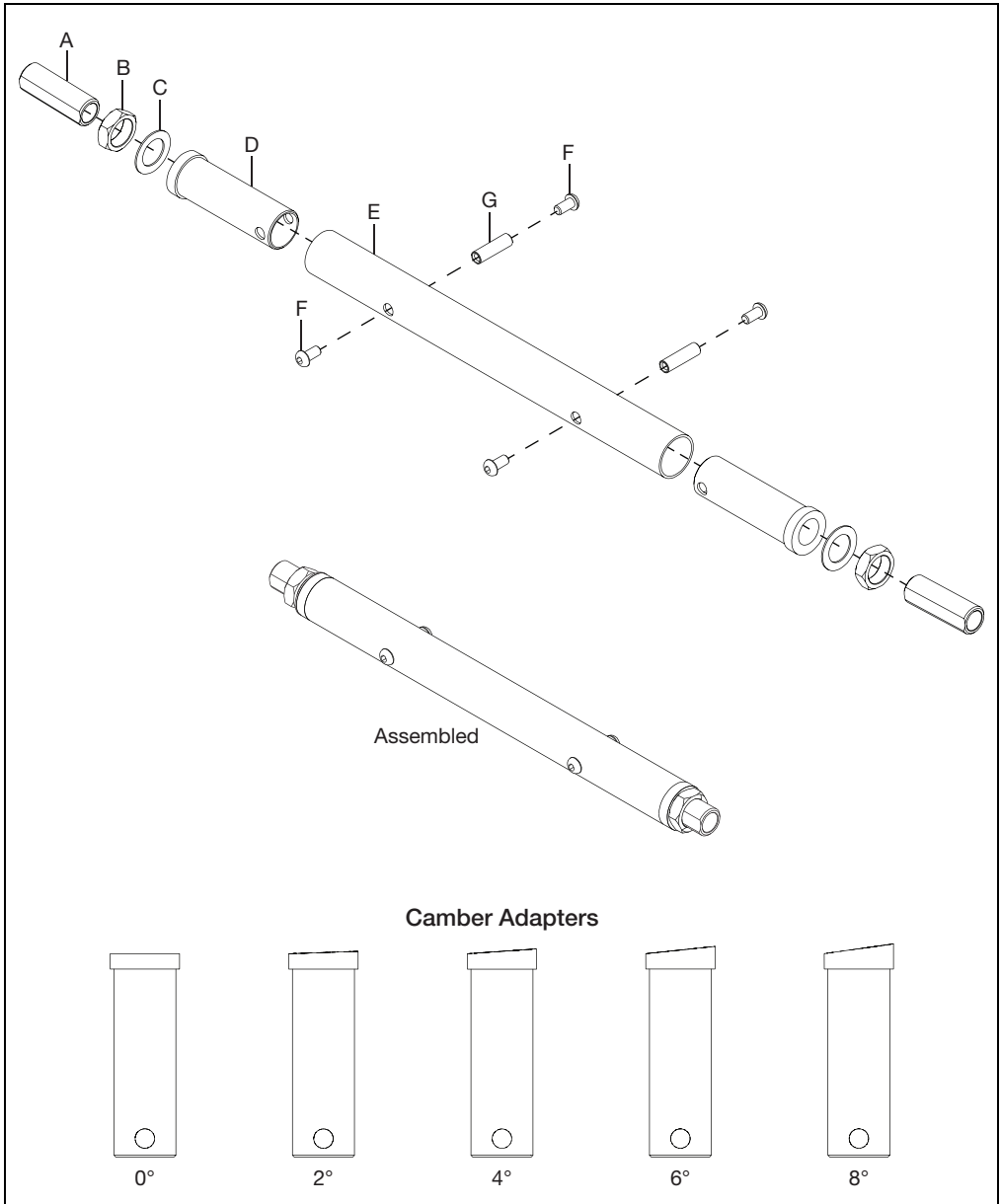

Backrest Assembly - Rogue

Backrest Installation

NOTE: Remove existing backrest before beginning the installation process.

NOTE: If replacing the whole backrest, the backrest will come as an assembly and the first two steps can be skipped.

1. Install the release lever assembly (B) onto the back post (A) with a screw (D) and nut (C) using a 3mm Allen wrench. The screw will pass through the tube sleeve (E) and release pin (G) which are installed up through the bottom of the back post. The compression spring (F) is installed up through the bottom of the back post also, but the bolt doesn't pass through it. Repeat steps on opposite side of back post.

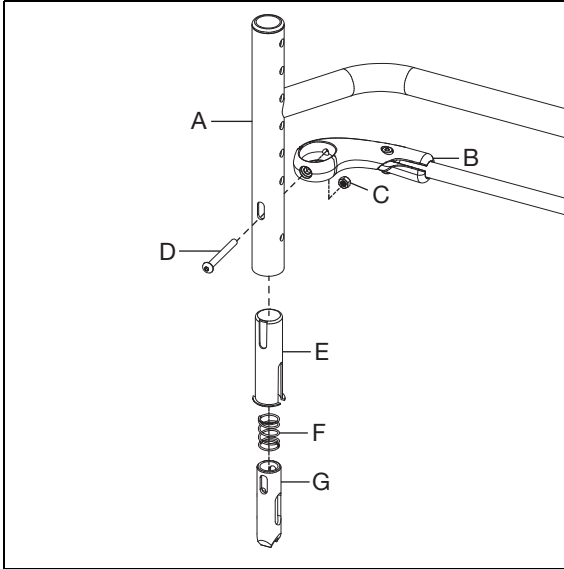

2. Secure the relax bumper (C) to the relax saddle (B) with the screw (A) using a 3mm Allen wrench. There are three index slots that the screw can be installed in - the top (9°), middle (4.5°) and bottom (0°). Install the screw in the desired position and repeat steps on the second set of saddles and bumpers. Ensure both sides are set in the same position.

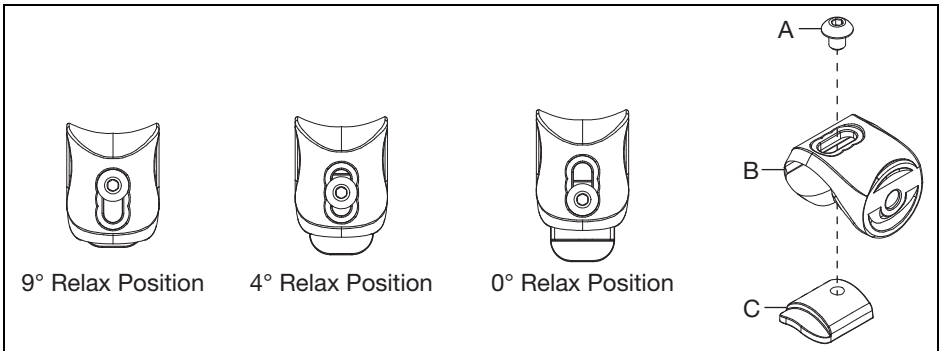

Backrest Assembly - Rogue

3. Secure the new backrest plate (E) to the backrest post with the barrel nut (A) and 3/8" external retaining ring (J) using a pliers.
4. Secure the top of the backrest plate (E) to the backrest post with the shoulder bolt (C), fender washer (K) and nut (L) using a 3mm Allen wrench and an 8mm wrench.
5. Install the adjustment screw plug cap (B) through the backrest plate. Install the bolt (F) in through adjustment screw plug cap (B) and secure by installing the plug cap adjustment screw (H) over the top and the 5/8" retaining ring (I) over the top of both plug cap pieces. See the zoomed in image below for details of this procedure.
6. Install the bolt (D) through the backrest plate into the strike (G).
7. Repeat steps on opposite side of the backpost.

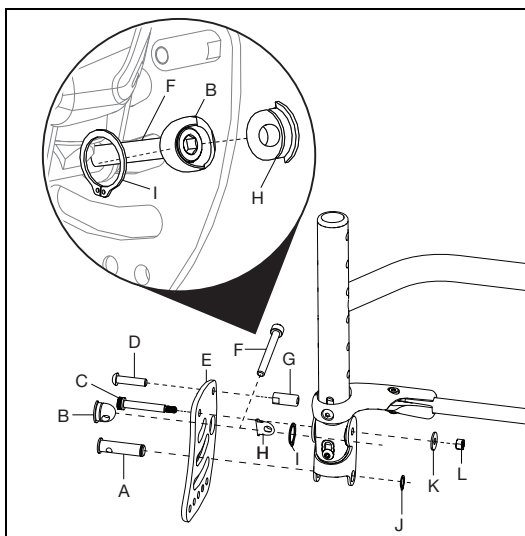

8. Install the backrest assembly onto the chair with the hardware shown below. A 10mm wrench and a 4mm Allen wrench are needed.

NOTE: The holes that the backrest assembly is installed with on the seat frame depend on the desired seat depth desired. Set as needed for desired configuration.

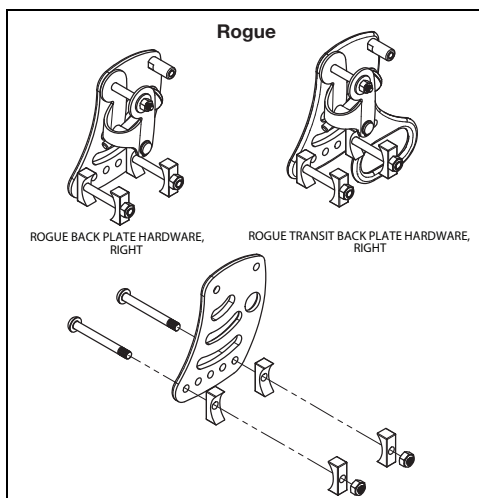

Backrest Assembly - Rogue

Adjusting Backrest Angle

1. The backrest angle can be adjusted by using a 5mm Hex drive, as shown below. Turning the hex drive clockwise decreases the backrest angle and turning it counterclockwise increases the angle. Each angle indicator mark on the back plate is 3° and 3° of angle change takes roughly 2.5 turns.

NOTE: Ensure both sides of the backrest are set in the same position. Use the angle indicator marks as a guide.

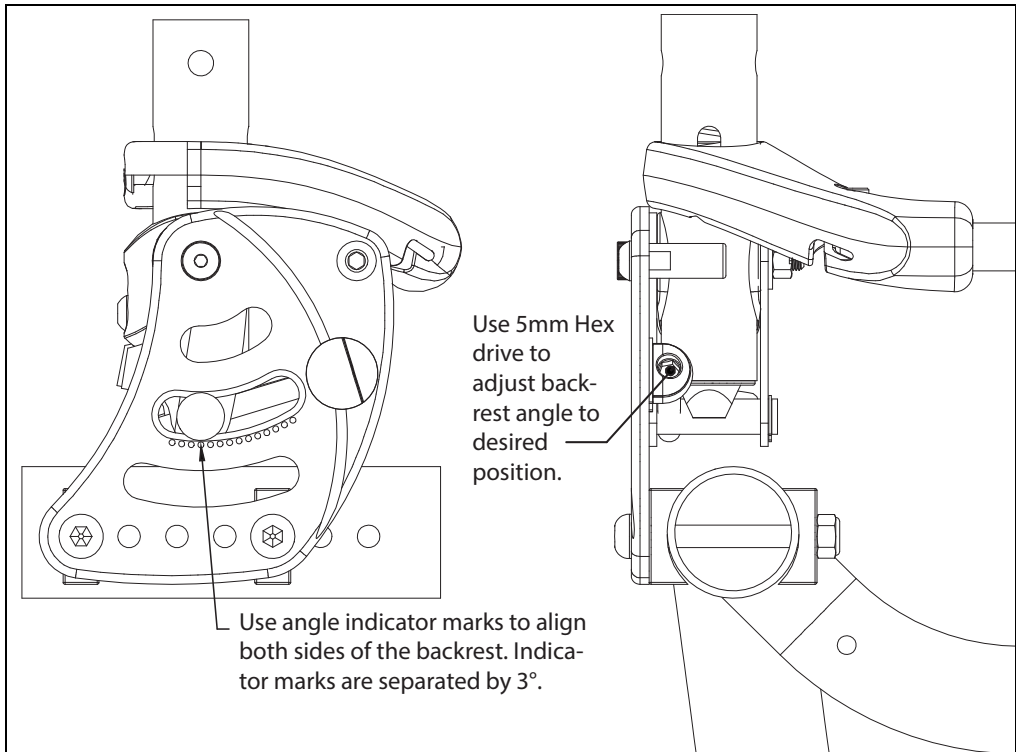

Backrest Assembly - Rogue XP

1. Remove any cushion or seating components that may be in the way of the current backrest removal.
2. Install the back mount (B) onto the chair frame with two bolts (C) and two nuts (A) using a 4mm Allen wrench and a 10mm wrench.

NOTE: The holes used for mounting are determined by the user's desired seat depth and CG.

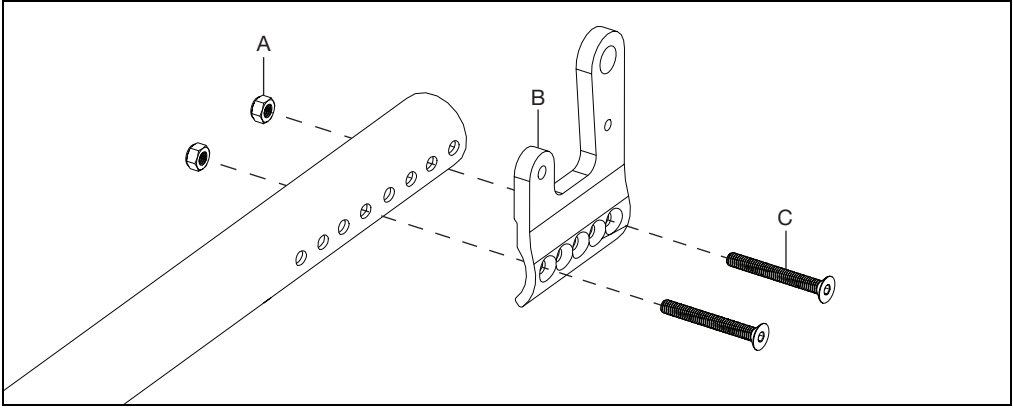

3. Secure the backrest plate (I) to the back mount with bolt (J), nylon washer (G), large nylon washer (H), washer (G) and nut (F) using a 4mm Allen wrench and a 10mm wrench.
4. Install the release cable (A), pin receiver (B), spring (C), lockout pin (D) and spacer into the back mount and the backrest plate (I).

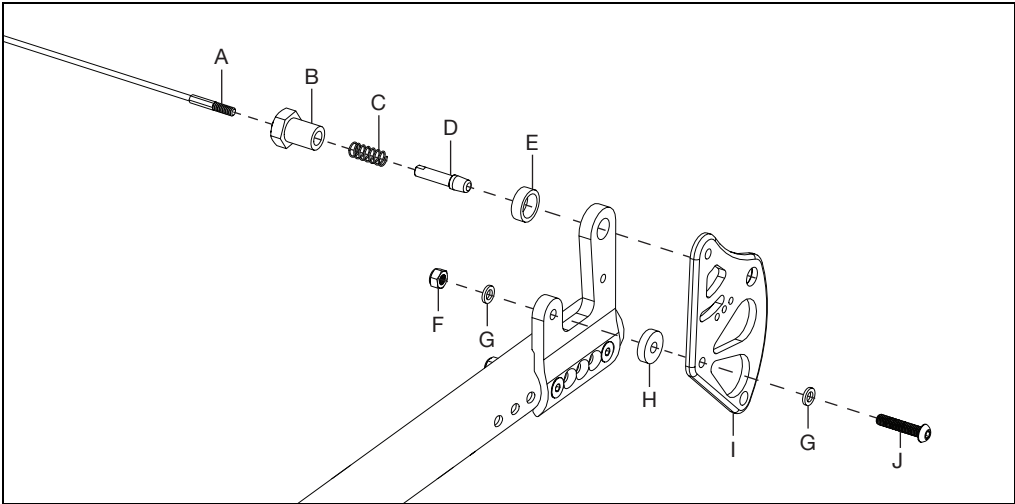

Backrest Assembly - Rogue XP

- Secure backrest plate to back posts with bolt (E), washer (C), saddle (B) and nut (A) using a 4mm Allen wrench and a 10mm wrench.
- Install the arc adjustment cam (C) onto the backrest plate with bolt (I), washer (C), saddle (B) and nut (A) using a 4mm Allen wrench and a 10mm wrench.

NOTE: An offset backrest spacer (D) is used in both sets of hardware that attach to the back post when installing the 1" Offset Backrest Mount.

- Set the angle of the backrest by turning the arc adjustment cam and aligning the cam holes with the backrest plate holes. Once desired angle is achieved, secure by installing the bolt (H) and lock washer (G) using a 3mm Allen wrench.

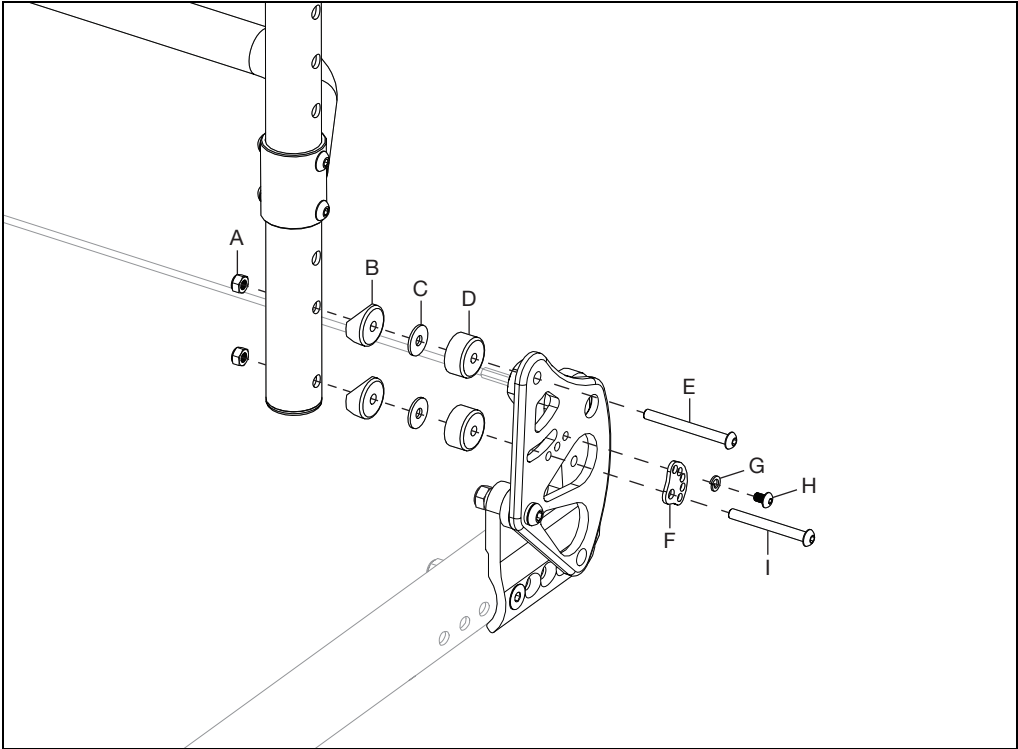

- Repeat steps on opposite side. Ensure the same mounting and angle holes are used so both sides of the backrest match.

Height Adjustable Back Post

1. Install the height adjustable back post (F), plugs (G), sleeve (E), screws (C), threaded barrels (D) and the upper back tube assembly (A) using two 3mm Allen wrenches.

NOTE: The straight upper back, standard push handle and fold down push handle upper backs are shown in the image below.

NOTE: The hole patterns on the lower section of the tubes differ between designs, but the process of installation and adjustment is the same.

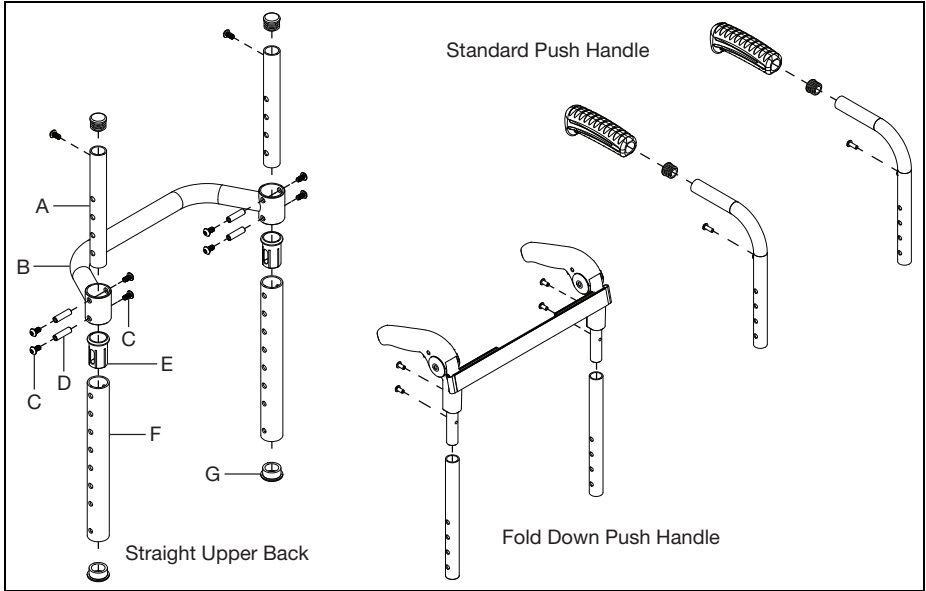

Fixed Height Back Post

1. For the fixed height back post, install the rigidizer bar (D), screws (A & C), threaded barrels (B) and plugs (E) using two 3mm Allen wrenches.

NOTE: The fixed height back post, standard push handle and fold down push handle upper backs are shown in the image below. The standard push handle and fold down push handle upper backs also require sleeves, upper post assemblies and the handle hardware. See image below for details.

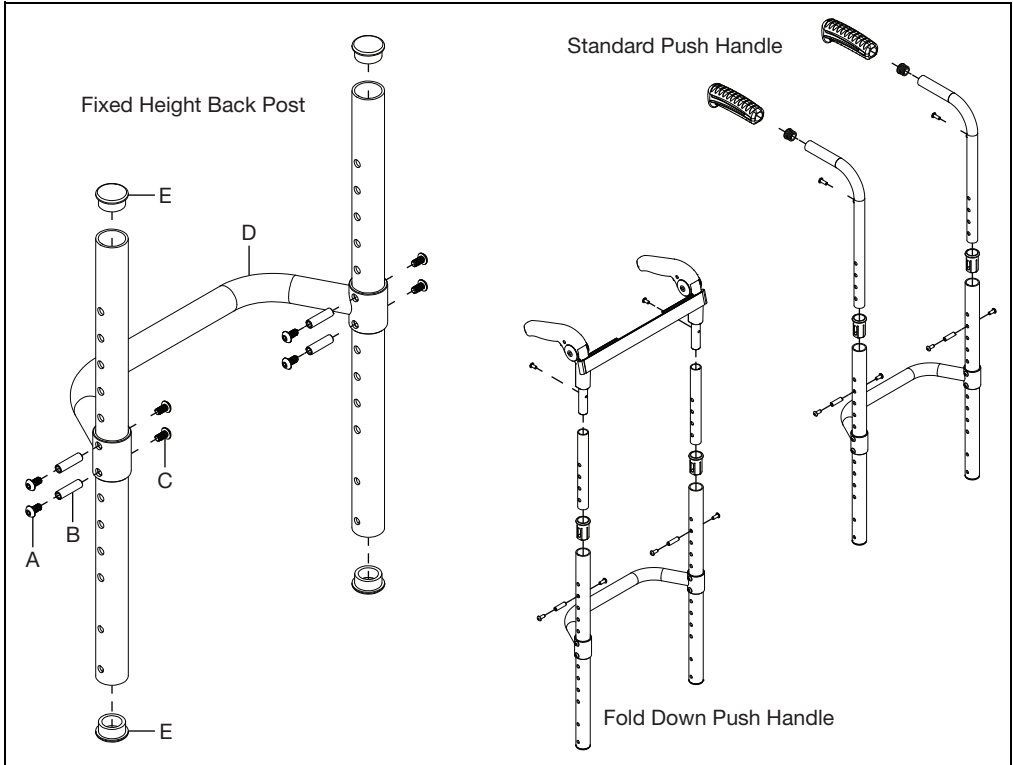

Rigid Stroller Handle

1. Install the stroller handle clamp (E & G) onto the rigidizer bar and secure with two screws (I) and a set screw (H) using a 5mm Allen wrench. The clamps can be installed in the straight mount configuration or the angled mount configuration. See image below.
2. Install the backpost (C), with the handles (A) and plugs (B) installed, into the clamp and secure by installing the clamp handle (D) and nut (F) using a 10mm wrench.

NOTE: The detent button on the bottom of the back post will click into place when properly installed.

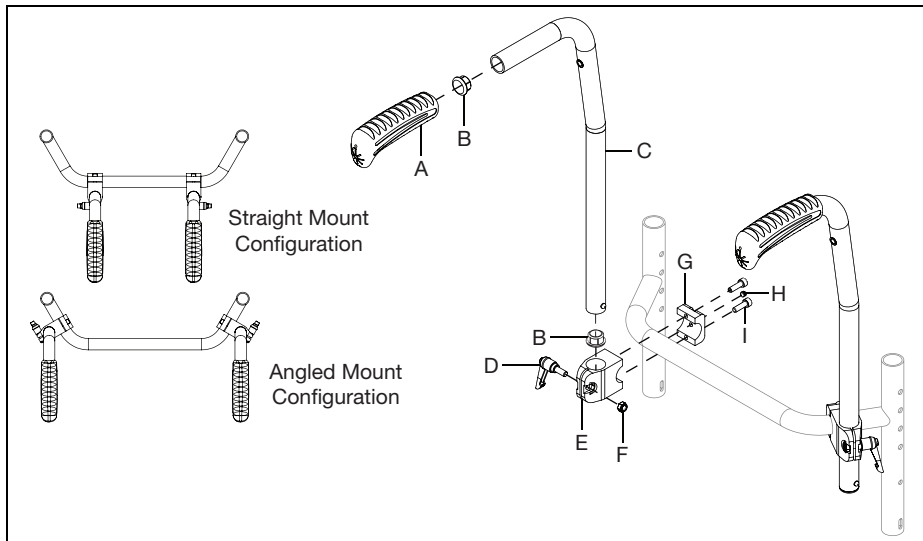

Ergo Stroller Handle - Available on Rogue XP

1. Install the ergo stroller handle clamp (F & H) onto the middle of the rigidizer bar and secure with two screws (I) and a set screw (J) using a 5mm Allen wrench.
2. Install the backpost (C), with the handle (A) and plug (B) installed, into the clamp and secure by installing the clamp handle (E) and nut (G) using a 10mm wrench.

NOTE: The detent button (D) on the bottom of the back post will click into place when properly installed.

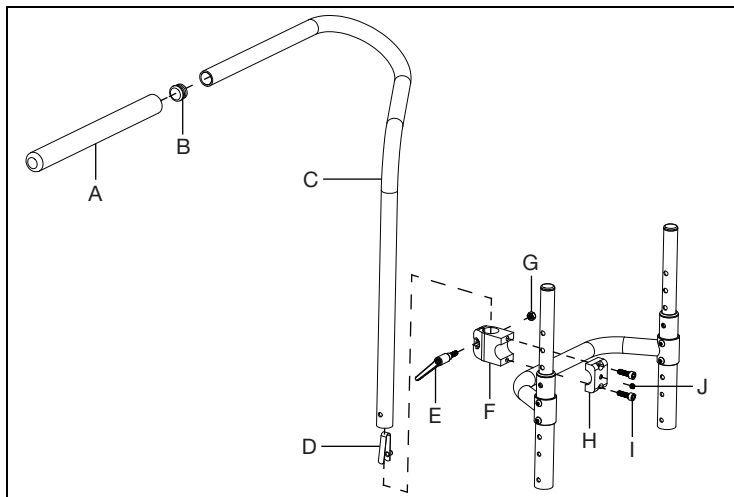

Bolt-On Push Handle

1. Install the clamps (B & C) and bolt-on push handle tube (E) onto the rigidizer bar and secure with two screws (A) and two nuts (D) using a 5mm Allen wrench.

NOTE: The clamps can be installed onto the rigidizer bar in the straight or angled orientation. See image below for details.

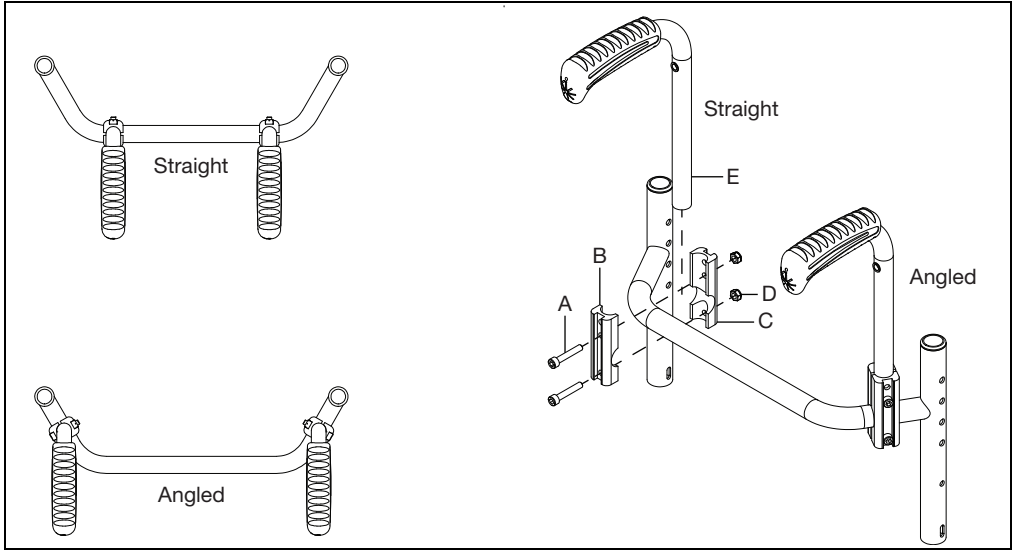

2. Repeat installation step with the second bolt-on push handle.

Height Adjustable T-Arm

1. Install the T-Arm receiver (B) and the T-Arm bracket (C) onto frame with two bolts (D) and two nuts (A) using a 5mm Allen wrench and a 10mm wrench.

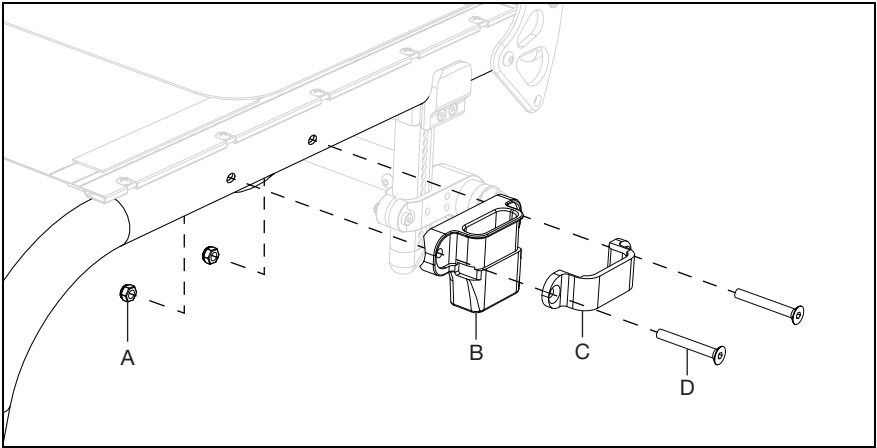

2. Install the T-Arm assembly into the receiver. Ensure the latch (B) "clicks" into place. Adjust the height by loosening the height lever (A) and sliding the T-Arm post up or down. Repeat steps on opposite side.

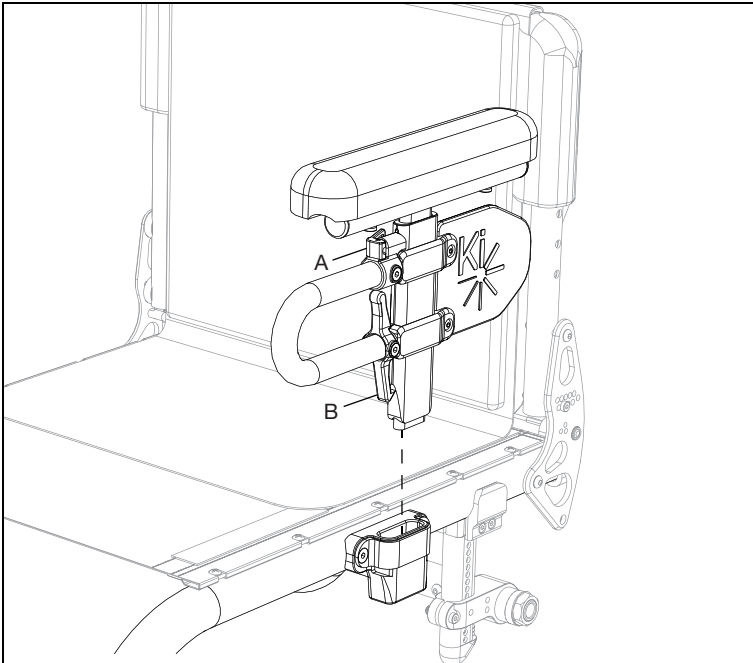

Angle Adj. Locking Flip Up Extendable Armrest - Available on Rogue XP

1. Set the angle of the armrest. Tighten the bolt once angle is set.

NOTE: There are 7 angle adjustments in 5° increments from -5° to 25°.

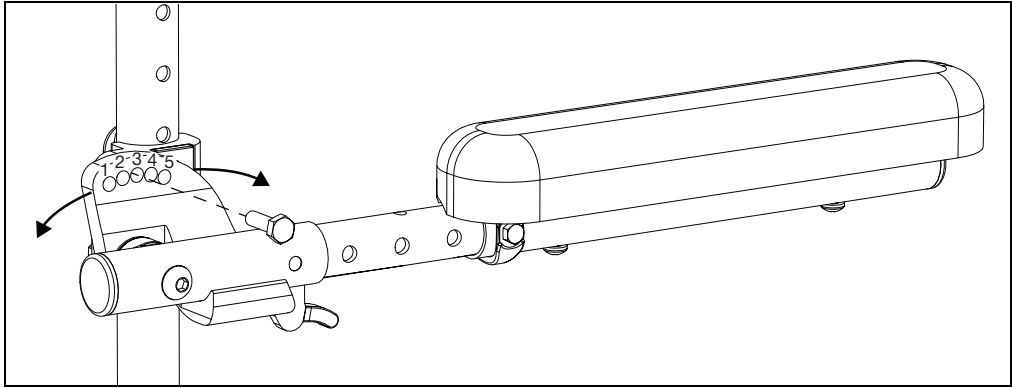

2. Set the length of the armrest. To adjust the length, remove the bolts and spacer on the tube and the screw closest to the back of the chair. Slide the armrest to desired length available by the predrilled holes and reinstall the screw and bolts.

NOTE: The armrest can extend up to 4" in 1" increments.

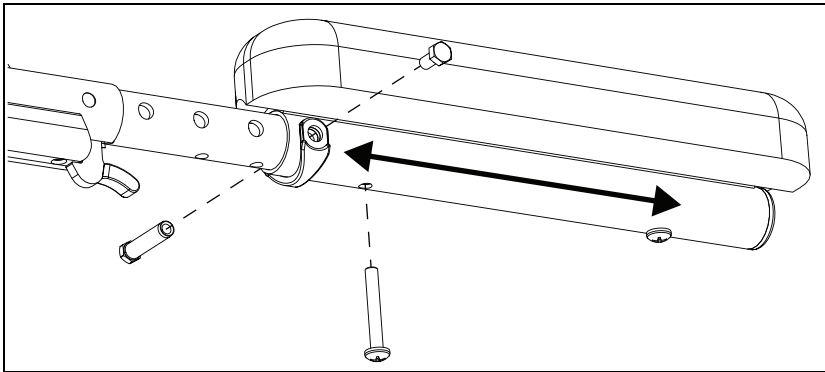

3. Set the height of the armrest. There are four holes on the armrest that allow for two different height settings for each set of holes on the back tube. Use the holes that provide the correct height setting for the user. The two bolts pass through the spacer, sleeves, back posts and into the armrest.

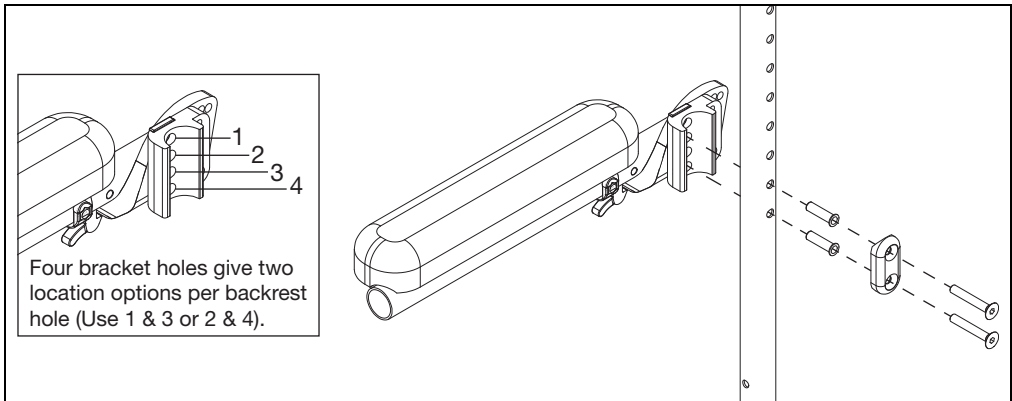

Swing Away Armrest - Available on Rogue

1. Install the swing away arm mount (C) onto the end of the frame tube with two bolts (D), bushing (B) and two nuts (A) using a 4mm Allen wrench and a 10mm wrench. Repeat on opposite side.

NOTE: Depending on the configuration, the backrest hardware may need to be removed to install the arm mount. Reinstall with the same hardware once the arm mount is in place.

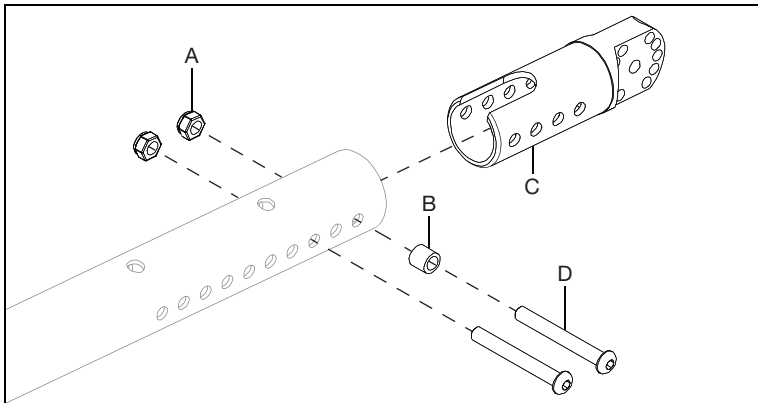

2. Install the swing away receiver (F) onto the swing away arm mount with three bolts (G & H) and three nuts (D & E) using a 3mm Allen wrench, a 4mm Allen wrench, an 8mm wrench and a 10mm wrench. Repeat on opposite side.
3. Finish installation by installing the two bolts (A) and the threaded barrel (C) using two 5mm Allen wrenches. The hole that the two bolts and the threaded barrel are installed in determine the armrest height. Finish by dropping the armrest into the receiver. Repeat on opposite side.

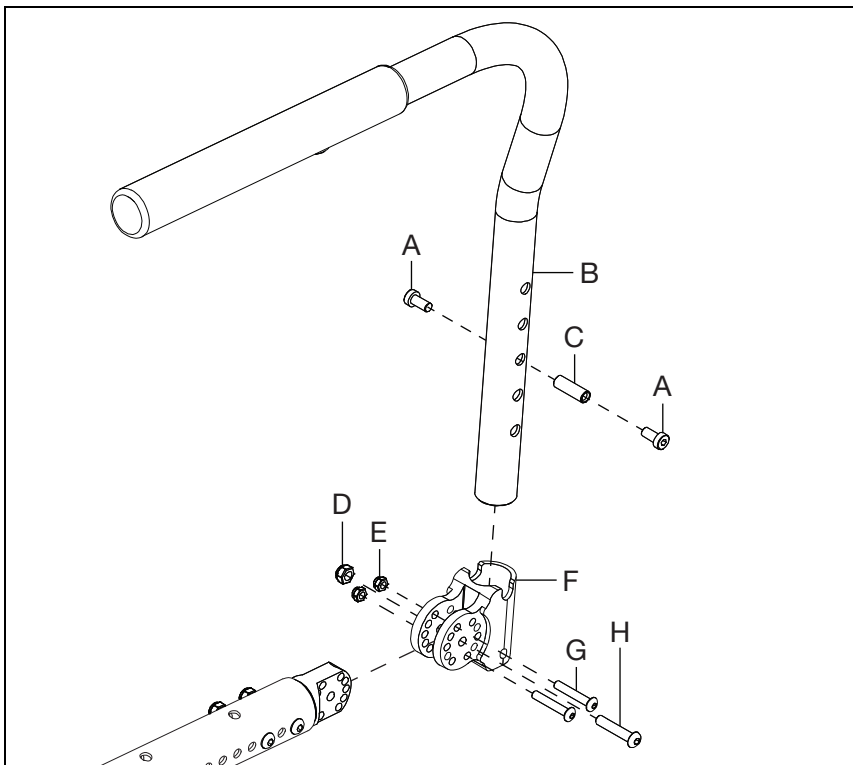

Swing Away Armrest - Available on Rogue XP

1. Detach the backrest from the backrest plate and install the swing away receiver (A) between the backrest and backrest plate along with arc adjustment cam (D) with two screws (C & F) and two lock washers (B & E) using a 3mm Allen wrench and a 4mm Allen wrench. See image below.

NOTE: The backrest cable will also need to be detached, put through the swing away receiver hole and back into backrest plate.

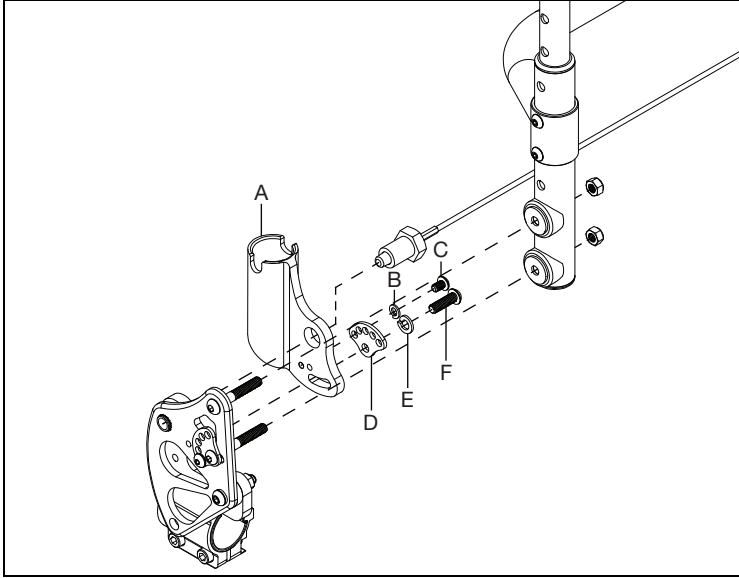

2. Install two bolts (A) and the threaded barrel (B) into the swing away armrest (C). The bolts act as stops when the armrest is dropped into the receiver, controlling the armrest height. Change height setting as needed and repeat steps on opposite side.

NOTE: There is a short and tall swing away arm available. The short has a height range of 7" - 9" and the tall has a height range of 9.25" - 11.25".

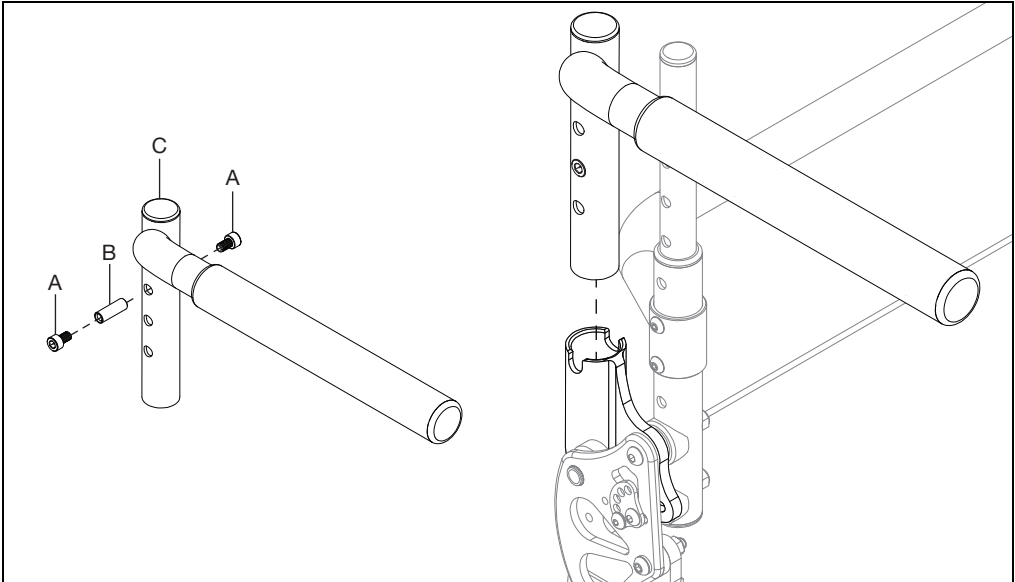

Cane and Crutch Holder

1. Install crutch holder cup (I) onto the crutch holder tube (F) with two screws (J), two washers (H) and two nuts (G) using a 3mm Allen wrench and an 8mm wrench.
2. Install the crutch holder tube assembly onto the camber tube with the clamps (D & E) and two bolts (C) using a 5mm Allen wrench.
3. Install the crutch holder velcro strap (A) onto the back post (ensure the crutch holder cup and velcro strap are on the same side of chair) with a screw (B) using a 3mm Allen wrench.

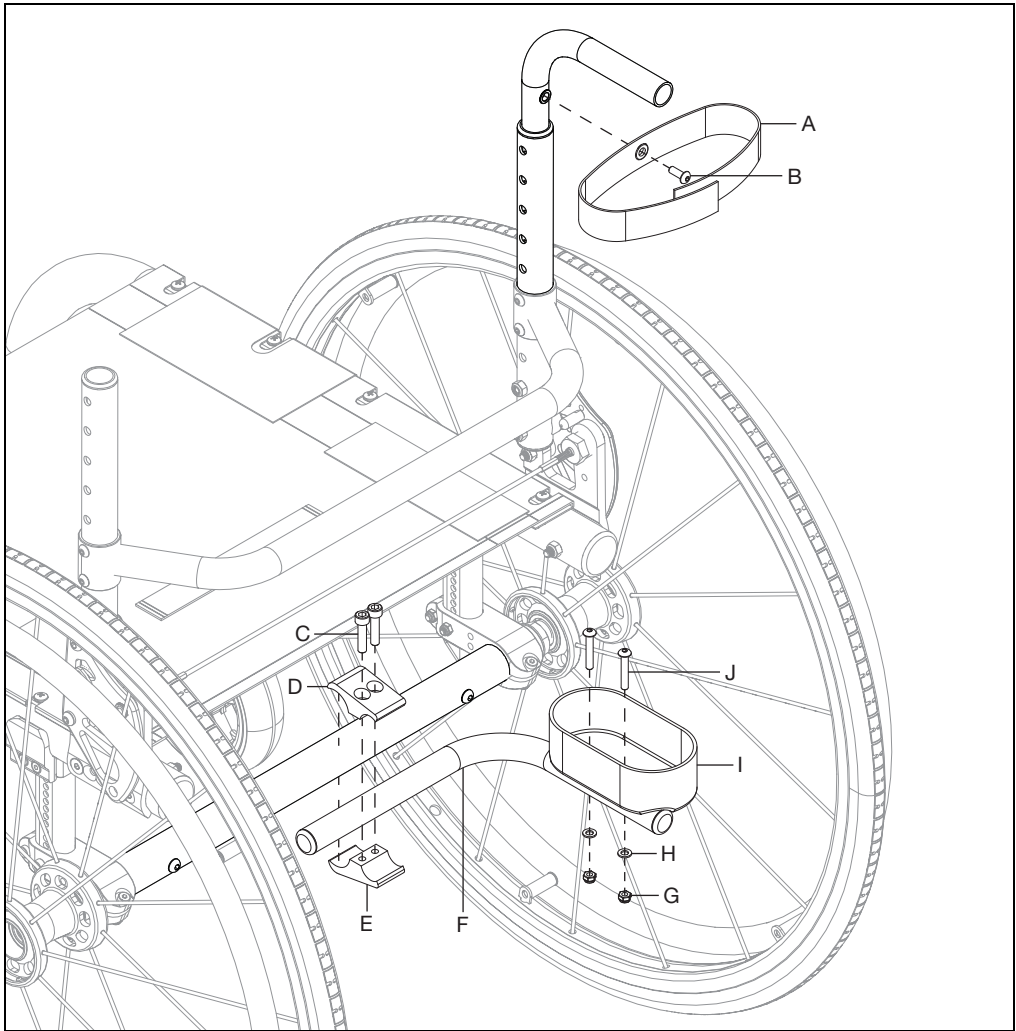

Luggage Carrier

NOTE: There are different sizes of clamps to fit all types of chairs and configurations. The carrier can be mounted to the frame or footrest tube on Rigid chairs. The installation is the same whether it is being installed on the frame or footrest tubes.

1. Install luggage carrier fork (B) and clamp (E) by installing two screws (A) and barrel nut (C) through the clamp and fork using two 4mm Allen wrenches.
2. Secure the clamp in the desired location by installing and tightening the screw (F) and nut (D) on the backside of the clamp using a 5mm Allen wrench.

NOTE: The nut for the backside screw goes into a recess in the clamp. Ensure that nut stays in place.

3. Repeat on opposite side.

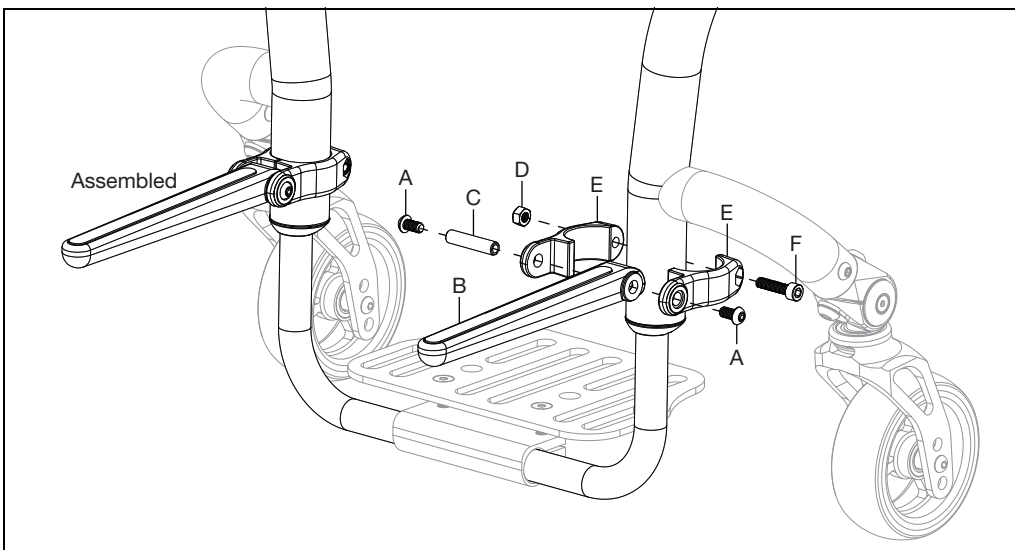

Using the Luggage Carrier

1. Operating position for the luggage carrier is when the forks are folded down (See image below). The max weight capacity is 55lbs.
2. When not in use, fold the luggage carrier up.

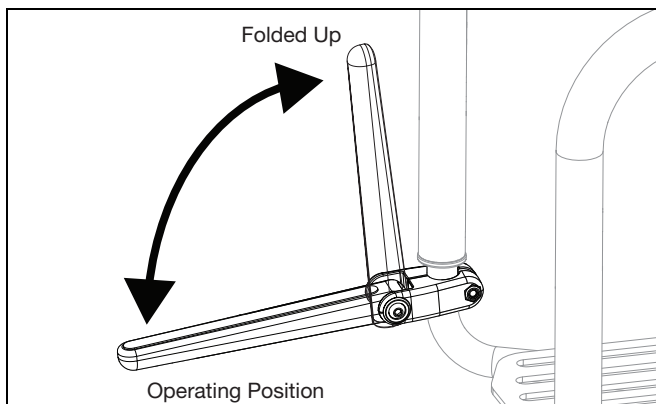

Handrim Configurations

NOTE: Not all wheels listed below are available for specific models. See an order form or the online parts manual for more information on your specific chair model.

Handrim Hardware Chart															
Wheel		Handrim Connection					Handrim								
Wheel	Wheel Part No.	Connection Points	Rivet/Tab	Spacer*	Screw*	Aluminum Anodized	Superlight	Plastic Coated	Projection	Ergonomic Standard	Ergonomic LT	Natural Fit Standard	Natural Fit LT	Flex Rim	
22" Spoke	16730	5 or 6	16732 (Used with 5 Rivet) 100698 (Used with 6 Rivet)	100653 (Not used w/ Superlight Handrim)	Aluminum, Plastic Cld. Projection, Ergonomic: 100654 Natural Fit: 100835 Superlight: Screw: 100669 Nut: 100657	10898 (5 Rivet)		10964 (5 Rivet)	12824 (6 Rivet)	13082 (6 Rivet)	13085 (6 Rivet)	200538 (6 Rivet)	200201 (6 Rivet)		
24" Spoke	16728	5 or 6	Not used w/ Superlight Handrims			100975 (5 Rivet)	10161 (6 Tab)	100976 (5 Rivet)	12825 (6 Rivet)	13083 (6 Rivet)	13086 (6 Rivet)	100793 (6 Rivet)	200202 (6 Rivet)		
18" MAXX Spoke	109285	3				100206									
20" MAXX Spoke	108244	6	100698 (Not used w/ Superlight Handrim)	100653 (Not used w/ Superlight Handrim)	Aluminum, Plastic Cld. Projection, Ergonomic: 100654 Natural Fit: 100835 Superlight: Screw: 100669 Nut: 100657	200536		12828							
22" MAXX Spoke	10505					100560		12820	12824	13082	13085	200538	200201		
24" MAXX Spoke	10506					200349	10161	12821	12825	13083	13086	100793	200202		
25" MAXX Spoke	107436					200350		12822	200548	13084	13087	200539	200540		
26" MAXX Spoke	107437					200351		12823	200549				100907	10454	
20" MAXX Mag	11853	6		Aluminum, Plastic Coated, Projection: 100629	Aluminum, Plastic Coated, Projection, Ergonomic: 103549 Natural Fit & Ergonomic: 10756	200536		12828							
22" MAXX Mag	11854					100560		12820	12824	13082	13085	200538	200201		
24" MAXX Mag	11855					10507	12821	12825	13083	13086	100793	200202			
24" Superlight	10169	6			Screw: 100536	100754	10161	100836		13080	13081	100830	100828		
25" Superlight	10160						10160	10161					10464	10460	
20" Spinery Spox	See Spinery Spox Page	6			Screw: 100669 Nut: 100657	10325		10379							
22" Spinery Spox						100827		100808			100889	100888			
24" Spinery Spox						100766	10161	10065			100830	100828			
25" Spinery Spox						100767	10160	100765			10464	10460			
26" Spinery Spox						10477	10148				200200	100950			
22" Spinery LX	See Spinery LX Page	6			Screw: 100669 Nut: 100657	100827		100808				100889	100888		
24" Spinery LX						100766	10161	10065			13080	13081	100830	100828	See Spinery LX Page
25" Spinery LX						100767	10160	100765			10464	10460			
26" Spinery LX						10477	10148				200200	100950			

* Spacer and screw part numbers listed in the chart are for standard handrim mounting. If using close mount handrim mounting on aluminum anodized, plastic coated or projection handrims, use part number

100792 for the spacer, part number 10266 for the screw on Ki Spoke and MAXX Spoke wheels, part number 100666 for the screw on 5-Spoke X Core wheels, or part number 100654 for the screw on MAXX Mag wheels.

Handrim Hardware Chart (Discontinued Wheels)														
Wheel		Handrim Connection					Handrim							
Wheel	Wheel Part No.	Connection Points	Rivet/Tab	Spacer*	Screw*	Aluminum Anodized	Superlight	Plastic Coated	Projection	Natural Fit Standard	Natural Fit LT	Flex Rim		
18" Ki Spoke	200529	3				100206		10106						
20" Ki Spoke	200530	6	100698	100653	Aluminum, Plastic Cld. Projection: 100654 Natural Fit: 100835	200536		200542						
22" Ki Spoke	200531					100560	100576	100569	200538	200201				
24" Ki Spoke	200532					200349	100577	200547	100793	200202				
25" Ki Spoke	200533					200350	10070	200548	200539	200540				
26" Ki Spoke	200534					200351	100578	200549	100907	10454				
20" 5-Spoke X Core	10961	5		Aluminum, Projection, Natural Fit: 100629	100724	10897		10963						
22" 5-Spoke X Core	10962					10898		10964						
24" 5-Spoke X Core	10960					100975		100976	200546					
24" 5-Spoke X Core	10960							Plastic Cld: 10756	10893				100768	100769

* Spacer and screw part numbers listed in the chart are for standard handrim mounting. If using close mount handrim mounting on aluminum anodized, plastic coated or projection handrims, use part number

100792 for the spacer, part number 10266 for the screw on Ki Spoke and MAXX Spoke wheels, part number 100666 for the screw on 5-Spoke X Core wheels, or part number 100654 for the screw on MAXX Mag wheels.

Handrim Construction

The sequencing of hardware for the three styles of handrims is shown below. The specific hardware used is determined in the chart on the previous page, based on the tire and handrim being used.

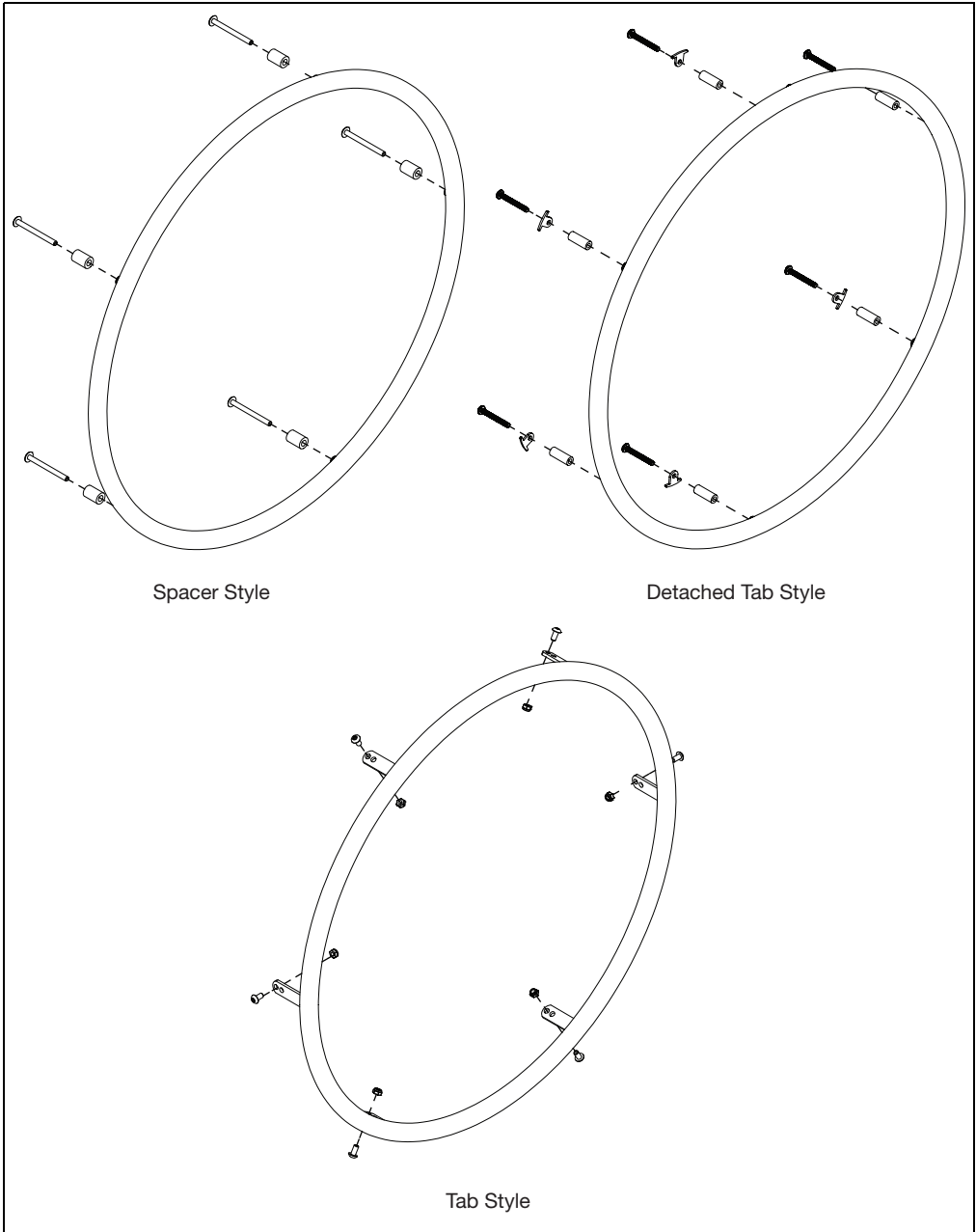

Seat Pan

NOTE: Remove any current seating or cushions before installing the seat pan.

3. Install the seat pan (B) onto the chair frame and secure with screws (A) using a Phillips screwdriver.
4. If not already done, install the tape onto the seat as shown in the image below. The tape should cover as much area as possible without hanging over the edge or covering one of the screw holes.

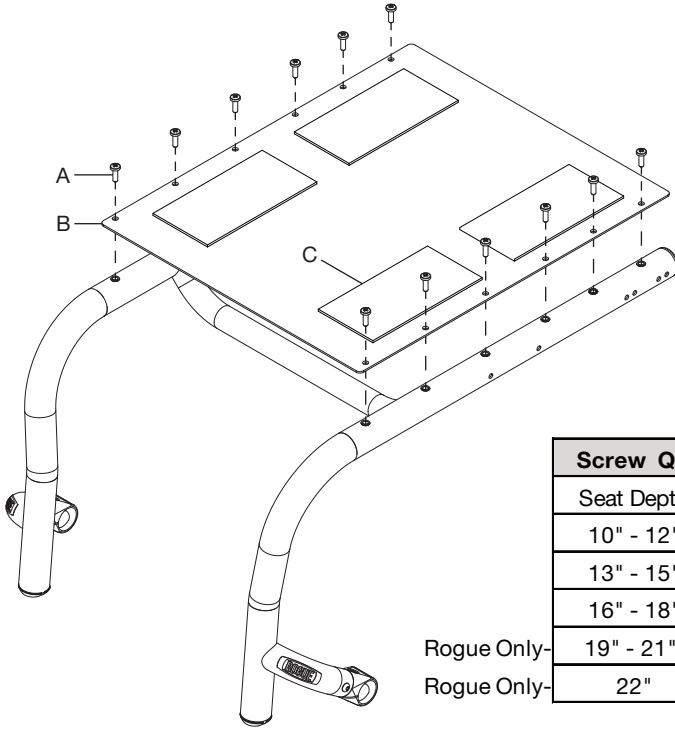

Screw Qty Per Chair	
Seat Depth	Screw Qty
10" - 12"	6
13" - 15"	8
16" - 18"	10
Rogue Only- 19" - 21"	12
Rogue Only- 22"	14

Part Number	Tape Size	Seat Pan Depth
004458	3" X 4"	10" - 11"
004458 & 004459	3" X 4" & 3" X 5"	12"
004459	3" X 5"	13"
004460	3" X 6"	14" - 22" (19" - 22" Rogue Only)

Seat Upholstery

1. Install the seat rail (B) into the sleeve on the edge of the seat upholstery (C). Repeat on opposite side. The seat rail is shown outside of the sleeve to show the hole alignment in the image below.
2. Secure the seat rail and seat upholstery onto the chair frame with screws (A) using a Phillips screwdriver.

Rogue XP

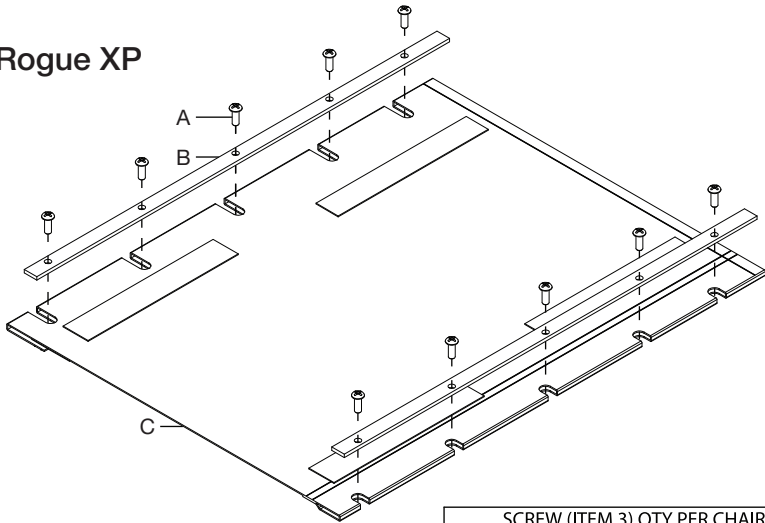

SCREW (ITEM 3) QTY PER CHAIR	
SEAT DEPTH	SCREW QTY
10" - 12"	6
13" - 15"	8
16" - 18"	10
19" - 20"	12

Rogue

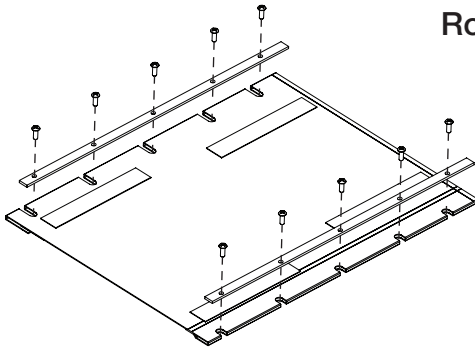

Seat sling used on 10" - 13" wide

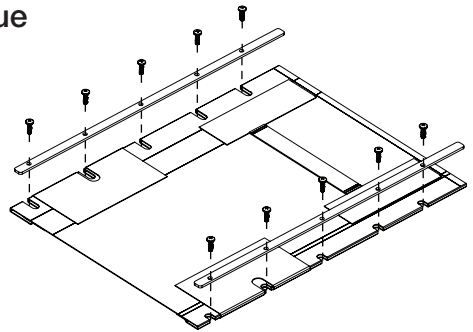

Seat sling used on 14" - 22" wide

SCREW (ITEM 3) QTY PER CHAIR	
SEAT DEPTH	SCREW QTY
10" - 12"	6
13" - 15"	8
16" - 18"	10
19" - 21"	12
22"	14

Side Guards

Side Guard Receiver

1. There are three types of side guard receivers that may be used. The mounted side guard receiver (B) is installed onto the frame with screw (A), washer (C) and nut (D) using a 4mm Allen wrench and a 10mm wrench. The clamp side guard receivers (G & H) are installed onto the frame with two screws (E) and two washers (F) using a 5mm Allen wrench. The anti-rattle side guard receiver (I) is installed the same as the clamp side guard receiver, it just has two additional rubber buttons (J) installed into the receiver. Repeat on opposite side.

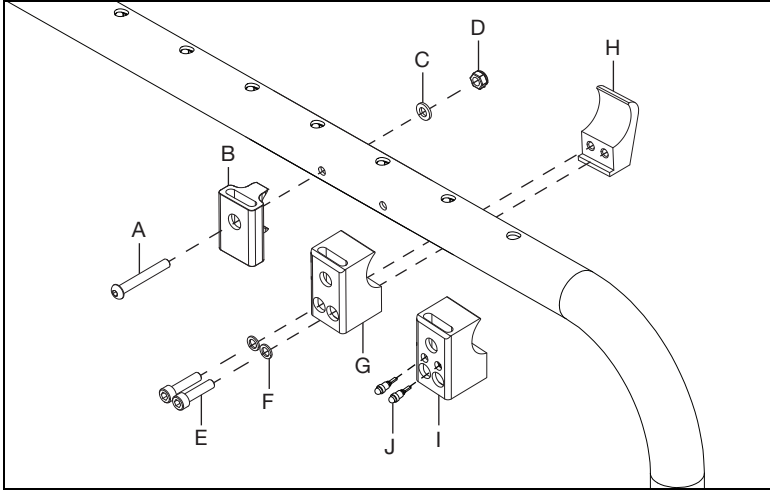

Removable Adult Side Guard

1. Install the adult side guard (D) onto the side guard post (C) with two screws (A) using a 4mm Allen wrench. On the opposite side, install the side guard post stop (B) with a screw (A) using a 4mm Allen wrench.

NOTE: There are two sets of holes that the side guard post (C) can be installed onto the side guard with. Choose the holes that place the side guard in the desired position. The height is also adjusted with the hole that the side guard post stop (B) is installed in.

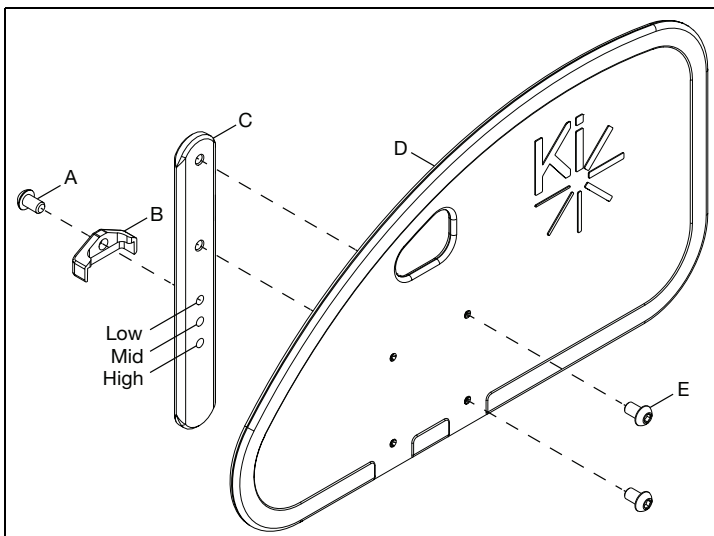

Side Guards

2. Install the side guard assembly into the receiver so the side guard post stop faces the outside of the chair.

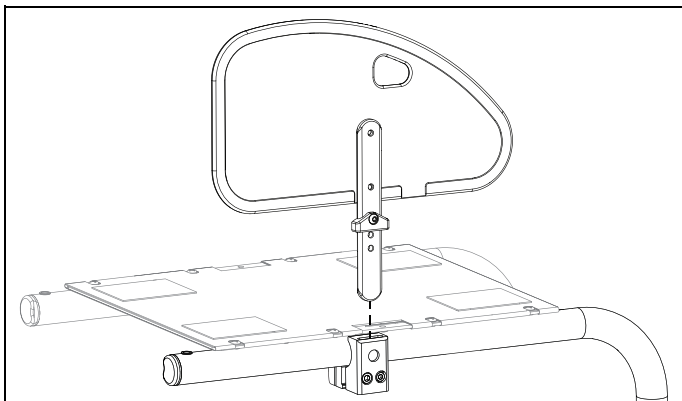

Removable Pediatric Side Guard

1. Install the pediatric side guard (D) onto the side guard post (C) with two screws (A) using a 4mm Allen wrench. On the opposite side, install the side guard post stop (B) with a screw (A) using a 4mm Allen wrench.

NOTE: The height of the pediatric side guard can be adjusted with the three holes on the side guard post (C).

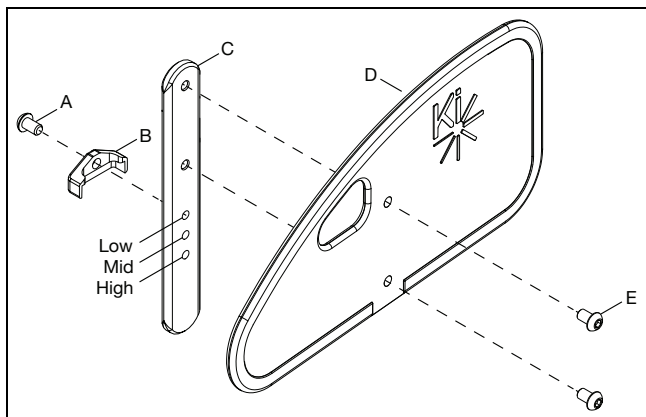

2. Install the side guard assembly into the receiver so the side guard post stop faces the outside of the chair.

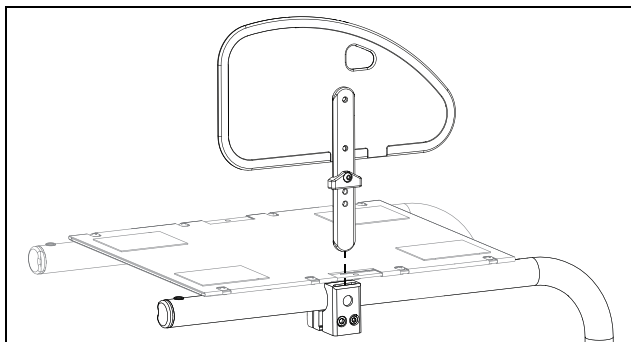

Side Guards

Adjustable Fender Side Guard

1. Install post (B), post mount plate (A) and bolts (D) onto the fender (C) using a 3mm Allen wrench.

NOTE: There are three mounting positions that can be used. Pick the holes that put the fender in the desired position for the occupant. This can be adjusted again later.

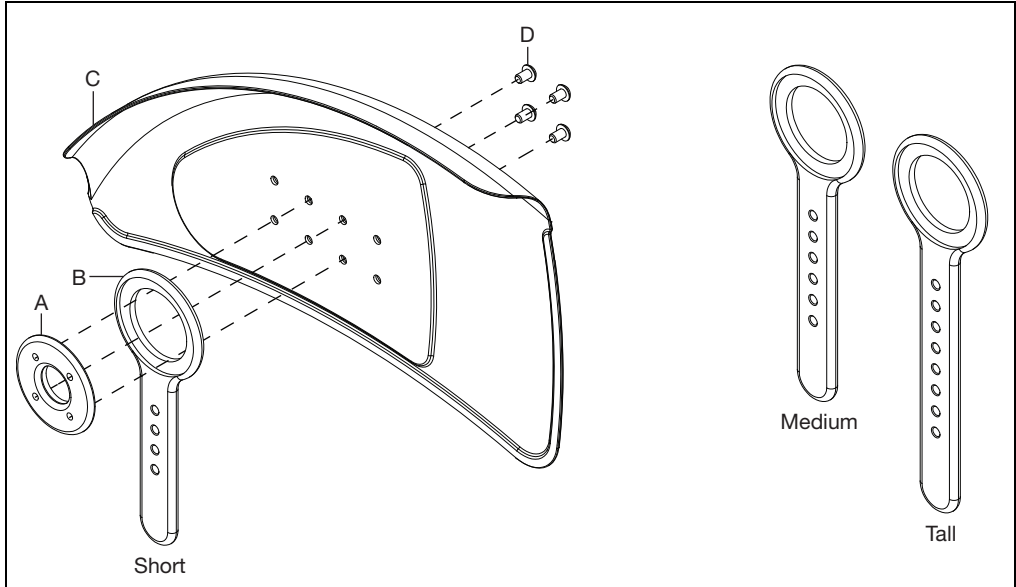

2. Set the height of the back post by installing the post stop (B) with a screw (A) using a 4mm Allen wrench. The height of the post can also be adjusted later if needed.

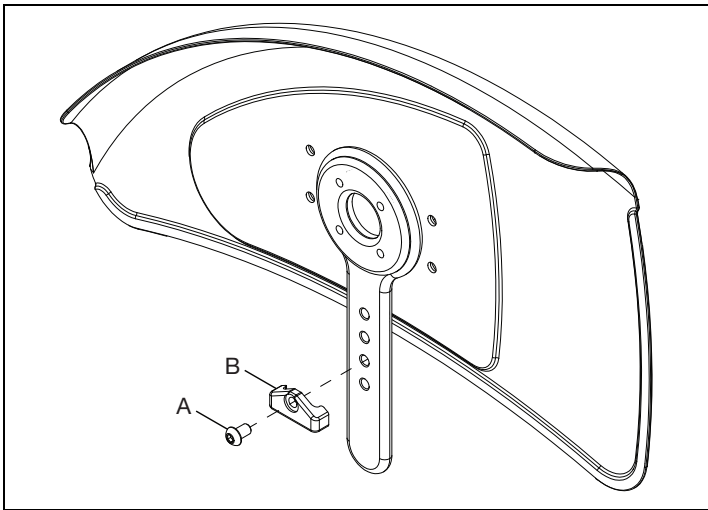

3. Install the fender assembly into the receiver by dropping the post into the receiver slot. Adjust the fender if needed.
4. Repeat steps on opposite side.

Side Guards

Angle Adjustments

The angle of the fender can also be changed to align the fender with the profile of the tire if needed.

1. Remove the four bolts from the post mount with a 3mm Allen wrench.
2. Rotate the fender, either way, to align the fender with the profile of the tire.
3. Rotate the post mount plate so the four holes align with the desired holes on the fender.
4. Reinstall the the four bolts securing the fender to the post and post mount plate using a 3mm Allen wrench.

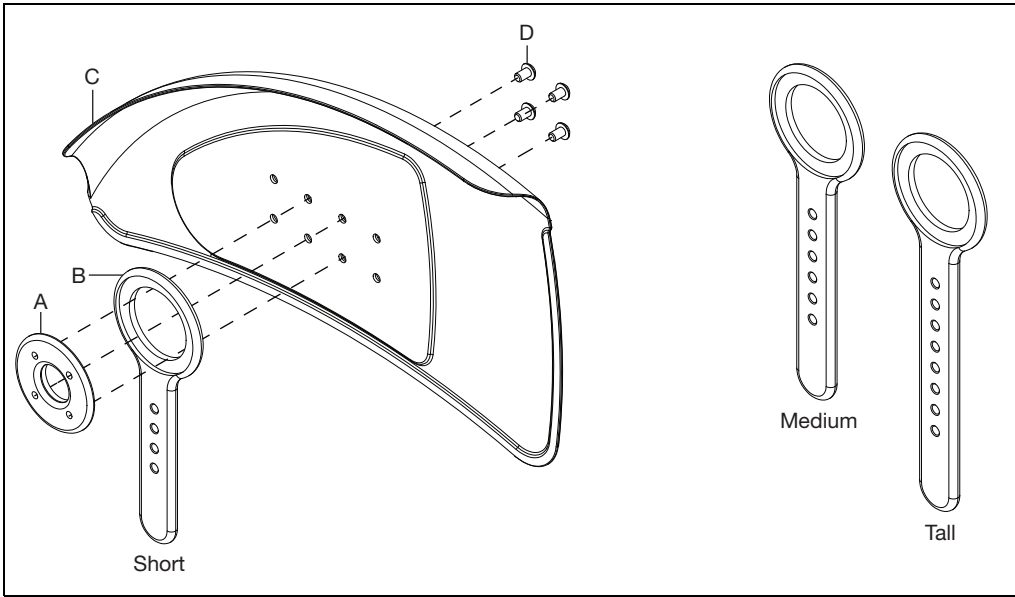

Transit

NOTE: The new backrest assembly, standard and transit, uses new backrest tubes. If the chair does not already have the new backrest design, new backrest tubes are needed as the old tubes are not compatible.

1. Remove any cushion or seating components that may be in the way of the current backrest removal. Also, remove any backrest tubes and/or handles that may be used after the backrest installation process.

NOTE: Refer to parts manual for additional information on compatibility restrictions for the new backrest design.

2. There are two types of backrests. Use the image below to determine the version you have. For an original backrest, remove three bolts (E, F & I), three saddles (C & J), four washers (B, H & L) and three nuts (A, K & M) from back plate (D) to remove the back post using a 4mm Allen wrench, an 8mm wrench and a 10mm wrench. Twist off the cable housing to detach cable from back plate. Repeat on opposite side. For a new backrest, remove three bolts (E & F), one washer (B), four saddles (C & H), one saddle back (G) and three nuts (A & I) using a 4mm Allen wrench, a 5mm Allen wrench, an 8mm wrench and a 10mm wrench. Remove the screw (D) from the backrest release bar using a Phillips screwdriver and repeat on opposite side.

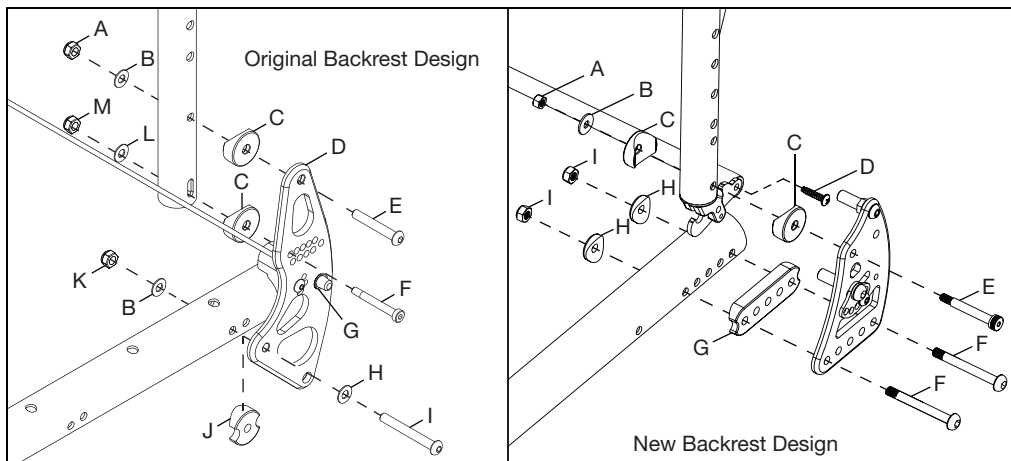

3. Install new backrest by installing pivot (F) into new backrest tubes and securing with bolt (E), back plate (D), two saddles (C), washer (B) and nut (A) using a 5mm Allen wrench and an 8mm wrench. Repeat on opposite side.

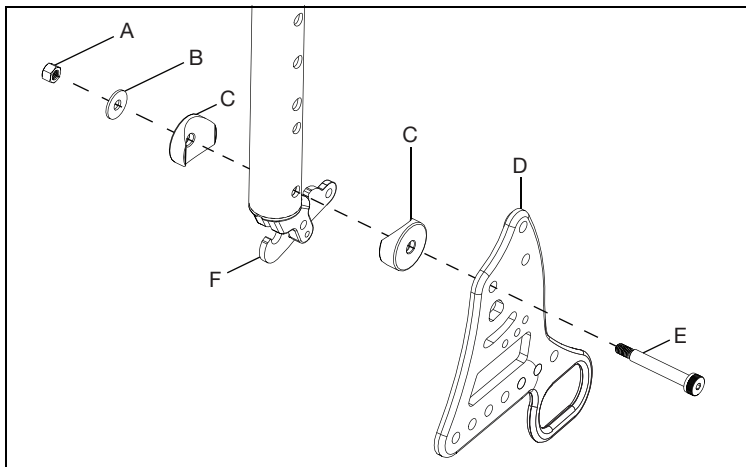

Transit

4. Install bolt (G), lock washer (F) and strike hex (D) using a 4mm Allen wrench and a 10mm wrench.
5. Install backrest release bar (N) and secure with screw (C) using a Phillips screwdriver. Repeat on opposite side.
6. Install two bolts (J & K), two lock washers (F & I), arc adjustment cam (H), washer (E) and strike hex (D) using a 3mm and 4mm Allen wrench along with a 10mm wrench.

NOTE: The angle of the backrest can be adjusted using the different arc adjustment cam holes. Choose the configuration that works best for the chair user.

7. Secure backrest assembly to the frame by installing two bolts (L), saddleback (M), two saddles (B) and two nuts (A) using a 4mm Allen wrench and a 10mm wrench.

NOTE: The two bolts (L) determine the seat depth based on the frame holes that are used. Choose the configuration that works best for the chair user.

NOTE: Longer fasteners have been provided to accommodate a setup where the backrest and CG are set in the same spot.

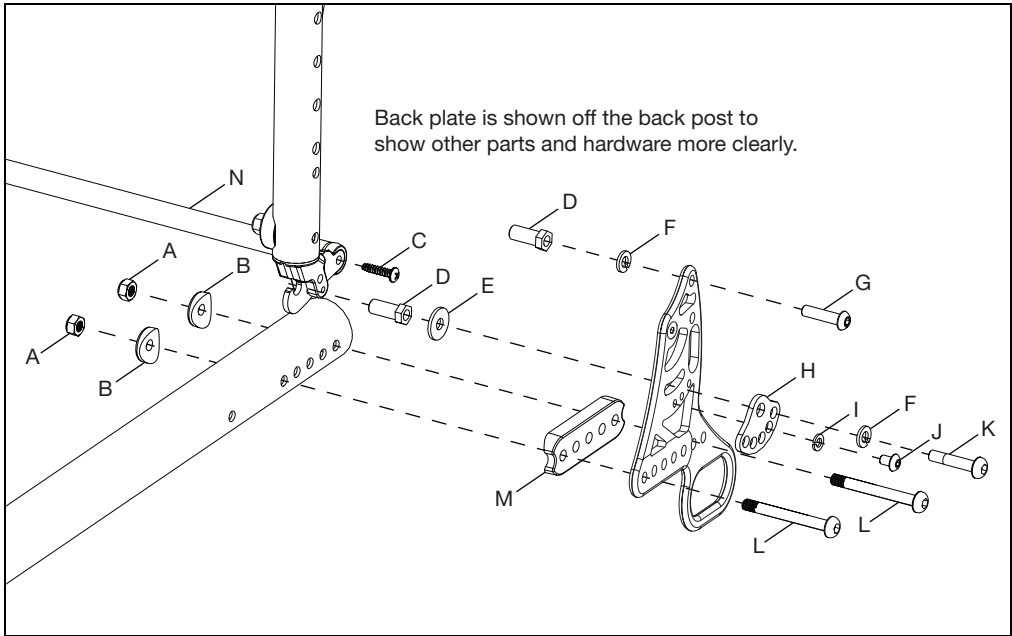

Angle Adjustable Footrest

1. Install the footrest extension tubes (A) into the footrest adjustable clamp (G).
2. Install the footplate (E) onto the clamp and secure with two screws (D) and two nuts (H) using a 5mm Allen wrench and a 10mm wrench. If a riser (F) is being used to elevate the footrest platform, install between the footrest platform and the footrest adjustable clamp.
3. Install the footrest protectors (C) by peeling the backing off of the tape (B) and sticking the tape inside the footrest protector. Peel the remaining backing off of the tape and snap footrest protectors onto the footrest as seen below.

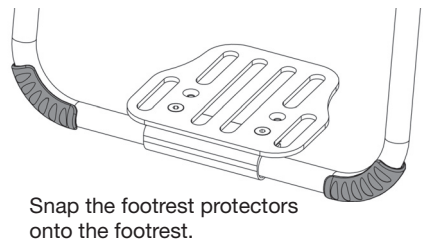
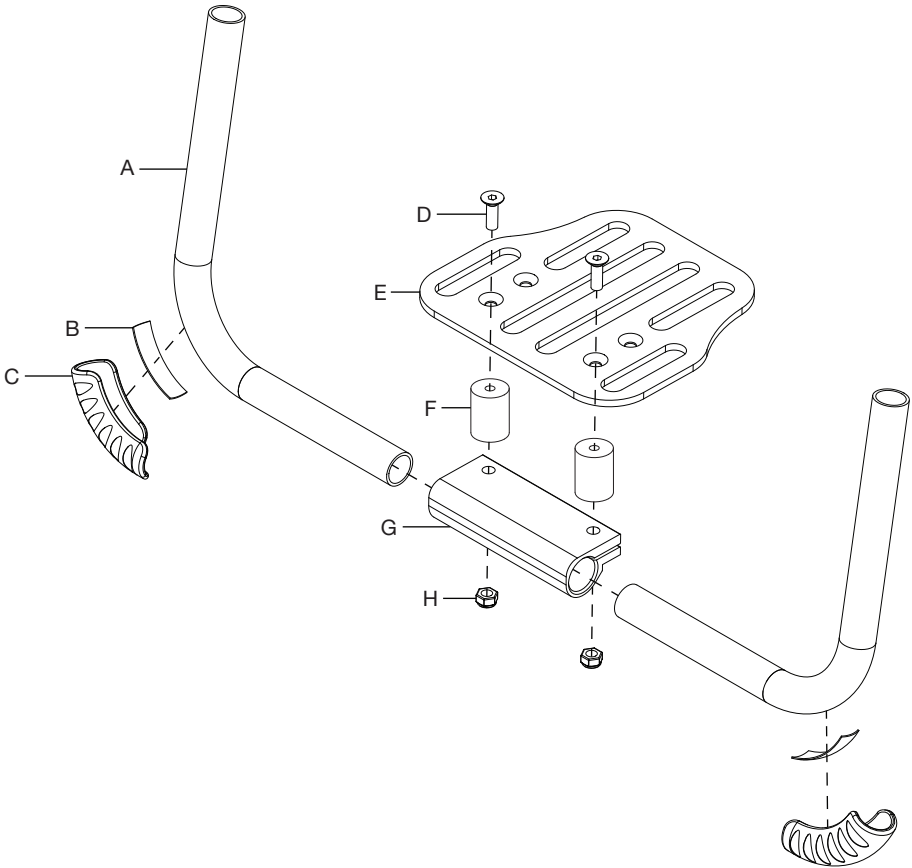

Angle Adjustable Flip Under Footrest

1. Install the footrest tubes (A & D) through the pivots (B) into the footrest flip stop clamp (C).

NOTE: The footrest tube and the footrest tube offset are shown below. The installation process is the same for both footrest tubes.

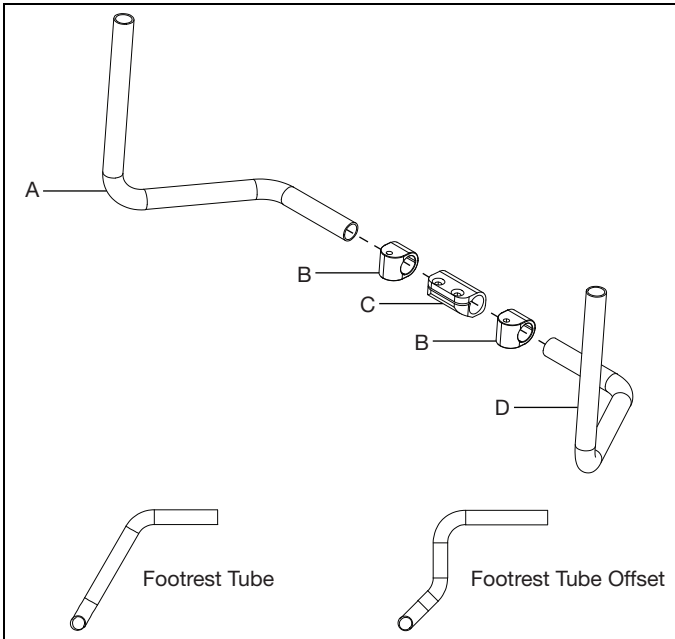

2. Install two screws (C) into the footrest flip stop clamp to secure the footrest tubes using a 5mm Allen wrench. Install the footrest platform (B) onto the footrest flip stop clamp with two screws (A) and two nuts (D) using a 5mm Allen wrench.

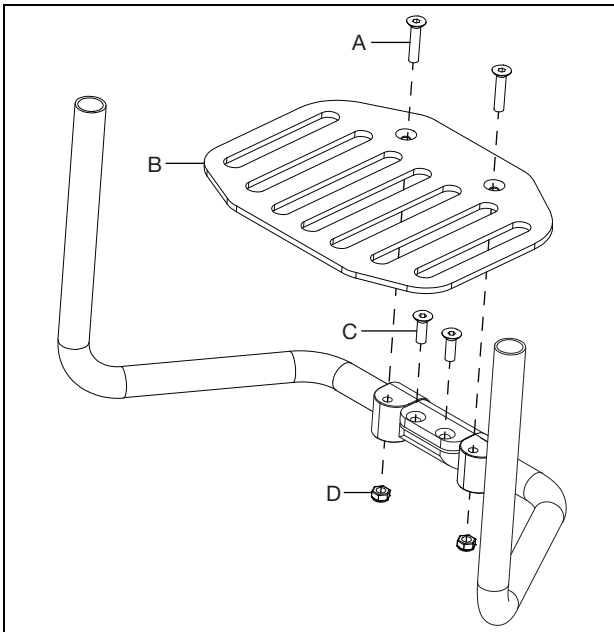

High Mount Angle Adjustable Footrest

1. Install the footrest tubes (A) into the footrest adjustable clamp (B) and secure by installing the footrest platform (C) onto the clamp with two screws (D) and two nuts (E) using a 5mm Allen wrench.

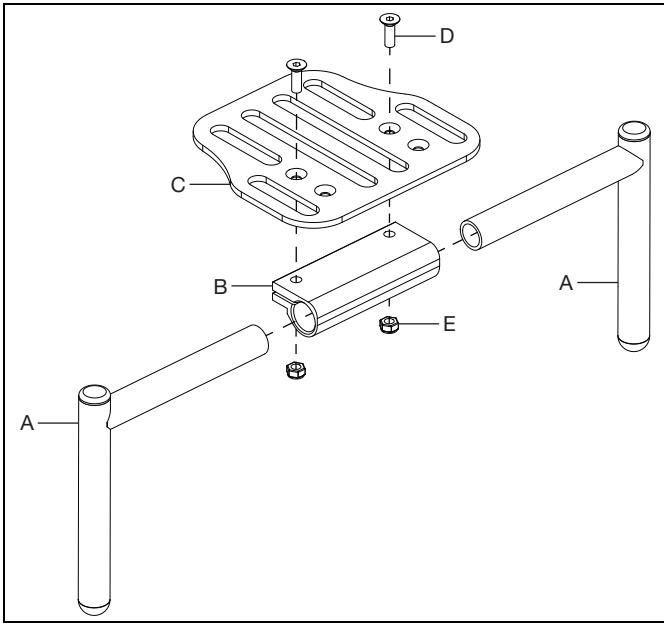

2. Install the two clamps (C & D), one end on the footrest tube and the other end around the frame tube, with two screws (A) and two lock washers (B) using a 5mm Allen wrench.

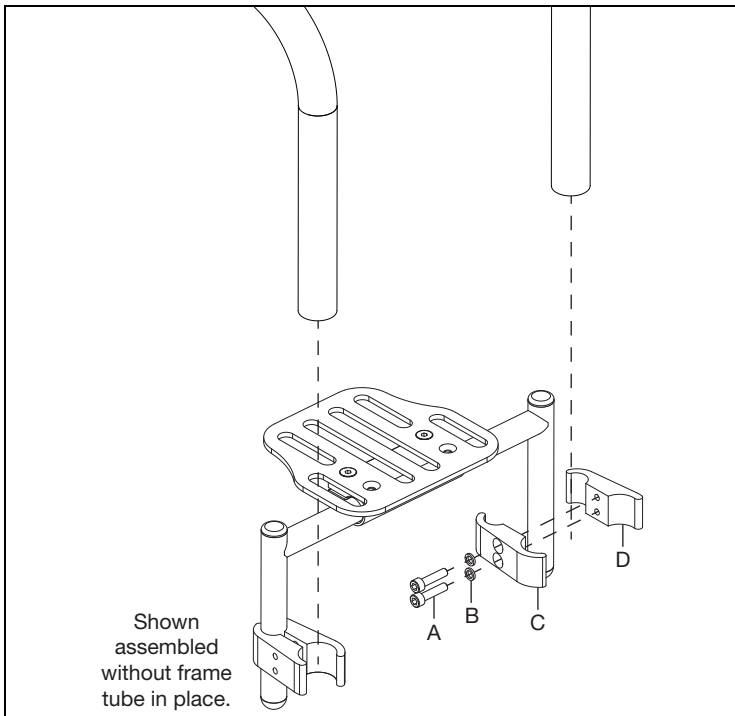

High Mount Angle Adjustable Flip Under Footrest

1. Install the pivots (B) and clamp (D) onto the footrest tube (A) and secure with two screws (C) using a 5mm Allen wrench.
2. Install the bracket (F) onto the end of the footrest tube and secure with screw (E) using a 4mm Allen wrench.
3. Install the footrest flip mount tube (H) onto the bracket with two screws (I) and two saddles (G) using a 4mm Allen wrench.

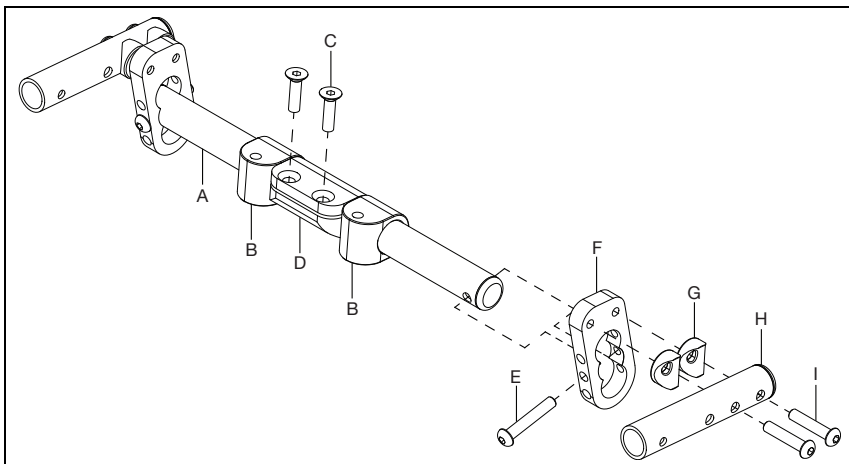

4. Install foot platform (C) onto pivots with two screws (B) using a 5mm Allen wrench. While installing the foot platform, slide the flip foot strap (A) onto frame tube.
5. Install the top and bottom footplate clamps (E & F) onto the footrest tubes and the frame tubes with three screws (D & G) using a 4mm Allen wrench and a 5mm Allen wrench.

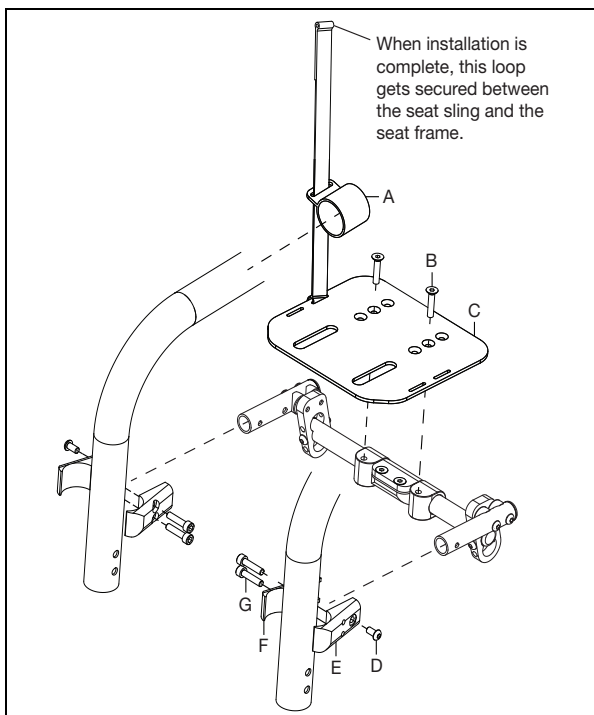

Adjusting the Footrest

NOTE: Some footrests are adjusted by moving the clamps they are attached with up or down. The standard footrest adjustment is shown below.

Height Adjustment of Footrest

1. Locate the set screw on each side of the frame.
2. Loosen the set screw on each side of the frame using a 3mm Allen wrench. Do not remove set screws all the way.
3. Adjust footrest tube up or down to achieve the desired height (B).
4. Ensure both sides are adjusted equally.
5. Retighten each set screw to 40 in./lbs.

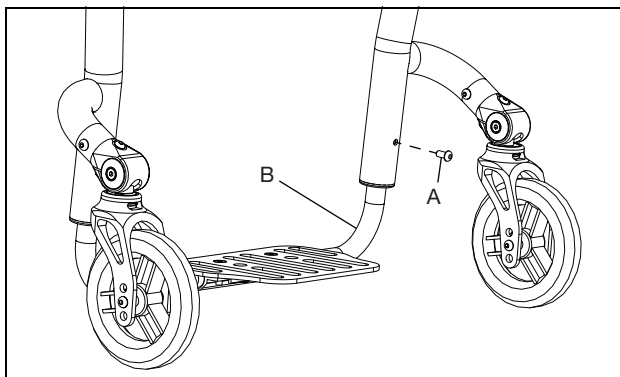

Rogue XP Frame Width

1. The Rogue XP frame width is changed with the frame connector (C), which is available in 0", 1", 2" and 3" lengths. Remove the four screws (A) and two threaded barrels (B) using two 4mm Allen wrenches to remove the frame connector. Swap in the new frame connector and reinstall hardware to secure.

NOTE: Other parts and assemblies on the chair need to be checked and/or adjusted when the width of the chair is changed. See the corresponding sections on the different parts and assemblies for information regarding installation and adjustments.

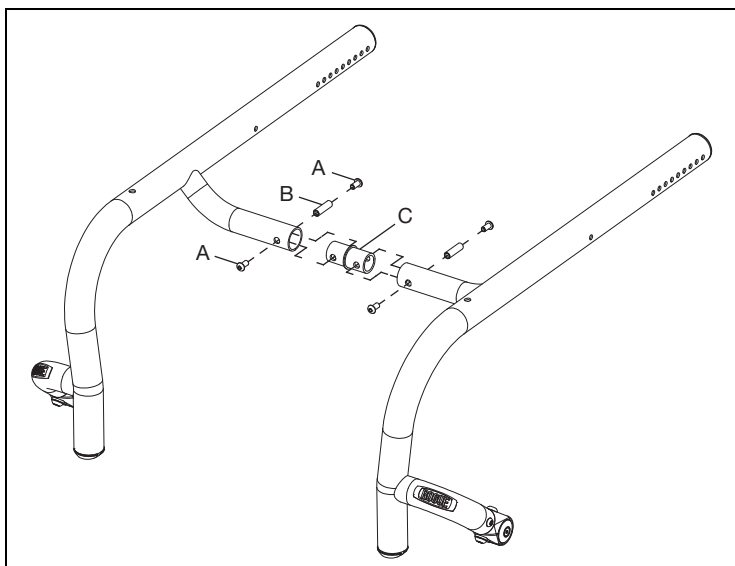

Anti-Tips

1. Assemble the anti-tip by connecting the two anti-tip tubes (B & C) and ensuring they "click" together when the detent buttons (A) engage.

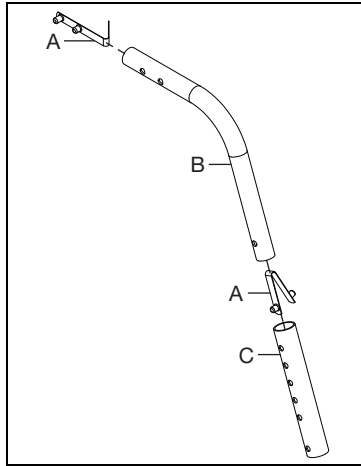

2. Install the wheels (B) onto the anti-tip tube with a bolt (C) and nut (A) using two 10mm wrenches.

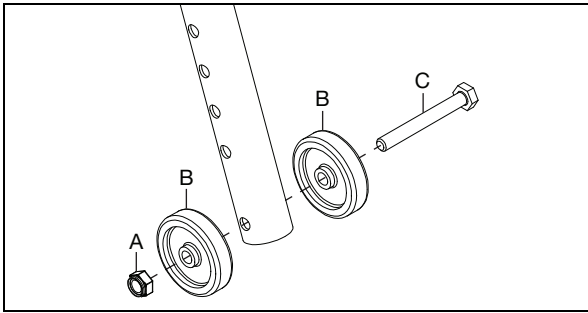

3. Install the anti-tip receiver (B) onto the camber tube mounting clamp with two screws (A) and two nuts (C) using a 4mm Allen wrench and an 8mm wrench. Install anti-tip assembly (D) into receiver until detent button "clicks" into place.

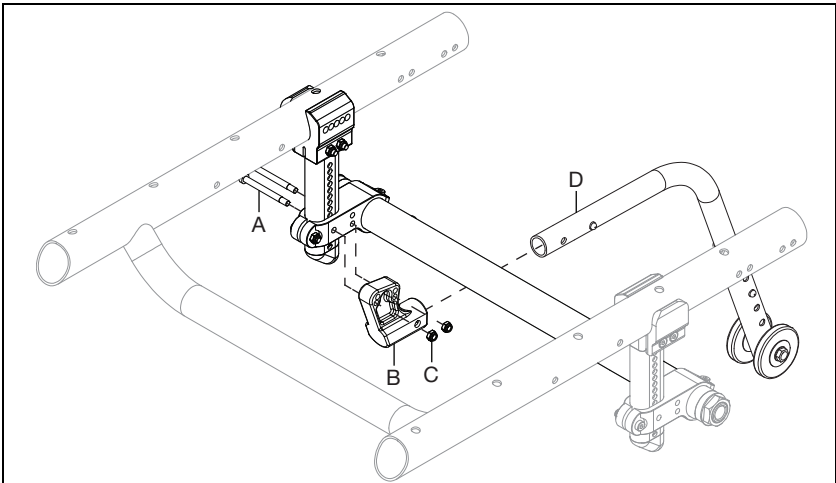

Rogue XP 5th Wheel

Standard 5th Wheel

1. Assemble the 5th wheel arm mount as shown below using two ½" wrenches.

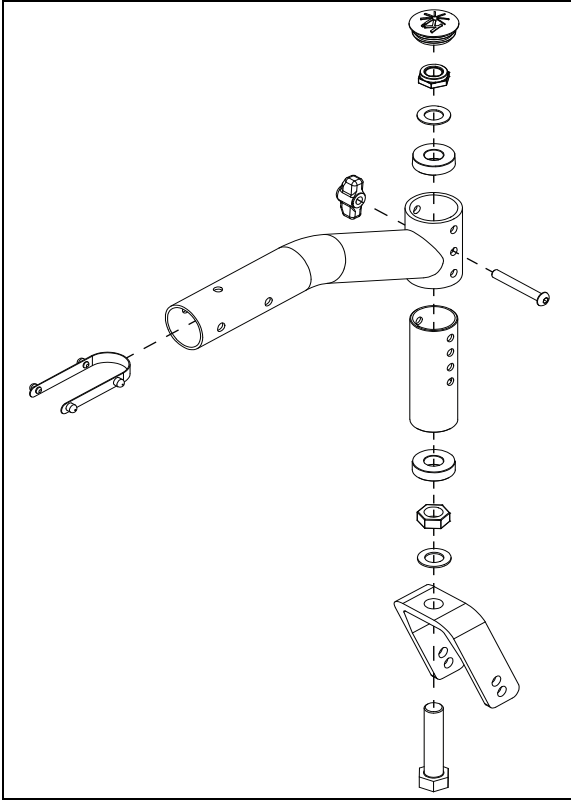

2. Install the caster (D) into the 5th wheel mount forks with two screws (A), threaded barrel (B) and two caster spacers (C) using two 4mm Allen wrenches.

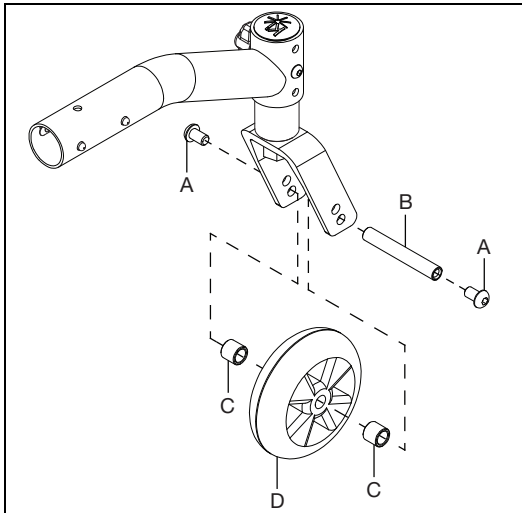

Rogue XP 5th Wheel

- Loosen the camber tube mount clamps by removing the bolt and nut from both sides using a 4mm Allen wrench and an 8mm wrench. Slide the camber tube halfway out as shown below.

NOTE: If you are retrofitting to the standard 5th wheel, remove the camber tube completely because a new camber tube is needed.

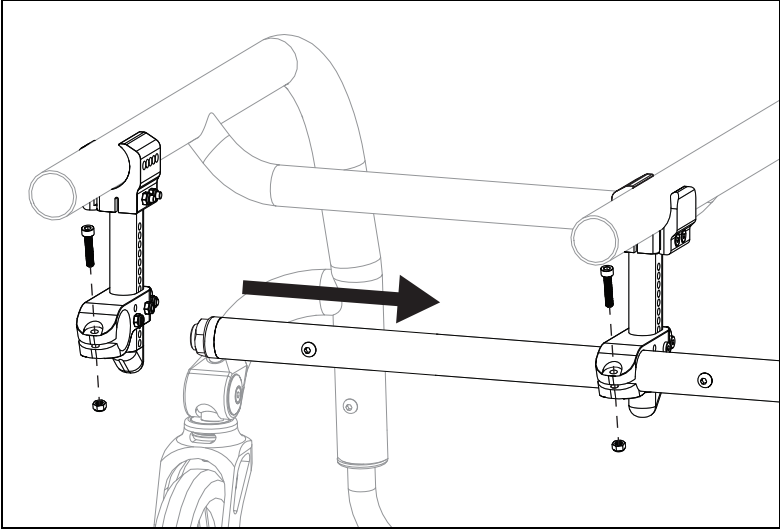

- Slide the 5th wheel mounting clamp (A) onto the camber tube. Slide the camber tube back to the standard position and reinstall hardware to secure the camber tube in place.

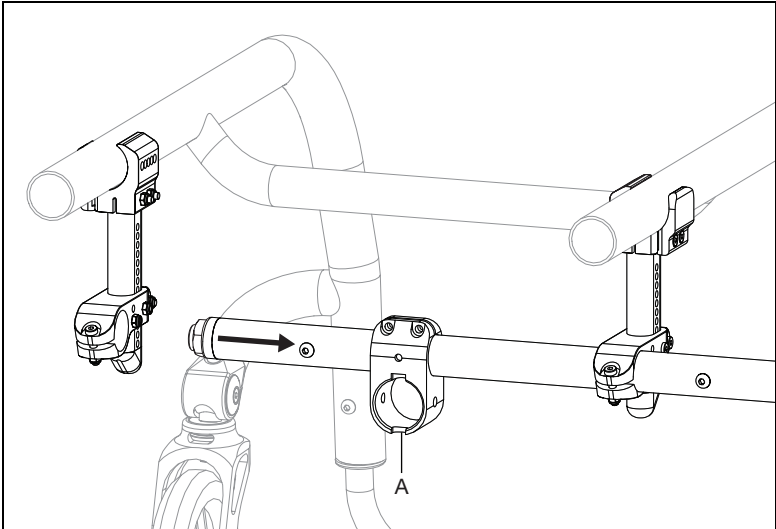

Rogue XP 5th Wheel

- Center the 5th wheel mounting clamp and secure in place by installing three screws (A & B) using a 4mm Allen wrench. Install the 5th wheel into the clamp and ensure the detent buttons "click" or lock into place.

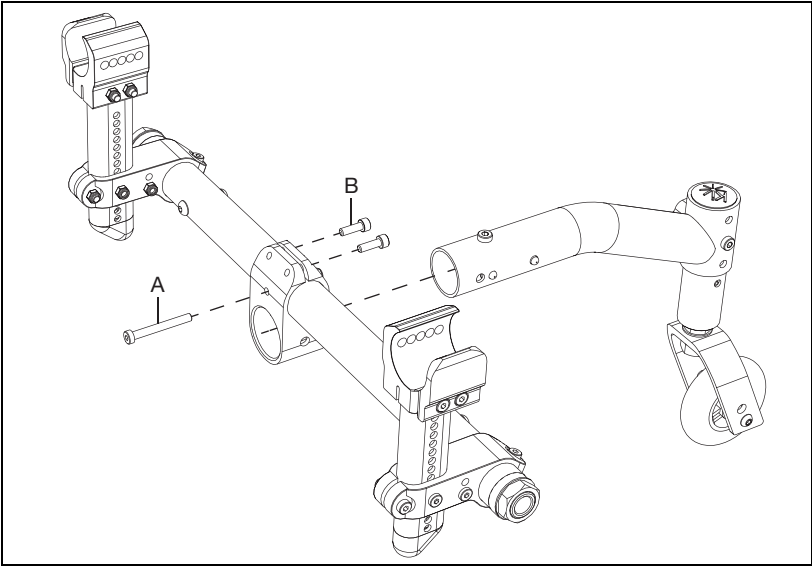

Dynamic 5th Wheel

- Assemble the 5th wheel arm mount as shown below using a 1/2" wrench, 10mm wrench and a 5mm Allen wrench.

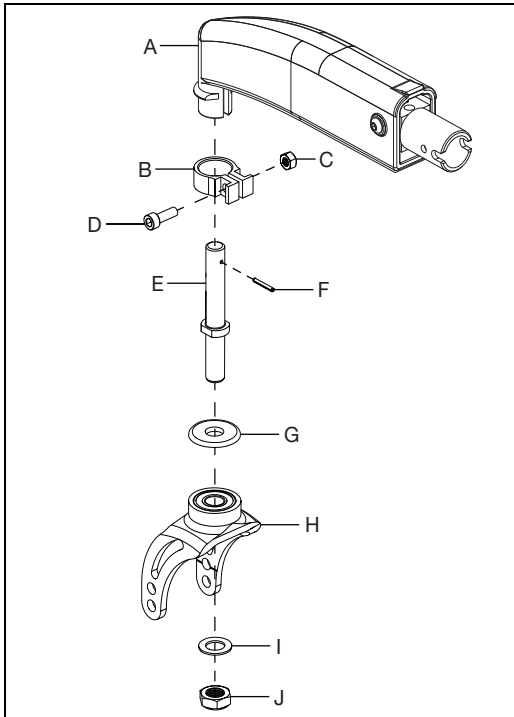

Rogue XP 5th Wheel

2. Install the caster (D) into the 5th wheel mount forks with two screws (A), threaded barrel (B) and two caster spacers (C) using two 4mm Allen wrenches.

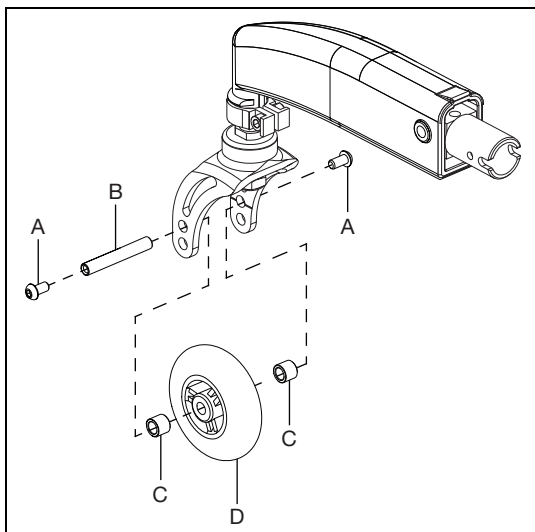

3. Loosen the camber tube mount clamps by removing the bolt and nut from both sides using a 4mm Allen wrench and an 8mm wrench. Slide the camber tube halfway out as shown below.

NOTE: If you are retrofitting to the dynamic 5th wheel, remove the camber tube completely because a new camber tube is needed.

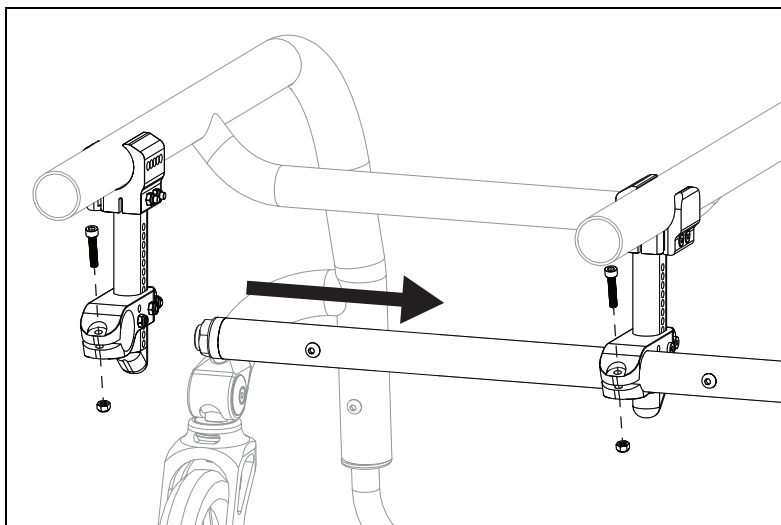

Rogue XP 5th Wheel

- Slide the 5th wheel mounting clamp (A) onto the camber tube. Slide the camber tube back to the standard position and reinstall hardware to secure the camber tube in place.

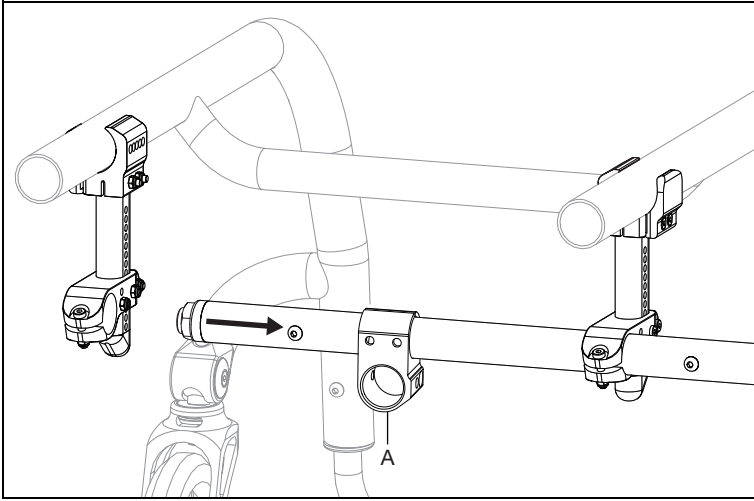

- Center the dynamic 5th wheel mounting clamp and secure in place by installing two screws (D), two washers (B) and two nuts (A) using a 5mm Allen wrench and a 10mm wrench. Install the two screws (F), a threaded barrel (E) and indexing plunger (G) using two 3mm Allen wrenches. Install the 5th wheel into the clamp and secure in place by pulling the index plunger out, inserting the 5th wheel and then releasing the index plunger. The index plunger secures the 5th wheel in place when reinserted into the 5th wheel tube hole.

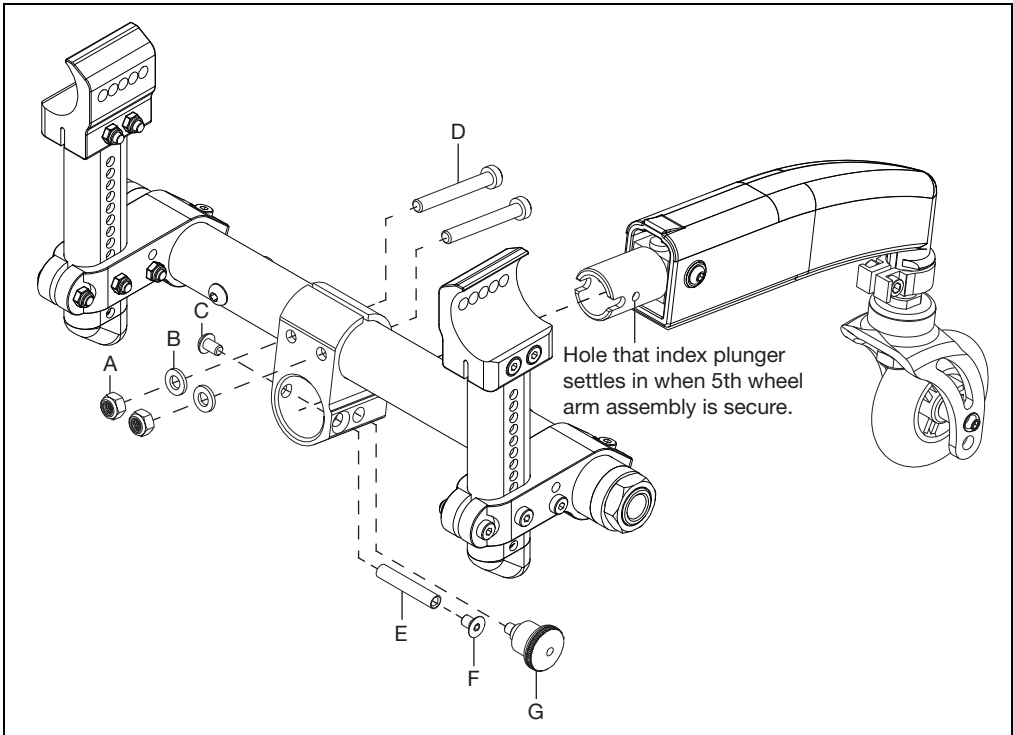

Rogue XP 5th Wheel

Inserting and Removing the Dynamic 5th Wheel

1. To remove, pull the release knob (A) to disengage the locking pin and slide assembly out of the tubular receiver (B).
2. To insert assembly, pull release knob (A) and insert assembly into tubular receiver (B).
3. Rotate the assembly in receiver to align slot (C) and cross pin (D).
4. Release knob (A).

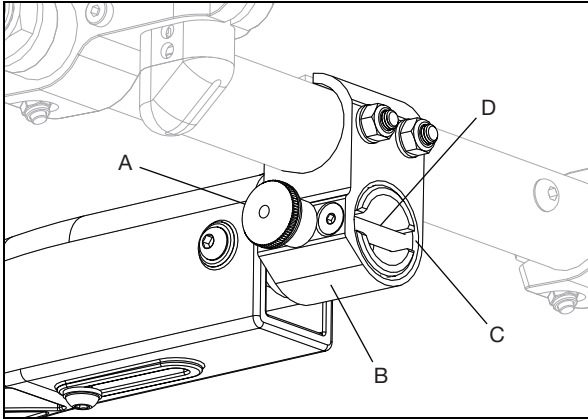

Adjusting the Position from the Floor

1. The caster stem is adjustable within the Dynamic 5th wheel arm.
2. Loosen 6mm bolt in clamping ring (A).
3. Grasp caster fork assembly and move up or down to desired position. Take care to not rotate caster stem within housing while repositioning.
4. Retighten 6mm bolt in clamping ring (A).

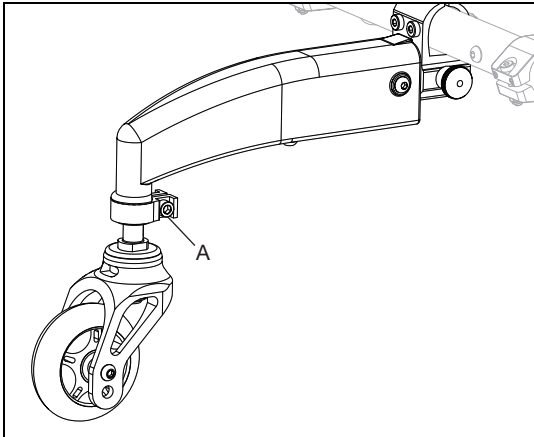

Rogue XP 5th Wheel

Adjusting Spring Force

1. Remove Dynamic 5th wheel assembly from chair.
2. Loosen 6mm screw located on the underside of assembly (Fig. 47:A).
3. To decrease spring rate, slide screw and elastomer away from caster fork assembly. To increase spring rate, slide screw and elastomer towards caster fork assembly.
4. Retighten 6mm screw (Fig. 47:A). Take care to not overtighten.

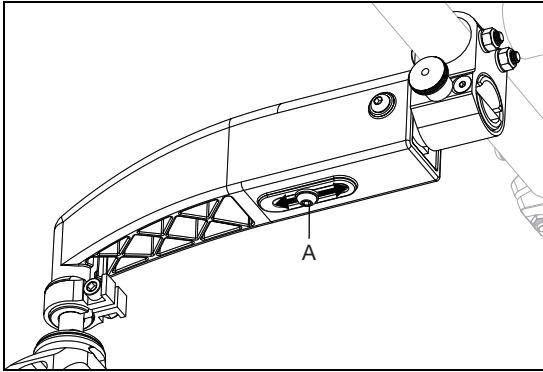

Changing or Replacing Elastomer

NOTE: There are two elastomers to choose from - a soft (yellow) and a firm (black). The softer elastomer (yellow) offers less resistance to the rider so it will move up and down easier when weight is applied to the system. The firmer elastomer (black) offers more resistance to the rider so it will not move as much when weight is applied to the system.

1. Remove dynamic 5th wheel assembly from chair.
2. Remove screw (A) using two 4mm Allen wrenches.
3. Using Allen wrench, push threaded barrel (B) out of arm assembly.
4. Slide tubular receiver (C) out of assembly.
5. Remove screw (F) and washer (E) located on the underside of assembly. This will release the elastomer (D). Remove elastomer and set aside.
6. Insert new elastomer (D) into opening on arm assembly with threaded insert facing down towards slot, aligned with slot in arm.
7. Thread screw (F) and washer (E) through slot and into threaded insert in elastomer. Retighten screw, but do not overtighten.
8. Reinsert tubular receiver (C) into arm. Take care to place flat arm of tubular receiver over the top of elastomer.
9. Align holes on arm and tubular receiver to insert threaded barrel (B) and screw (A).
10. Tighten the two screws (A) with two 4mm Allen wrenches.

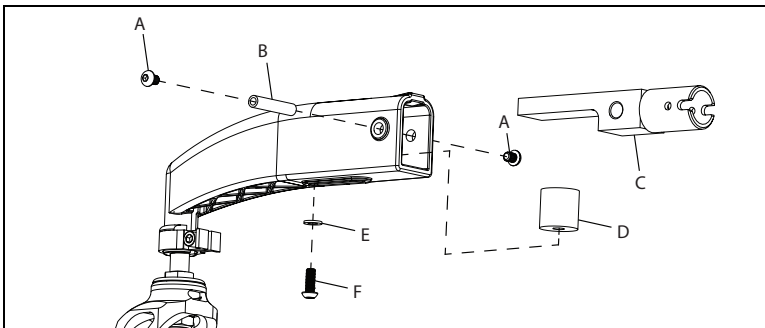

Wheel Locks

See image below for information on the types of wheel locks available. Installation of the wheel lock clamps is on the next page. The Under Seat Scissor Lock always comes assembled so it is not shown below.

Push to Lock Flush Mount

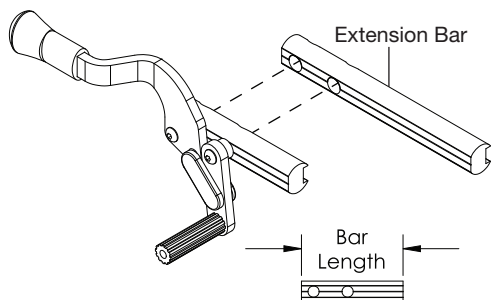

Part #	Bar	Length
N/A	Standard	3.5"
000904	Extended	6.0"

Low Profile Scissor Lock

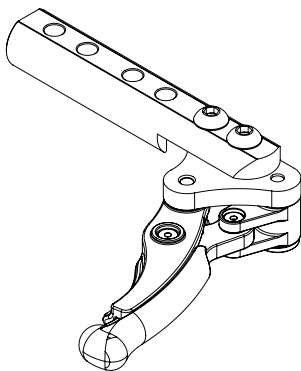

Short Thru Scissor Locks

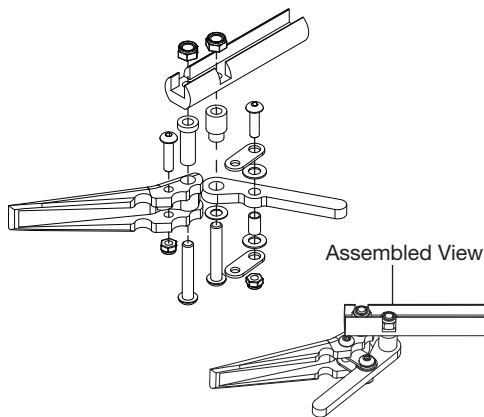

Grade Aids

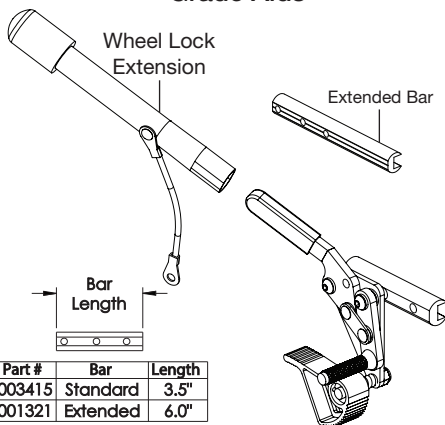

Part #	Bar	Length
003415	Standard	3.5"
001321	Extended	6.0"

Push and Pull to Lock Wheel Locks

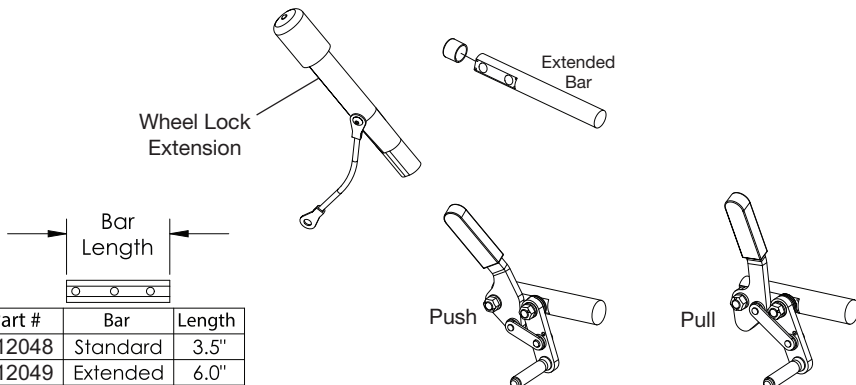

Part #	Bar	Length
112048	Standard	3.5"
112049	Extended	6.0"

Wheel Locks

Installing Wheel Lock Clamps

1. The wheel lock assemblies with the wheel lock bars are mounted onto the chair using the wheel lock clamps (C & D). There are two types of wheel lock clamps that are shown below. Install hardware with the wheel lock bar and chair frame in position using a 5mm Allen wrench and a 6mm Allen wrench. Once installed, ensure wheel lock engages at least 1/8" into tire and locks properly prevent the chair from moving when engaged.

NOTE: Always tighten wheel lock hardware by alternating between hardware while tightening a little at a time. This prevents overclamping on one set of hardware which can lead to binding of the fasteners and increased difficulty in removal.

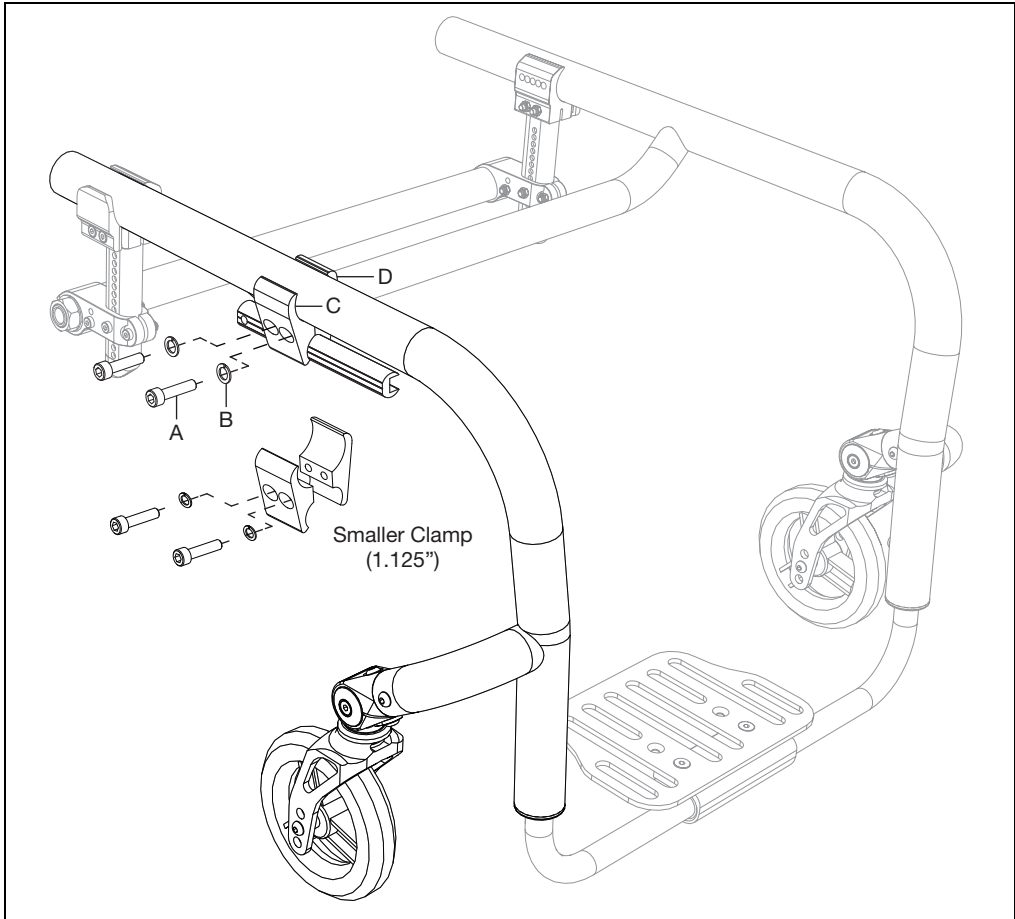

Reversing Wheel Lock

1. Identify the type of wheel lock on the chair.

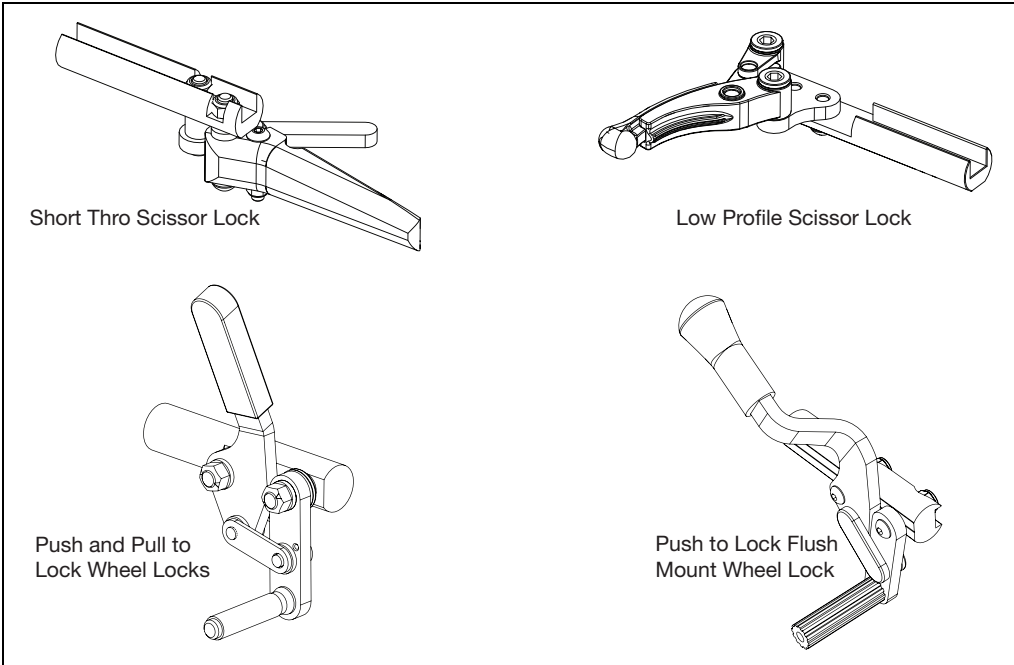

2. Remove wheel lock (D) and wheel lock bar (E) from clamp (C) by removing the two bolts (A) and two lock washers (B) with a 5mm Allen wrench.

NOTE: The push to lock flush mount is shown below. The process of removing the clamp is the same for all of the wheel locks.

NOTE: Always loosen wheel lock hardware by alternating between the two bolts while loosening a little at a time. This prevents overclamping on one set of hardware which can lead to binding of the fasteners and increased difficulty in removal.

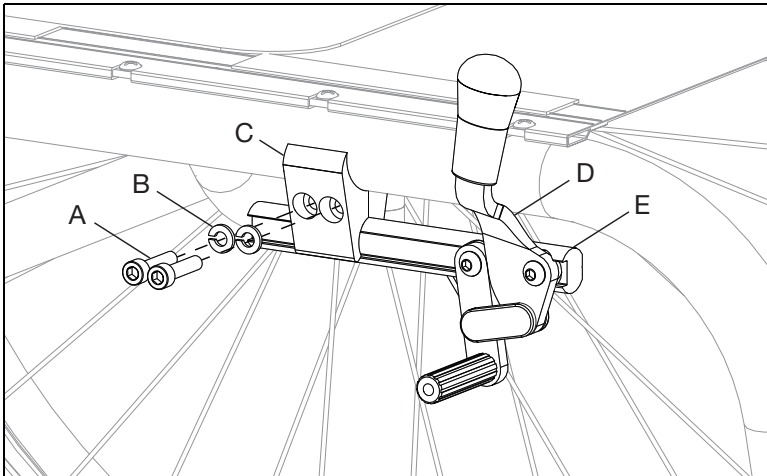

Reversing Wheel Lock

3. Remove the wheel lock assembly from the wheel lock bar. For a low profile scissor lock, use a 5mm Allen wrench to remove the two bolts. For the short throw and push to lock flush mount, remove hardware using a 4mm Allen wrench and a 10mm wrench. For the push and pull to lock, loosen and remove the top lock nuts and then grasp the assembly so the spring does not come out of the linkage hole when sliding off the arbors.

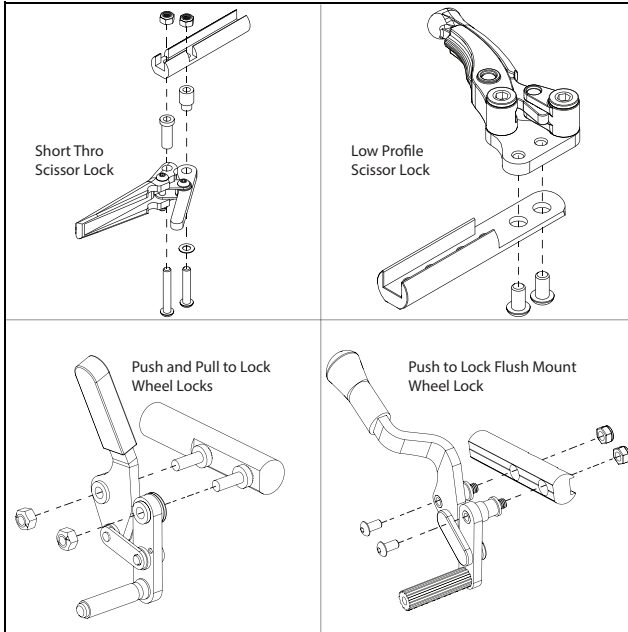

4. Rotate the wheel lock bar 180°.

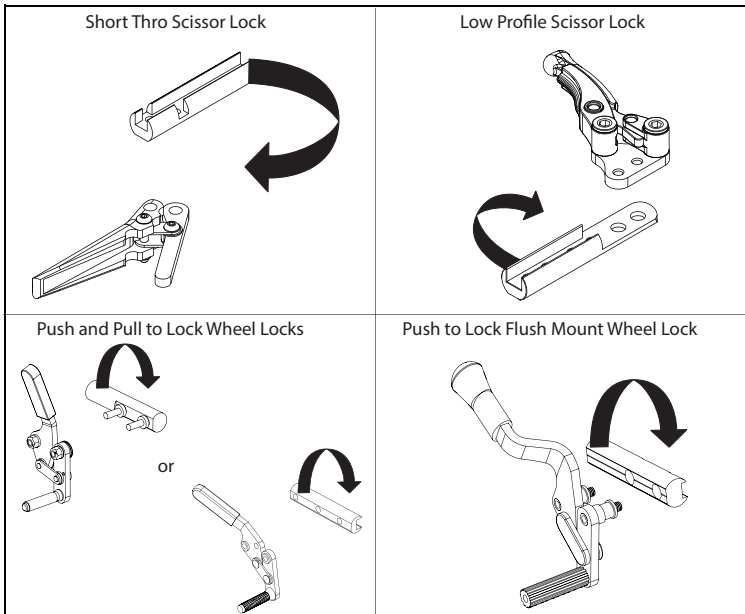

Reversing Wheel Lock

5. Reinstall the wheel lock assembly onto the wheel lock bar. For a low profile scissor lock, use a 5mm Allen wrench to install the two bolts. For the short throw and push to lock flush mount wheel locks, install hardware using a 4mm Allen wrench and a 10mm wrench. For the push and pull to lock, slide the assembly back onto the arbors. To install the spring on a push to lock, pull the curved spring arm over the arbor shoulder. To install the spring on a pull to lock, pull the spring arm end into the wheel lock bar hole (thin screwdriver will help with this). Place and tighten the top lock nuts to secure. See image below.

NOTE: Always tighten wheel lock hardware by alternating between the two bolts while tightening a little at a time. This prevents overclamping on one set of hardware which can lead to binding of the fasteners and increased difficulty in removal.

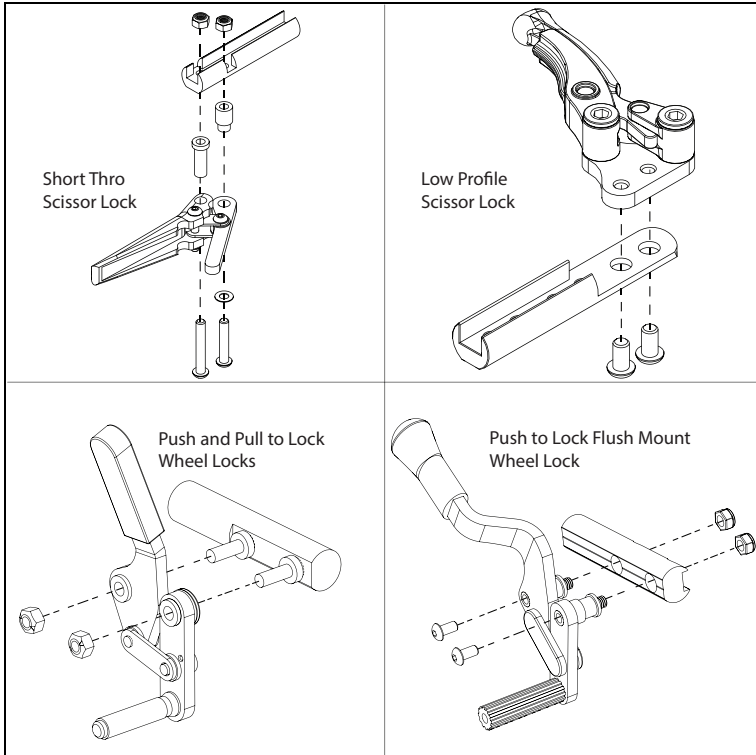

6. Test the wheel locks. Ensure wheel lock arms embed in tires at least 1/8 inch when locked. If they do not embed at least 1/8 inch, readjust wheel lock and test again.

Center of Gravity Adjustment

You can adjust your center of gravity by moving the two camber mount clamps (A) forward or rearward on the seat tube (B). Moving the camber mount clamps forward shortens the wheelbase and lightens the front end, making your chair more maneuverable. Moving the camber mounts rearward makes the chair more stable and less likely to tip over rearward.

NOTE: Changes to the center of gravity may affect the rear seat height, toe-in/toe-out of the rear wheels and the squareness of the casters. If you change your center of gravity position, readjust all of these settings as necessary.

NOTE: Adjusting your chair's center of gravity will require readjusting the location of the wheel locks (if provided). See the Wheel Lock section for instructions on adjusting the wheel locks.

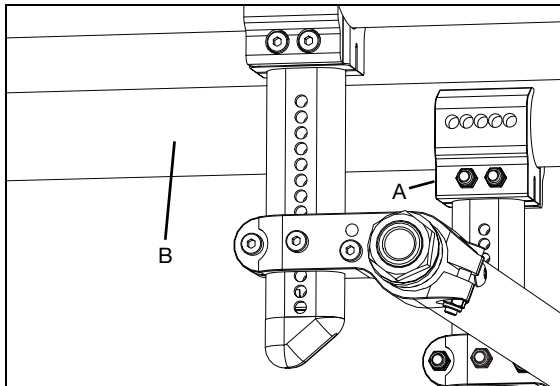

To adjust the center of gravity location:

NOTE: The outside clamp (B) is not used when the COG is set at -0.25 or less. The inside clamp is bolted directly onto the chair frame when outside clamp is not used.

NOTE: The outside clamp (B) is also not used when the tower has to be bolted to the frame in the same place as the backrest plate. See example image below.

NOTE: Every Rogue frame that has the Drive Ready option has the COG system bolted to the frame instead of using the clamp system.

- Remove both rear wheels.
- Loosen the two screws (C) and nuts that secure the camber mounts (A & B) to the seat tubes.
- Slide the camber mounts forward or rearward along the seat tube to the desired hole location.
- Repeat on the other side.
- Ensure the mounts on both sides of the frame are adjusted equally on both sides of the frame before tightening all the screws and nuts.
- Once the camber mount clamps are secured, attach the rear wheels, occupy the chair and maneuver it with a spotter to get a feel for the new adjustment.

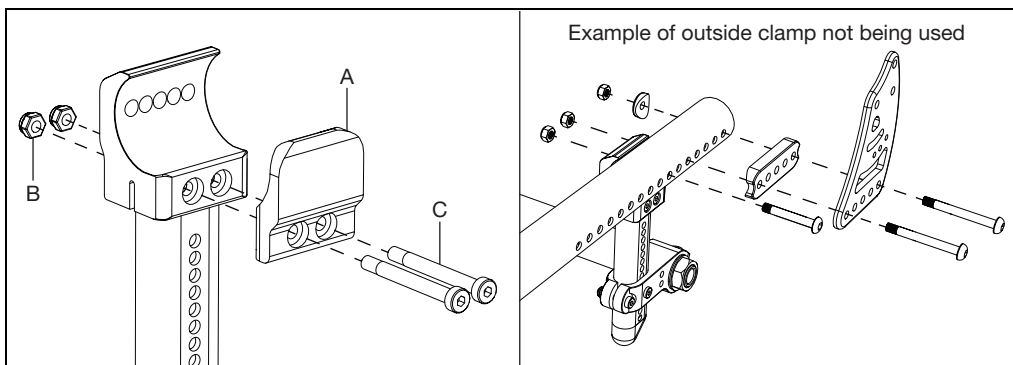

Seat Height Adjustment

Rear Seat Height

Rear seat height can be adjusted by repositioning the Tubular Component System (TCS).

1. Remove your wheels by depressing the buttons on the quick release axle.
2. Use a 4mm Allen wrench and 8mm open end wrench to remove the two bolts (A) holding the upper and lower mounting brackets together. Reposition the mounting brackets to the desired height and replace the two M5 bolts.
3. Repeat on both sides of the wheelchair.

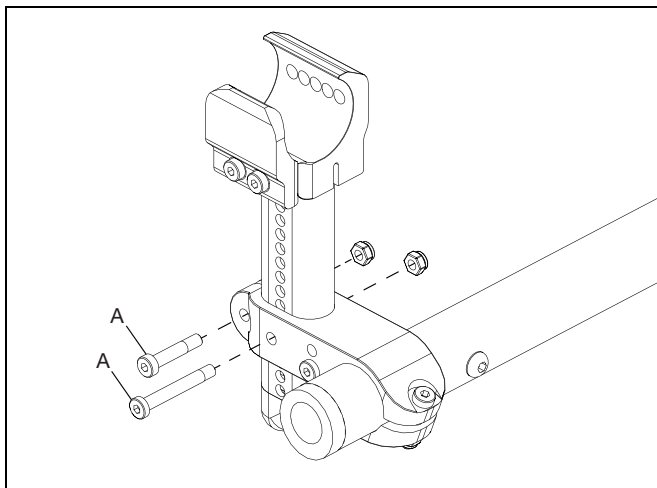

NOTE: Height adjustments are in ¼" increments.

NOTE: A front caster adjustment should be made to correspond with any change in seat angle.

Front Seat Height

The front seat height can be adjusted in ½" increments by repositioning the caster wheel within the fork.

1. Use two 4mm Allen wrenches to remove the cap screws and push the internally threaded axle from one hole location and move up or down to the desired location.
2. Reposition the two 6mm screws and tighten to 80 in./lbs.
3. Resquare caster wheels.

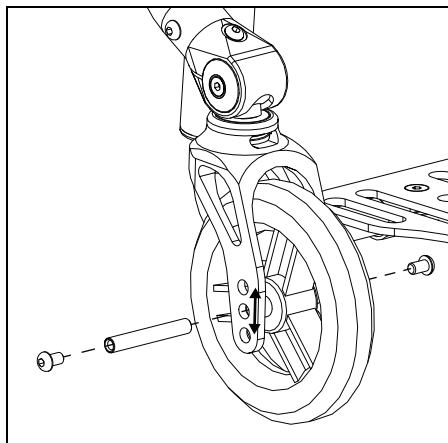

Setting Toe to Zero

NOTE: A wheelchair equipped with 0° camber plugs cannot have a toe-in toe-out condition. This adjustment is only required when using 2°, 4°, 6° and 8° camber adapters.

Toe refers to how well the rear wheels of the chair are aligned relative to the ground. It affects how well the chair will roll. Drag or rolling resistance is optimally minimized when the wheel toe is set to zero.

To Set Toe to Zero:

1. Loosen the cap screws (A) (1 per side) that secure the camber tube clamp.
2. Rotate the camber tube (B) until the screws (C) that secure the camber studs are level with the ground. The toe is now set at zero.
3. Before tightening the screws (A), make certain that the camber tube is centered left-to-right relative to the wheelchair frame. There should be an equal gap on both sides or none at all.
4. Tighten screws in a balanced fashion - tighten one screw to 50 in./lbs and then the second to 50 in./lbs. Return to tighten the first screw to 80 in./lbs. and finally the second screw to 80 in./lbs. Repeat on opposite side.

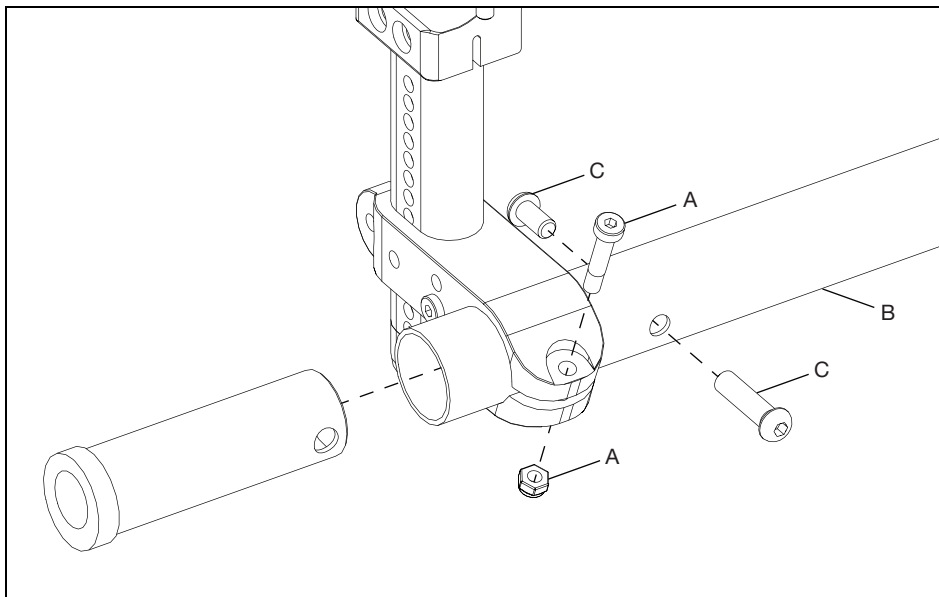

Wheelbase Width Adjustment

Adjusting the wheelbase width allows the rider the option to move the wheels closer or further away from the hips. It also compensates for camber adjustment and gives the proper wheel spacing to maximize pushing efficiency.

To Adjust the Wheelbase Width

1. Loosen the nut (A) with a 24mm wrench and turn the threaded axle sleeve (B) in or out to desired width.
2. Retighten nut.
3. Repeat on opposite side.

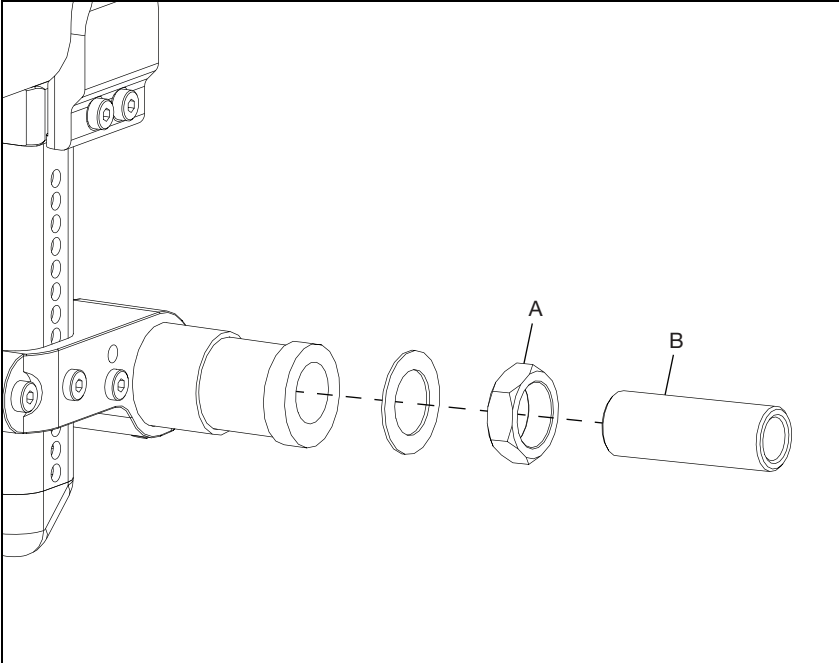

One Arm Drive (OAD)

Installation

1. Remove wheels, camber tube and camber tube mount clamps.
2. Install the camber tube mount clamps (F) onto the existing camber towers (A) using three bolts (D & B) and three nuts (E) using a 4mm Allen wrench and an 8mm wrench. The holes used to install the camber mount clamp onto the camber tower determines seat height. Use the holes that provide the desired seat height for the user.
3. The axle mount (C) must be mounted reverse of how it is shown in Fig. 1 when using 2 degrees or greater camber. Remove the bolt (B) and nut (E) using a 4mm Allen wrench and an 8mm wrench, reverse the axle mount and reinstall hardware.

NOTE: The completed camber tower assembly is shown pointing forward in image below. If a 5th wheel is being used, the camber tower assembly will be pointed rearward.

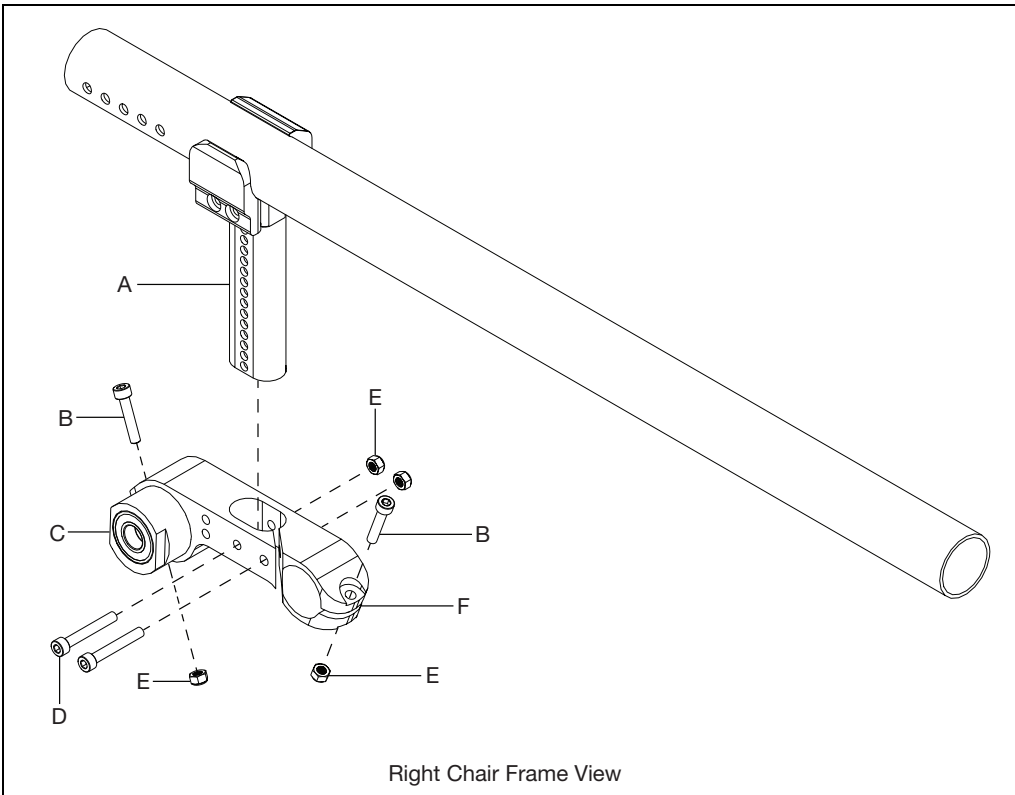

One Arm Drive (OAD)

4. Install the camber mount clamp on the opposite side the same way as steps 2 and 3. Before fully tightening, install the OAD drive shaft (A) into the two axle mounts.

NOTE: See tables at the end of these instructions for the drive shaft lengths used in different configurations.

NOTE: Some configurations require one wheel to be installed, then the drive shaft, then the opposite wheel. These configurations are called out in the Shaft Reference at the end of these instructions.

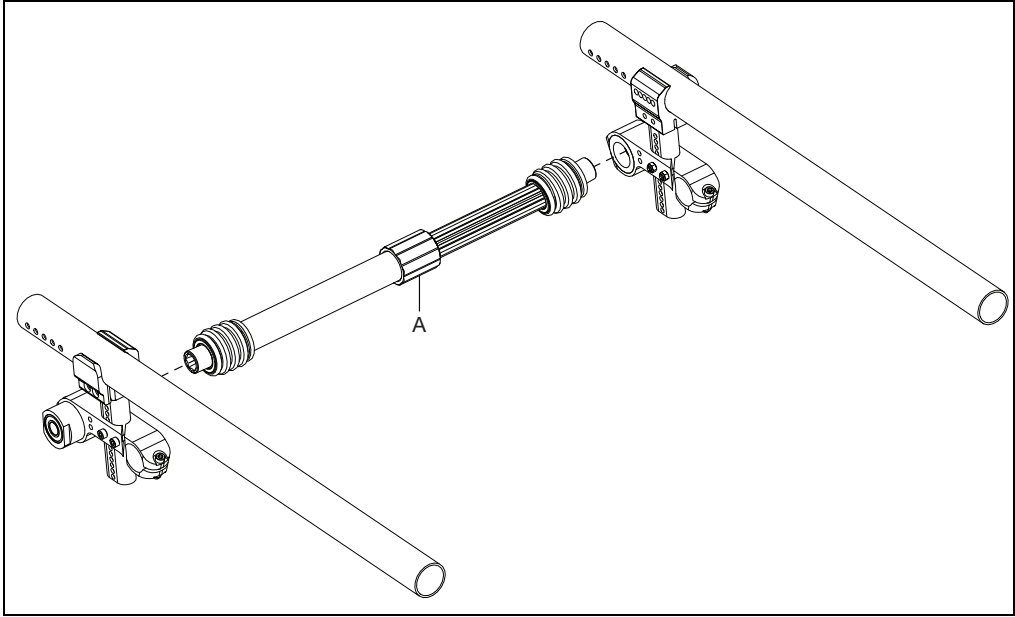

5. Install the OAD wheels on both sides of chair. Install the OAD wheel with the handrim (A) on the desired drive side. The OAD wheel with no handrim (B) is the following side and is installed opposite the drive wheel.

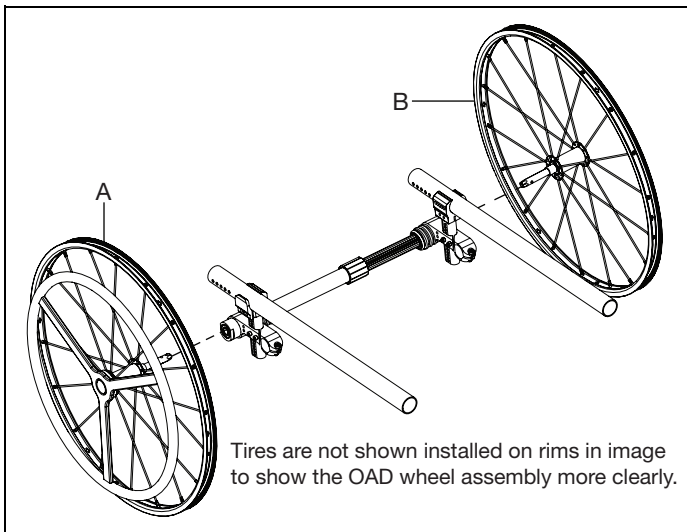

ROGUE SEAT WIDTH		DRIVE SHAFT LENGTH BY CONFIGURATION			PART NUMBER
WHEEL SPACING	CAMBER	DESCRIPTION			
SEAT WIDTH 11"	1.75	0	QUICK RELEASE OAD ZERO CAMBER DRIVE SHAFT 177-255MM	-111503	
	0.75, 1	2	QUICK RELEASE OAD UNIVERSAL DRIVE SHAFT 170-195MM	#111958	
	1.25	2	QUICK RELEASE OAD UNIVERSAL DRIVE SHAFT 180-210MM	#111827	
	1.75	2	QUICK RELEASE OAD UNIVERSAL DRIVE SHAFT 195-235MM	#111828	
SEAT WIDTH 12"	1	4	QUICK RELEASE OAD UNIVERSAL DRIVE SHAFT 195-235MM	#111828	
	1.5	0	QUICK RELEASE OAD ZERO CAMBER DRIVE SHAFT 177-255MM	111503	
	1.75	0	QUICK RELEASE OAD ZERO CAMBER DRIVE SHAFT 177-255MM	-111503	
	0.75, 1	2	QUICK RELEASE OAD UNIVERSAL DRIVE SHAFT 180-210MM	#111827	
SEAT WIDTH 13"	1.25, 1.5	2	QUICK RELEASE OAD UNIVERSAL DRIVE SHAFT 195-235MM	111828	
	1.75	2	QUICK RELEASE OAD UNIVERSAL DRIVE SHAFT 220-280MM	-111498	
	0.75, 1	4	QUICK RELEASE OAD UNIVERSAL DRIVE SHAFT 195-235MM	111828	
	1, 1.25, 1.5	0	QUICK RELEASE OAD ZERO CAMBER DRIVE SHAFT 177-255MM	111503	
SEAT WIDTH 14"	1.75	0	QUICK RELEASE OAD ZERO CAMBER DRIVE SHAFT 225-295MM	-111504	
	0.75, 1	2	QUICK RELEASE OAD UNIVERSAL DRIVE SHAFT 195-235MM	111828	
	1.25, 1.5	2	QUICK RELEASE OAD UNIVERSAL DRIVE SHAFT 220-280MM	111498	
	1.75	2	QUICK RELEASE OAD UNIVERSAL DRIVE SHAFT 220-280MM	-111498	
SEAT WIDTH 14"	0.75, 1	4	QUICK RELEASE OAD UNIVERSAL DRIVE SHAFT 220-280MM	111498	
	1, 1.25	0	QUICK RELEASE OAD ZERO CAMBER DRIVE SHAFT 177-255MM	111503	
	1.5	0	QUICK RELEASE OAD ZERO CAMBER DRIVE SHAFT 225-295MM	111504	
	1.75	0	QUICK RELEASE OAD ZERO CAMBER DRIVE SHAFT 225-295MM	-111504	
SEAT WIDTH 14"	0.75, 1, 1.25	2	QUICK RELEASE OAD UNIVERSAL DRIVE SHAFT 220-280MM	111498	
	1.5	2	QUICK RELEASE OAD UNIVERSAL DRIVE SHAFT 270-330MM	#111499	
	1.75	2	QUICK RELEASE OAD UNIVERSAL DRIVE SHAFT 270-330MM	-111499	
	0.75, 1	4	QUICK RELEASE OAD UNIVERSAL DRIVE SHAFT 270-330MM	#111499	
SEAT WIDTH 15"	1, 1.25, 1.5	0	QUICK RELEASE OAD ZERO CAMBER DRIVE SHAFT 225-295MM	111504	
	1.75	0	QUICK RELEASE OAD ZERO CAMBER DRIVE SHAFT 280-370MM	-111505	
	0.75	2	QUICK RELEASE OAD UNIVERSAL DRIVE SHAFT 220-280MM	111498	
	1	2	QUICK RELEASE OAD UNIVERSAL DRIVE SHAFT 270-330MM	#111499	
SEAT WIDTH 15"	1.25, 1.5	2	QUICK RELEASE OAD UNIVERSAL DRIVE SHAFT 270-330MM	111498	
	1.75	2	QUICK RELEASE OAD UNIVERSAL DRIVE SHAFT 350-460MM	-111500	
	0.75, 1	4	QUICK RELEASE OAD UNIVERSAL DRIVE SHAFT 270-330MM	111498	

NOTES:

#FOR THIS CONFIGURATION, ONE WHEEL MUST BE REMOVED BEFORE THE DRIVESHAFT CAN BE INSTALLED. THE SECOND WHEEL CAN BE INSTALLED ONCE THE DRIVE SHAFT IS IN POSITION.
 -FOR THIS CONFIGURATION, TOWER ASSEMBLIES ARE TO BE MOUNTED OUTBOARD OF THE FRAME.

DRIVE SHAFT LENGTH BY CONFIGURATION					PART NUMBER
ROGUE SEAT WIDTH	WHEEL SPACING	CAMBER	DESCRIPTION		
SEAT WIDTH 16"	1	0	QUICK RELEASE OAD ZERO-CAMBER DRIVE SHAFT 295-293MM	111504	
	1.25, 1.5	0	QUICK RELEASE OAD ZERO-CAMBER DRIVE SHAFT 280-370MM	111505	
	1.75	0	QUICK RELEASE OAD ZERO-CAMBER DRIVE SHAFT 280-370MM	-111505	
	0.75, 1	2	QUICK RELEASE OAD UNIVERSAL DRIVE SHAFT 270-330MM	111499	
	1.25, 1.5	2	QUICK RELEASE OAD UNIVERSAL DRIVE SHAFT 295-370MM	111500	
SEAT WIDTH 17"	1.75	2	QUICK RELEASE OAD UNIVERSAL DRIVE SHAFT 295-370MM	111500	
	0.75, 1, 1.25, 1.5	2	QUICK RELEASE OAD UNIVERSAL DRIVE SHAFT 350-460MM	-111501	
	1.75	2	QUICK RELEASE OAD UNIVERSAL DRIVE SHAFT 295-370MM	111500	
	0.75, 1	4	QUICK RELEASE OAD UNIVERSAL DRIVE SHAFT 350-460MM	111500	
	1, 1.25	0	QUICK RELEASE OAD ZERO-CAMBER DRIVE SHAFT 280-370MM	111505	
SEAT WIDTH 18"	1.5	0	QUICK RELEASE OAD ZERO-CAMBER DRIVE SHAFT 330-410MM	111506	
	1.75	0	QUICK RELEASE OAD ZERO-CAMBER DRIVE SHAFT 330-410MM	-111506	
	0.75, 1	2	QUICK RELEASE OAD UNIVERSAL DRIVE SHAFT 295-370MM	111500	
	1.25, 1.5	2	QUICK RELEASE OAD UNIVERSAL DRIVE SHAFT 350-460MM	111501	
	1.75	2	QUICK RELEASE OAD UNIVERSAL DRIVE SHAFT 350-460MM	-111501	
SEAT WIDTH 19"	0.75	2	QUICK RELEASE OAD UNIVERSAL DRIVE SHAFT 295-370MM	111500	
	1	2	QUICK RELEASE OAD UNIVERSAL DRIVE SHAFT 270-330MM	111498	
	1.25	2	QUICK RELEASE OAD UNIVERSAL DRIVE SHAFT 295-370MM	111500	
	1.5	2	QUICK RELEASE OAD UNIVERSAL DRIVE SHAFT 350-460MM	111501	
	0.75, 1	2	QUICK RELEASE OAD UNIVERSAL DRIVE SHAFT 350-460MM	-111501	
SEAT WIDTH 20"	1, 1.25, 1.5	0	QUICK RELEASE OAD ZERO-CAMBER DRIVE SHAFT 330-410MM	111506	
	1.75	0	QUICK RELEASE OAD ZERO-CAMBER DRIVE SHAFT 330-410MM	-111506	
	0.75	2	QUICK RELEASE OAD UNIVERSAL DRIVE SHAFT 270-330MM	111498	
	1	2	QUICK RELEASE OAD UNIVERSAL DRIVE SHAFT 270-330MM	111498	
	1.25	2	QUICK RELEASE OAD UNIVERSAL DRIVE SHAFT 295-370MM	111500	
SEAT WIDTH 20"	1.5	2	QUICK RELEASE OAD UNIVERSAL DRIVE SHAFT 350-460MM	111501	
	1.75	2	QUICK RELEASE OAD UNIVERSAL DRIVE SHAFT 350-460MM	-111501	
	0.75, 1	4	QUICK RELEASE OAD UNIVERSAL DRIVE SHAFT 350-460MM	111501	
	1, 1.25, 1.5	0	QUICK RELEASE OAD ZERO-CAMBER DRIVE SHAFT 330-410MM	111506	
	1.75	0	QUICK RELEASE OAD ZERO-CAMBER DRIVE SHAFT 330-410MM	-111506	
SEAT WIDTH 20"	0.75, 1, 1.25, 1.5	2	QUICK RELEASE OAD UNIVERSAL DRIVE SHAFT 350-460MM	111501	
	1.75	2	QUICK RELEASE OAD UNIVERSAL DRIVE SHAFT 420-530MM	-111502	
	0.75, 1	4	QUICK RELEASE OAD UNIVERSAL DRIVE SHAFT 350-460MM	111501	
	1, 1.25, 1.5	0	QUICK RELEASE OAD ZERO-CAMBER DRIVE SHAFT 330-410MM	111506	
	1.75	0	QUICK RELEASE OAD ZERO-CAMBER DRIVE SHAFT 330-410MM	-111507	

NOTES:

#FOR THIS CONFIGURATION, ONE WHEEL MUST BE REMOVED BEFORE THE DRIVESHAFT CAN BE INSTALLED. THE SECOND WHEEL CAN BE INSTALLED ONCE THE DRIVE SHAFT IS IN POSITION.

-FOR THIS CONFIGURATION, TOWER ASSEMBLIES ARE TO BE MOUNTED OUTBOARD OF THE FRAME.

DRIVE SHAFT CONFIGURATIONS FOR ROGUE WITH T-ARMS				
ROGUE SEAT WIDTH	WHEEL SPACING	CAMBER	DESCRIPTION	PART NUMBER
SEAT WIDTH 11"	1.75	0	QUICK RELEASE OAD ZERO CAMBER DRIVE SHAFT 177-255MM	111503
	1.75	2	QUICK RELEASE OAD UNIVERSAL DRIVE SHAFT 195-235MM	111628
SEAT WIDTH 12"	1.75	0	QUICK RELEASE OAD ZERO CAMBER DRIVE SHAFT 177-255MM	111503
	1.75	2	QUICK RELEASE OAD UNIVERSAL DRIVE SHAFT 220-280MM	111498
SEAT WIDTH 13"	1.75	0	QUICK RELEASE OAD ZERO CAMBER DRIVE SHAFT 225-295MM	111504
	1.75	2	QUICK RELEASE OAD UNIVERSAL DRIVE SHAFT 220-280MM	111498
SEAT WIDTH 14"	1.75	0	QUICK RELEASE OAD ZERO CAMBER DRIVE SHAFT 225-295MM	111504
	1.75	2	QUICK RELEASE OAD UNIVERSAL DRIVE SHAFT 270-330MM	111499
SEAT WIDTH 15"	1.75	0	QUICK RELEASE OAD ZERO CAMBER DRIVE SHAFT 260-370MM	111505
	1.75	2	QUICK RELEASE OAD UNIVERSAL DRIVE SHAFT 295-370MM	111500
SEAT WIDTH 16"	1.75	0	QUICK RELEASE OAD ZERO CAMBER DRIVE SHAFT 260-370MM	111505
	1.75	2	QUICK RELEASE OAD UNIVERSAL DRIVE SHAFT 350-460MM	111500
SEAT WIDTH 17"	1.75	0	QUICK RELEASE OAD ZERO CAMBER DRIVE SHAFT 330-440MM	111506
	1.75	2	QUICK RELEASE OAD UNIVERSAL DRIVE SHAFT 350-460MM	111501
SEAT WIDTH 18"	1.75	0	QUICK RELEASE OAD ZERO CAMBER DRIVE SHAFT 330-440MM	111506
	1.75	2	QUICK RELEASE OAD UNIVERSAL DRIVE SHAFT 350-460MM	111501
SEAT WIDTH 19"	1.75	0	QUICK RELEASE OAD ZERO CAMBER DRIVE SHAFT 330-440MM	111506
	1.75	2	QUICK RELEASE OAD UNIVERSAL DRIVE SHAFT 350-460MM	111501
SEAT WIDTH 20"	1.75	0	QUICK RELEASE OAD ZERO CAMBER DRIVE SHAFT 421-491MM	111507
	1.75	2	QUICK RELEASE OAD UNIVERSAL DRIVE SHAFT 420-530MM	111502

NOTE: TOWER ASSEMBLIES ARE TO BE MOUNTED OUTBOARD OF THE FRAME WHEN T-ARMS ARE USED.

Growing Your Rogue XP in Width

It is recommended that you follow the below sequence of adjustments when growing your Rogue XP in width.

Remove the following assemblies from chair in order listed:

1. Upholstery - See seat upholstery section on page 33.
2. Backrest Release Cable - See backrest assembly section on page 16. Use the section that corresponds with the backrest assembly style found on the chair.
3. Rigidizer Bar - See back post section which begins on page 20. Use the section that corresponds with the back post style found on the chair.
4. Footrest Assembly - See footrest section which begins on page 40. Use the section that corresponds with the footrest assembly style found on the chair.
5. Camber Tube - See camber mount assembly and camber tube and adapters section which begins on page 13.

Replace new assemblies for width adjustment in reverse of order listed above. Reference removal and replacement instructions.

Drum Brake

NOTE: Remove wheels and axle sleeves before beginning the drum brake instructions.

1. Install the drum brake adapter (F) to the drum brake rotor (E) with bolt (A), washer (B) and nut (G) using two 10mm wrenches. Thread the pinch bolt (C) into the drum brake arm.
2. Install the drum brake rotor assembly to the axle plate with axle receiver nut (D), axle sleeve (H), camber adapter (I), two bolts (J) and threaded barrel (K) using two adjustable wrenches and two 5mm Allen wrenches.

NOTE: The drum brake orientation varies depending on the camber tower position. See the diagrams below for additional information.

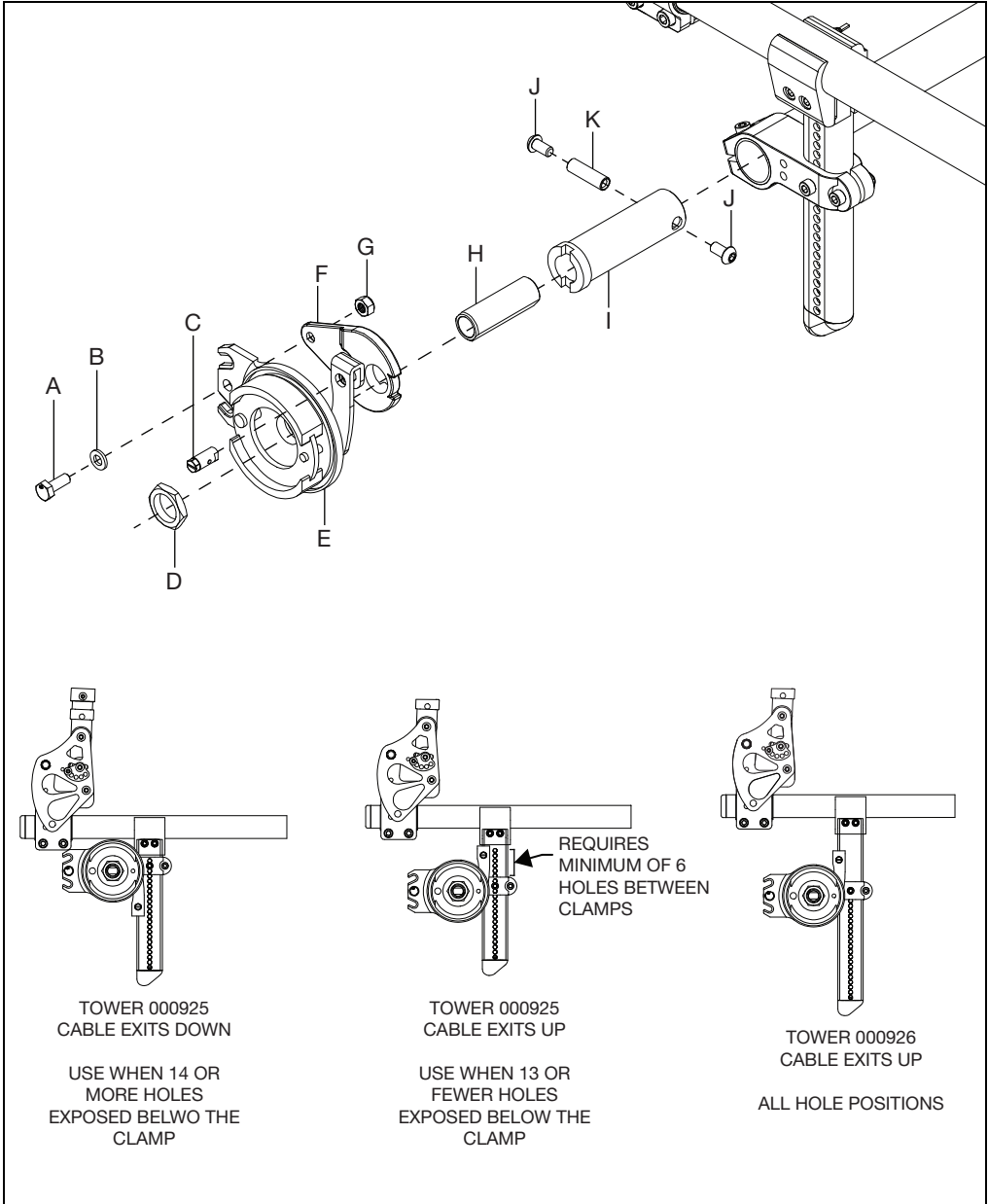

Drum Brake

3. Install the cable to the trigger lever (D) by removing the lever from the mount and removing the cable core from the cable jacket and routing it through the rearmost hole in the lever. Replace the lever and thread the core back through the cable jacket.
4. Install trigger lever (D) and extension adapter (E) to the back post handle with four screws (A & C) and threaded barrel (B).
5. Install the tube end plug (F) on the back of the extension adapter.
6. Install the push handle grip (G) onto the extension adapter.

NOTE: Cable usage based on the configuration is shown in the tables below the image.

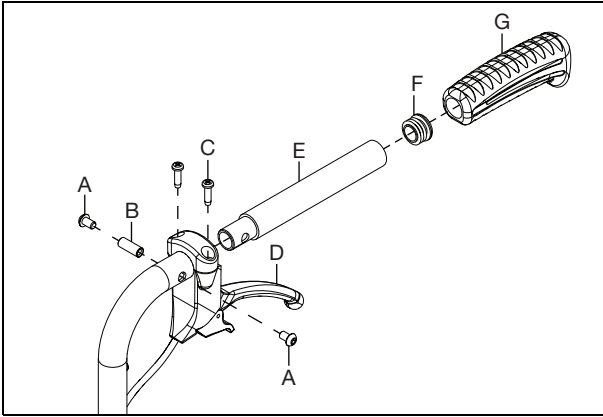

Cable Size for Backrest Type

		Fixed Height	Height Adjustable	
			Ex Short & Short	Medium & Tall
Backrest Height	9	4XS	3XS	
	10	4XS		
	11	3XS		
	12	3XS		
	13	3XS		
	14	3XS	2XS	
	15	2XS		
	16	2XS		
	17	2XS		
18	2XS			

Drum Brake

7. Route the cable down the backrest cane to the drum brake.
8. Thread the end of the the cable through the hole in the pinch bolt and tighten after removing all play from the cable.
9. Adjust cable until no wheel drag is present and positive lock is achieved with levers.
10. Secure cable to back cane and frame with cable clip (A) and P-Clip (B) as shown.

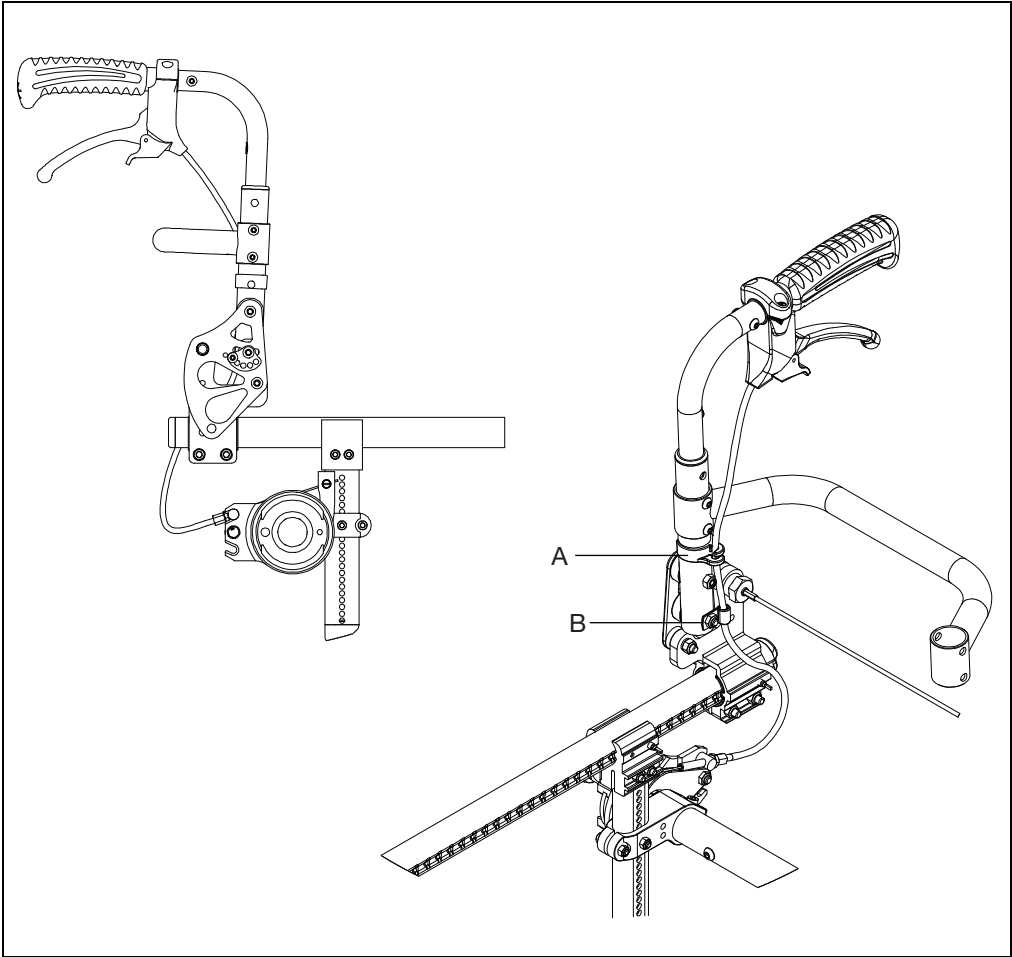

Caster Flutter

CASTER FLUTTER: Caster flutter is when the front casters start to move uncontrollably from side to side as the wheel rolls forward.

COMMON CAUSES: High speeds, misalignment of caster to ground and looseness in the caster/fork/stem assembly.

1. Check to make sure all fasteners in the caster, fork and stem assembly have been appropriately tightened down and that there is no excessive play between any of the parts. The hardware that needs to be checked is called out in the image below and the tools needed for each bolt are in the table below. Check for caster flutter. If still present, move to the next step.

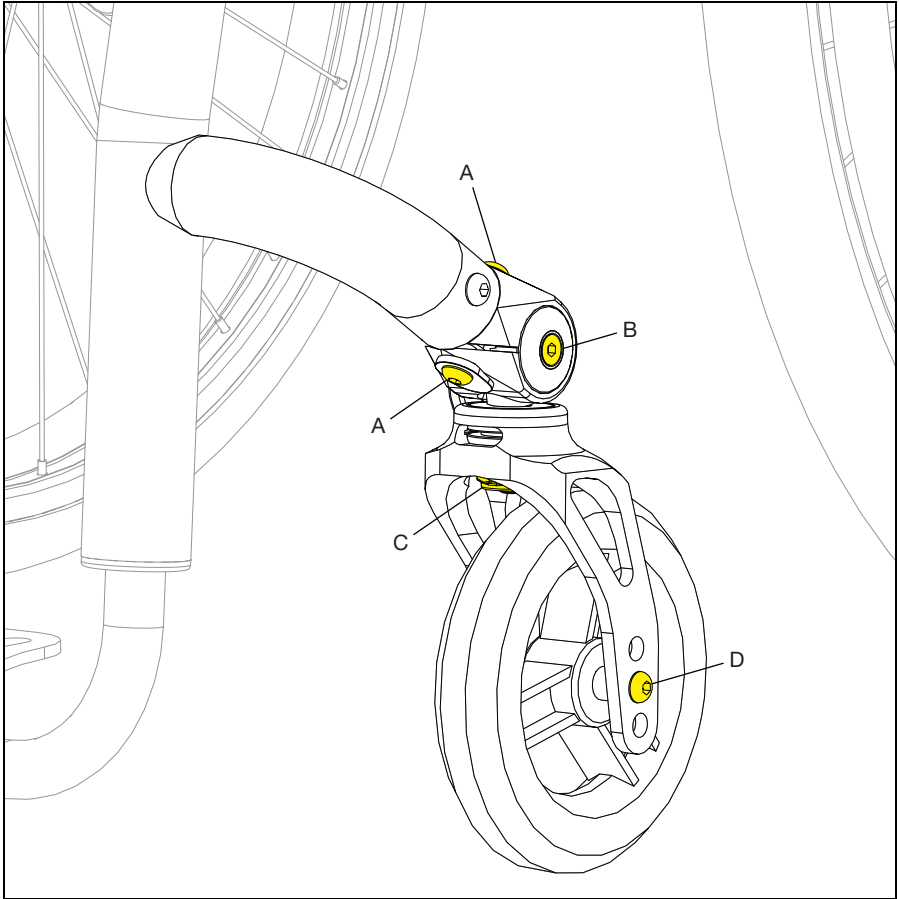

A - Two 4mm Allen wrenches needed for tightening/adjustment.	B - Two 3mm Allen wrenches needed for tightening/adjustment.	C - A 19mm or 3/4" socket wrench needed for tightening/adjustment.
D - Two 4mm Allen wrenches needed for tightening/adjustment		

Caster Flutter

2. Check to make sure casters are square and there is no caster float (caster doesn't or barely touches the ground) while seated in the chair.

Adjusting the Caster Angle:

- a. Loosen the bottom screw (A) and turn the top screw (A) of the caster housing wing. Loosening will begin to tilt the caster forward. By tightening, you will turn the caster rearward.
- b. Loosen or tighten until you align the caster stem so it is perpendicular to the floor.
- c. Place a large right triangle against the flat surface of the fork, as shown below.
- d. Test for caster flutter. If still present, continue to the next step.

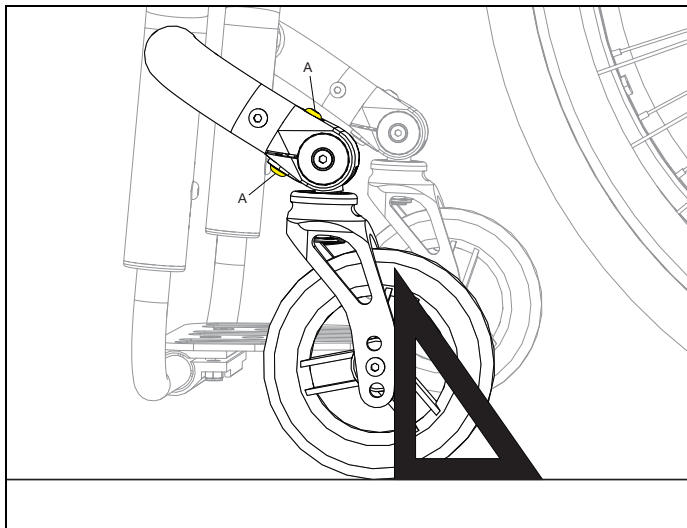

3. Open caster angle by adjusting the caster toward the front of the chair by one degree. Check for flutter. If still present, add another degree. Continue to do this until you reach three degrees. It is not recommended to open the caster angle beyond three degrees.

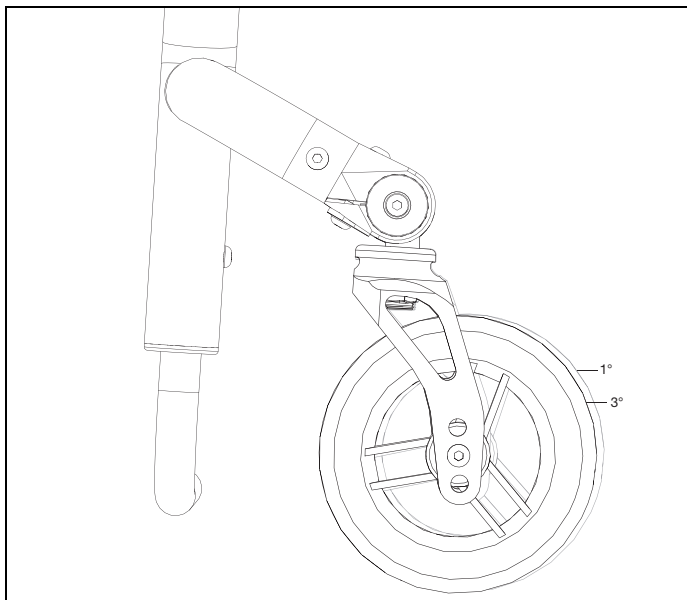



Ki Mobility
5201 Woodward Drive
Stevens Point, Wisconsin 54481
715-254-0991
www.kimobility.com



DCN0480.7