

SLING INSTRUCTION SHEET

UNIVERSAL SLING

The Universal Sling is a multipurpose sling that provides toileting access (when clothing is removed in advanced) as well as good trunk and thigh support. The Universal Sling is available in a wide variety of fabrics and can be used with a floor or ceiling lift. The sling is used to lift clients from supine or seated. This sling can be used for clients with limited upper body function and tone. This sling serves clients with varying degrees of head and neck control as it is available with or without head support.

UNIVERSAL SLING

UNIVERSAL SLING w/ TAPERED HEAD SUPPORT

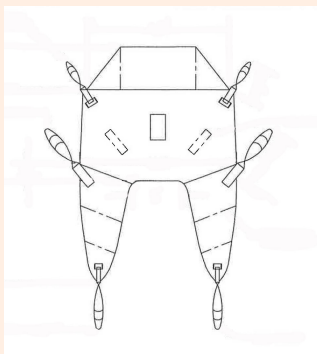
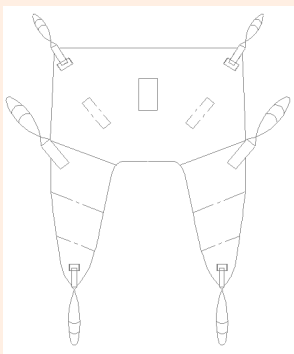

SIZE	SPACER	POLYSLIP	MESH/POLY
X-Large with tapered H/S	8A4200	8A1200	8A2200
	8A4230	8A1220	8A2230
Large with tapered H/S	8A4300	8A1300	8A2300
	8A4330	8A1320	8A2330
Medium with tapered H/S	8A4400	8A1400	8A2400
	8A4430	8A1420	8A2430
Small with tapered H/S	8A4500	8A1500	8A2500
	8A4530	8A1520	8A2530
Junior with tapered H/S	8A4600	8A1600	8A2600
	8A4630	8A1620	8A2630
Child with tapered H/S	8A4700	8A1700	8A2700
	8A4730	8A1720	8A2730

SAFE WORKING LOAD:

XXS & XS	625 lbs	450 lbs	450 lbs
S, M & L	625 lbs	625 lbs	625 lbs
XL & XXL	625 lbs	1,000 lbs	1,000 lbs

LEAVE IN PLACE

Slings should only be left in place if they are made of spacer fabric. Other fabrics will increase the risk of skin breakdown if left under the patient for long periods of time.

The decision to leave a sling in place must be based on strong clinical reasoning and the rationale should be documented. A trained professional should always perform a risk assessment to determine which sling should be used.

Always refer to your institutional policies and procedures to ensure appropriate precautions are being followed.

APPLYING THE SLING

WHEN THE CLIENT IS SITTING DOWN:

1. Ask the client to lean forward. If the client cannot do this by him/herself, gently bring him/her forward using the sling behind the shoulders to assist you.

2. Apply the sling:

- Tuck the sling down behind the client's back with the tag on the outside
- The bottom edge should fall just below the tailbone
- Let the rest of the sling slide down between the client's back and the chair back



3. Tuck the leg bands under the client's thighs and pull tightly to ensure that they are of equal length

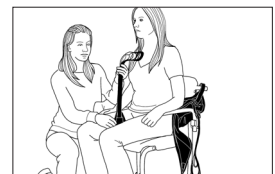

4. At the base of the leg section strap there is a loop. Bring the straps together by passing one strap through the loop



5. Bring the top of the sling in line with the client's shoulders



6. Attach the loops on the straps to the carry bar on the lift

- Make sure you use the same colour loops on both sides of the sling
- Remember: Short loops for Shoulders, and Long loops for Legs if you want the client to be lifted in an upright seated position
- Ensure loops remain securely attached to the carry bar as you lift.

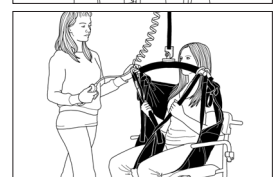

Handicare

81 Romina Drive, Concord ON L4K 4Z9 Canada | 1.877.304.5438 | www.handicare.ca
10888 Metro Court, St. Louis, MO 63043 USA | Toll Free: 1.866.891.6502 | www.handicareusa.com

SLING INSTRUCTION SHEET

UNIVERSAL SLING

WHEN THE PATIENT IS LYING DOWN:

1. Assist the client to roll onto his or her side – have him or her help as much as possible.

2. Position the sling underneath the client:

a. Fold the sling in half lengthwise with the tag on the outside

b. Place the folded edge 2 inches away from the client and then tuck the top layer under the client's back



c. Bottom edge should be at the tailbone and top edge at the shoulders

d. Ask the client to roll onto his or her back then walk around to the other side of the bed



e. Ask the client to roll away from you just enough that you can pull the tucked flap flat onto the bed

f. Ask the client to roll onto his or her back

3. Tuck the leg bands under the client's thighs and pull tightly to ensure that they are of equal length



4. At the base of the leg section strap there is a loop. Bring the straps together by passing one strap through the loop. Now raise the top of the sling level with the person's shoulders

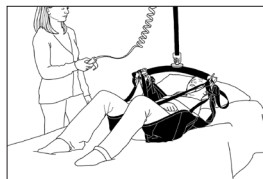

5. Bring the top of the sling in line with the client's shoulders

6. Attach the loops on the straps to the carry bar on the lift

a. Make sure you use the same colour loops on both sides of the sling

b. Remember: Short loops for Shoulders, and Long loops for Legs if you want the client to be lifted in an upright seated position

c. Ensure loops remain securely attached to the carry bar as you lift.

LIFTING FROM THE FLOOR:

Before commencing the maneuver, introduce a pillow to ensure the client is comfortable. Follow the procedures 1-2 as above to fit the sling. If using a mobile lift, introduce the lift sling using the method approved in your local area so that the carry bar is positioned correctly above the client.

LIFTING THE CLIENT

1. a. Begin lifting the client:



b. Have the client operate the hand control if possible

c. Once you have reached the point at which there is tension on the straps but the client has not yet been lifted off of the surface, STOP THE LIFT.

d. Make sure all straps are securely fastened to the carry bar and that the sling has not shifted position on the client's body (i.e., it is not slipping up the client's back and there are no folds or wrinkles in the sling fabric). If you notice anything of concern, stop the lift, and reassess the situation.

2. Transfer the client to the receiving surface

Washing Instructions

The sling should be inserted into a washing/laundry bag prior to being placed into the washer. This is to prevent any unusual wear and tear of the sling by the agitator and/or other parts of the washing machine.



Note: The Universal Sling is made from polyester & nylon materials. Life expectancy is up to 4 years depending on use, care and laundering process. Always follow general guidelines before use. Discard the sling if any tears or serious defects are found.

GENERAL GUIDELINES

Only people who have received proper training should attempt to use Handicare Lift Systems. Improper use can lead to serious injury.

Please read and adhere to the following guidelines:

1. Read all lift instructions before using.
2. Do not exceed safe weight capacity.
3. Visually inspect the sling prior to using it (check for fraying, cuts, or tears to straps and/or material).
4. A balanced fit is a safe fit: position the sling under and around the individual.
5. Do not use the lift systems for anything but their stated purpose.

All Handicare's loop-style slings are compatible with our complete range of carry bars.

To ensure anyone using Handicare's Lift Systems is properly trained, an on-going training program should be established. Contact your Handicare representative should you have further questions.

Handicare

21 Romina Drive, Concord ON L4K 4Z9 Canada | 1.877.304.5438 | www.handicare.ca
10888 Metro Court, St. Louis, MO 63043 USA | Toll Free: 1.866.891.6502 | www.handicareusa.com